

Installation, Operation and Maintenance Manual

Please read and save these instructions for future reference. Read carefully before attempting to assemble, install, operate or maintain the product described. Protect yourself and others by observing all safety information. Failure to comply with these instructions will result in voiding of the product warranty and may result in personal injury and/or property damage.

Belt Drive Mixed Flow Inline Fan

These fans are specifically designed for inline applications including exhaust, supply and return air. Performance capabilities range up to 26,000 cfm (44,174 m³/hr) and up to 3.0 in. wg (744 Pa) of static pressure. Fans are available in 11 sizes with nominal wheel diameters ranging from 12.8 to 41.1 inches (325 to 1041 mm) (9 - 33 unit sizes). Each fan shall bear a permanently affixed manufacturers engraved metal nameplate containing the model number and individual serial number.



General Safety Information

Only qualified personnel should install this fan. Personnel should have a clear understanding of these instructions and should be aware of general safety precautions. Improper installation can result in electric shock, possible injury due to coming in contact with moving parts, as well as other potential hazards. Other considerations may be required if seismic activity is present. If more information is needed, contact a licensed professional engineer before moving forward.

1. Follow all local electrical and safety codes, as well as the National Electrical Code (NEC) and the National Fire Protection Agency (NFPA), where applicable. Follow the Canadian Electric Code (CEC) in Canada.
2. The rotation of the wheel is critical. It must be free to rotate without striking or rubbing any stationary objects.
3. Motor must be securely and adequately grounded.
4. Do not spin fan wheel faster than max cataloged fan RPM. Adjustments to fan speed significantly affects motor load. If the fan RPM is changed, the motor current should be checked to make sure it is not exceeding the motor nameplate amps.
5. Do not allow the power cable to kink or come in contact with oil, grease, hot surfaces or chemicals. Replace cord immediately if damaged.
6. Verify that the power source is compatible with the equipment.
7. Never open access doors to a duct while the fan is running.

DANGER

Always disconnect, lock and tag power source before installing or servicing. Failure to disconnect power source can result in fire, shock or serious injury.

CAUTION

When servicing the fan, motor may be hot enough to cause pain or injury. Allow motor to cool before servicing.

CAUTION

Precaution should be taken in explosive atmospheres.

DANGER

Pour écarter les risques d'incendie, de choc électrique ou de blessure grave, veiller à toujours débrancher, verrouiller et étiqueter la source de courant avant l'installation ou l'entretien.

ATTENTION

Lors de toute intervention sur la soufflante, le moteur peut être suffisamment chaud pour provoquer une douleur voire une blessure. Laisser le moteur refroidir avant toute maintenance.

ATTENTION

Faire preuve de précaution dans les atmosphères explosives.

Receiving

Upon receiving the product, check to ensure all items are accounted for by referencing the delivery receipt or packing list. Inspect each crate or carton for shipping damage before accepting delivery. Alert the carrier of any damage detected. The customer will make notification of damage (or shortage of items) on the delivery receipt and all copies of the bill of lading which is countersigned by the delivering carrier. If damaged, immediately contact your Representative. Any physical damage to the unit after acceptance is not the responsibility of the manufacturer.

Unpacking

Verify that all required parts and the correct quantity of each item have been received. If any items are missing, report shortages to your local representative to arrange for obtaining missing parts. Sometimes it is not possible that all items for the unit be shipped together due to availability of transportation and truck space. Confirmation of shipment(s) must be limited to only items on the bill of lading.

Handling

Fans are to be rigged and moved by the lifting brackets provided or by the skid when a forklift is used. Location of brackets varies by model and size. Handle in such a manner as to keep from scratching or chipping the finish. Damaged finish may reduce the ability of the fan to resist corrosion.

Fans should never be lifted by the shaft, fan housing, motor, belt guard, windband or accessories.

Storage

Fans are protected against damage during shipment. If the unit cannot be installed and operated immediately, precautions need to be taken to prevent deterioration of the unit during storage. The user assumes responsibility of the fan and accessories while in storage. The manufacturer will not be responsible for damage during storage. These suggestions are provided solely as a convenience to the user.

Indoor - The ideal environment for the storage of fans and accessories is indoors, above grade, in a low humidity atmosphere which is sealed to prevent the entry of blowing dust, rain or snow. Temperatures should be evenly maintained between 30° to 110°F (-1° to 43°C) (wide temperature swings may cause condensation and “sweating” of metal parts). All accessories must be stored indoors in a clean, dry atmosphere.

Remove any accumulations of dirt, water, ice or snow and wipe dry before moving to indoor storage. To avoid “sweating” of metal parts allow cold parts to reach room temperature. To dry parts and packages use a portable electric heater to get rid of any moisture buildup. Leave coverings loose to permit air circulation and to allow for periodic inspection.

The unit should be stored at least 3½ in. (89 mm) off the floor on wooden blocks covered with moisture proof paper or polyethylene sheathing. Aisles between parts

and along all walls should be provided to permit air circulation and space for inspection.

Outdoor - Fans designed for outdoor applications may be stored outdoors, if absolutely necessary. Roads or aisles for portable cranes and hauling equipment are needed.

The fan should be placed on a level surface to prevent water from leaking into the fan. The fan should be elevated on an adequate number of wooden blocks so that it is above water and snow levels and has enough blocking to prevent it from settling into soft ground. Locate parts far enough apart to permit air circulation, sunlight and space for periodic inspection. To minimize water accumulation, place all fan parts on blocking supports so that rain water will run off.

Do not cover parts with plastic film or tarps as these cause condensation of moisture from the air passing through heating and cooling cycles.

Fan wheels should be blocked to prevent spinning caused by strong winds.

Inspection/Maintenance During Storage

While in storage, inspect fans once per month. Keep a record of inspection and maintenance performed.

If moisture or dirt accumulations are found on parts, the source should be located and eliminated. At each inspection, rotate the wheel by hand ten to fifteen revolutions to distribute lubricant on motor. If paint deterioration begins, consideration should be given to touch-up or repainting. Fans with special coatings may require special techniques for touch-up or repair.

Machined parts coated with rust preventive should be restored to good condition promptly if signs of rust occur. Immediately remove the original rust preventive coating with petroleum solvent and clean with lint-free cloths. Polish any remaining rust from surface with crocus cloth or fine emery paper and oil. Do not destroy the continuity of the surfaces. Thoroughly wipe clean with Tectyl® 506 (Ashland Inc.) or the equivalent. For hard to reach internal surfaces or for occasional use, consider using Tectyl® 511M Rust Preventive, WD-40® or the equivalent.

Removing from Storage

As fans are removed from storage to be installed in their final location, they should be protected and maintained in a similar fashion until the fan equipment goes into operation.

Prior to fully assembling and installing the fan and system components, inspect the fan assembly to make sure it is in working order.

1. Check fasteners, set screws, wheel, bearings, drive, motor base and accessories for tightness.
2. Rotate the fan wheel by hand and assure no parts are rubbing. Access to the wheel is obtained through the inlet of the fan.
3. Ensure proper wheel settings for radial gap and alignment. See Fig. 10 on page 4.

Mounting Configurations

Horizontal Hanging or Base Mount

With a hanging mount, the motor may be located on either the top or bottom of the housing. Base mounting allows the motor to be located on top only. In these configurations, standard mounting supports are provided.

Refer to Table 1 for dimensions.

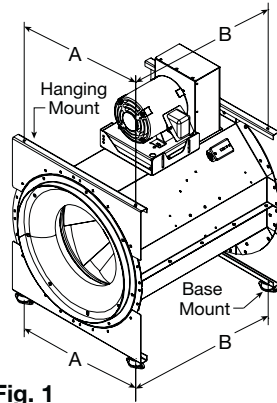

Fig. 1

Horizontal Hanging or Base Mount

The motor may be located on either side of the housing with a horizontal hanging or base mount. In these configurations, extended mounting supports are provided.

Refer to Table 1 for dimensions.

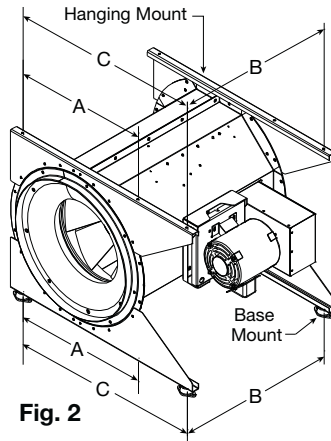

Fig. 2

TABLE 1

Model Size	A	B	C
9	15 ³ / ₈ (391)	20 ¹ / ₂ (521)	20 ³ / ₈ (518)
12	18 ⁵ / ₈ (467)	25 ¹ / ₂ (638)	27 ¹ / ₄ (705)
15	22 ¹ / ₈ (562)	27 ⁵ / ₈ (702)	33 ¹ / ₂ (851)
16	24 ¹ / ₄ (616)	29 ⁵ / ₈ (752)	35 ¹ / ₂ (902)
18	26 ⁵ / ₈ (676)	31 ⁵ / ₈ (803)	38 (965)
20	28 ⁷ / ₈ (733)	34 ¹ / ₈ (867)	40 (1016)
22	31 ³ / ₄ (806)	37 ⁵ / ₈ (956)	44 ¹ / ₂ (1130)
24	36 (914)	41 ¹ / ₈ (1045)	47 ¹ / ₄ (1200)
27	38 ¹ / ₂ (978)	43 ³ / ₈ (1108)	52 (1321)
30	44 ¹ / ₂ (1130)	50 ⁵ / ₈ (1286)	58 ⁷ / ₈ (1495)
33	48 ¹ / ₂ (1232)	55 ¹ / ₈ (1400)	62 ⁷ / ₈ (1597)

All dimensions in inches (millimeters).

Vertical Mount

With a vertical mount, the unit can either be hung from above, or mounted to the floor. The motor will always be mounted on the side of the unit between the mounting supports.

Refer to Table 2 for dimensions.

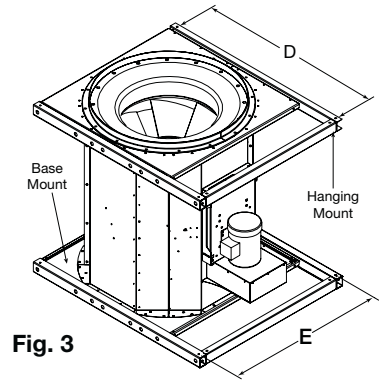

Fig. 3

TABLE 2

Model Size	D	E
9	24 ³ / ₄ (629)	23 (584)
12	27 ³ / ₄ (705)	26 (659)
15	33 ¹ / ₂ (850)	29 ⁵ / ₈ (752)
16	37 ¹ / ₂ (952)	31 ¹ / ₄ (805)
18	38 (965)	33 ³ / ₈ (860)
20	44 ¹ / ₈ (1121)	38 ³ / ₈ (974)
22	44 ⁷ / ₈ (1140)	39 ⁵ / ₈ (1006)
24	48 (1219)	42 ¹ / ₄ (1072)
27	52 (1320)	46 ⁵ / ₈ (1172)
30	58 ⁷ / ₈ (1496)	50 ⁵ / ₈ (1291)
33	61 (1549)	55 ¹ / ₈ (1402)

All dimensions in inches (millimeters).

Installation

Installations with poor inlet or discharge configurations may result in reduced fan performance. See Fig. 4 thru 7.

Ducted Installations

Inlet Duct Turns – Installation of a transition or duct turn too close to the fan inlet reduces fan performance. Restricted or unstable flow at the fan inlet can cause pre-rotation of incoming air or uneven loading of the fan wheel, yielding large system losses and increased sound levels. To achieve full fan performance, there should be at least one equivalent duct diameter between the transition or duct turn and the fan inlet.

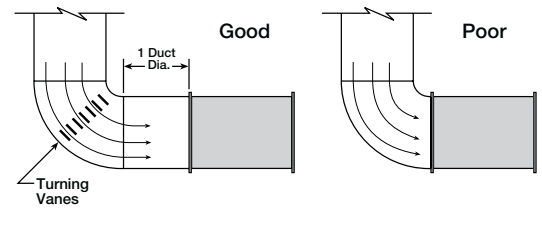
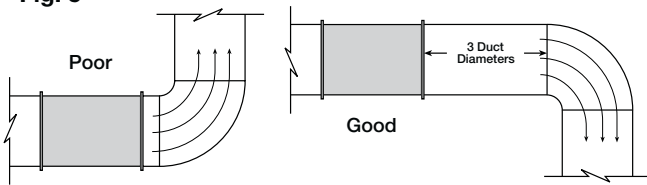

Fig. 4

Discharge Duct Turns – Fan performance is reduced when transitions or duct turns are made immediately after the fan discharge. To achieve cataloged fan performance there should be at least three equivalent duct diameters of straight ductwork between the fan discharge and any duct turns or transitions.

Fig. 5



Non-Ducted Installation

Inlet Clearance – Installation of a fan with an open inlet too close to a wall or bulkhead will cause reduced fan performance. It is desirable to have a minimum of one equivalent duct diameter between the fan inlet and the wall.

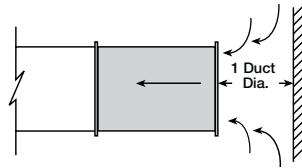

Fig. 6

Free Discharge – Free or abrupt discharge into a plenum results in a reduction in fan performance.

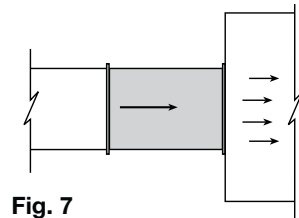

Fig. 7

Duct Connections

It is highly recommended to use a flexible sleeve connection instead of a rigid duct connection. This will reduce vibration transmission through the ductwork.

Slip-Fit End Connection - Removable duct collars are bolted to the fan to provide a slip-fit connection for a flexible sleeve.

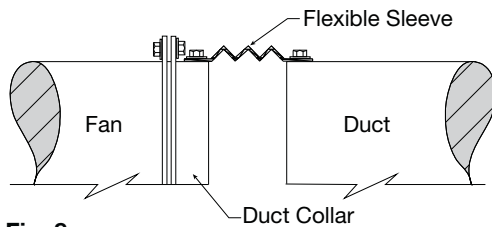

Fig. 8

Flanged End Connection – Remove standard duct collars to allow for flanged end connection. Directly bolt inlet and outlet flanges to ductwork. No additional parts are required.

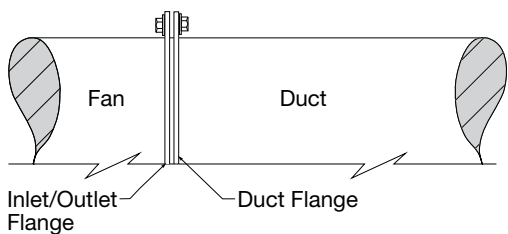

Fig. 9

Pre-Start-up Checks

1. Disconnect and lock-out all power switches to fan.
2. Check all fasteners, set screws and locking collars on the fan, wheel, bearings, drive, motor base and accessories for tightness.
3. Rotate the fan wheel by hand and assure no parts are rubbing. The wheel should rotate freely and be aligned as shown in Fig. 10. Wheel position is preset and the unit is tested at the factory. Movement may occur during shipment, and realignment may be necessary. Nominal Gap dimension is equal to 1/8 inch.

Radial Gap* - Adjust inlet cone position such that the radial gap between the wheel cone and inlet cone is evenly distributed around the wheel.

Alignment* - If necessary, adjust wheel position by loosening the wheel hub from the fan shaft so that a straight edge held tight to the wheel cone just touches the inlet cone. Refer to Fig. 10.

***Note these functions must take place prior to installation.**

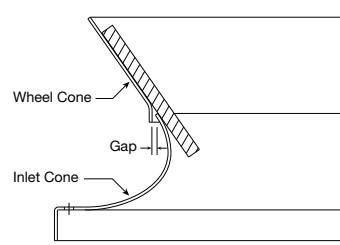

Fig. 10

4. Check for bearing alignment and lubrication.
5. Check the pulleys for proper alignment. Misaligned pulleys lead to excessive belt wear, vibration, noise, and power loss. (See Fig. 11).

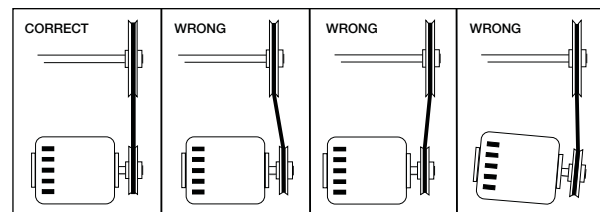

Fig. 11

6. The adjustable motor pulley is factory set for the RPM specified. Speed can be increased by closing or decreased by opening the adjustable motor sheave. Two groove variable pitch pulleys must be adjusted an equal number of turns open or closed. Any increase in speed represents a substantial increase in the horsepower required by a unit. Motor amperage should always be checked to avoid serious damage to the motor when speed is varied.

7. Check belt tension. Belt tension can be adjusted by loosening two fasteners marked “A” in Fig. 12 below. The motor plate can then be adjusted up or down using the two adjustment bolts marked “B” in Fig. 12. Ensure that both adjustment bolts are altered by the same number of turns. Belt tension should be adjusted to allow 1/64 inch of deflection per inch of belt span. For example, a 15 inch belt span should have 15/64 inch (or about 1/4 inch) of deflection with moderate thumb pressure at the mid-point between pulleys (see Fig. 13). Overtightening will cause excessive wear and noise. Too little tension will cause slippage at start-up and uneven wear. Retighten “A” once tension is correct.

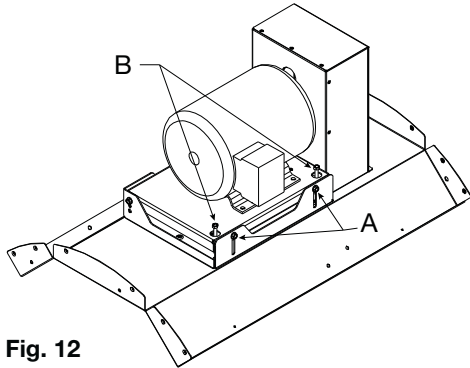

Fig. 12

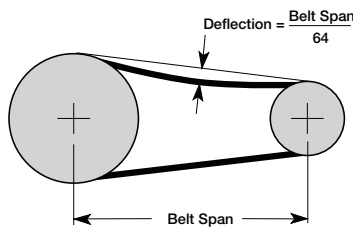
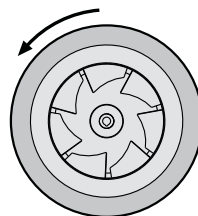

Fig. 13

8. Check all guarding (if supplied) to ensure it's securely attached and not interfering with rotating parts.
9. Check all electrical connections for proper attachment.
10. Check housing and ductwork, if accessible, for obstructions and foreign material that may damage the fan wheel.
11. **Wheel Rotation:** Direction of wheel rotation is critical. Reversed rotation will result in poor air performance, motor overloading and possible burnout. Check wheel rotation by momentarily energizing the unit. Rotation should be counterclockwise when viewed from the fan inlet and correspond to the rotation decal on the unit.



Mixed Flow
Fig. 14

NOTE

One of the most frequently encountered problems with mixed flow fans is motors wired to run in the wrong direction. This is especially true with 3-phase installations where the motor will run in either direction, depending on how it has been wired. To reverse rotation of a 3-phase motor, interchange any two of the three electrical leads. Single phase motors can be reversed by changing internal connections as described on the motor label or wiring diagram.

DANGER

High voltage electrical input is needed for this equipment. This work should be performed by a qualified electrician.

DANGER

Cet appareil nécessite une alimentation électrique sous haute tension. Confier ce travail à un électricien qualifié.

DANGER

Disconnect and secure to the 'OFF' position all electrical power to the fan prior to inspection or servicing. Failure to comply with this safety precaution could result in serious injury or death.

DANGER

Pour écarter les risques de blessure grave ou de mort, débrancher et verrouiller l'alimentation électrique en position « Arrêt » avant tout contrôle ou entretien.

Operation

Before starting up or operating fan, check all fasteners for tightness. In particular, check the setscrews in wheel hub and pulleys.

1. While in the 'OFF' position or before connecting the fan to power, turn the fan wheel by hand to be sure it is not striking the venturi or any obstacle.
2. Start the fan and shut it off immediately to check rotation of the wheel with directional arrow in the motor compartment, see Fig. 14.
3. Fans with multi-speed motors should be checked on low speed during initial start-up.
4. When the fan is started, observe the operation and check for any unusual noise, vibration or overheating of bearings. Refer to the Troubleshooting section of this manual if a problem develops.
5. Grease may be forced out of the bearing seals during initial start-up. This is a normal self-purging feature of the bearing.
6. With the system in full operation and all ductwork attached, measure current input to the motor and compare with the nameplate rating to determine if the motor is operating under safe load conditions.
7. Keep inlets and approaches to fan clean and free from obstruction.

Vibration

Excessive vibration is the most frequent problem experienced during initial start-up. Left unchecked, excessive vibration can cause a multitude of problems, including structural and/or component failure.

The most common sources of vibration are:

- Wheel imbalance
- Drive pulley misalignment
- Incorrect belt tension
- Bearing misalignment
- Mechanical looseness
- Faulty belts
- Drive component unbalance
- Poor inlet/outlet conditions
- Foundation stiffness

Many of these conditions can be discovered by careful observation. Refer to the Troubleshooting section of this manual for corrective actions.

If observation cannot locate the source of vibration, a qualified technician using vibration analysis equipment should be consulted. If the problem is wheel imbalance, in place balancing can be done providing there is access to the fan wheel. Any correction weights added to the wheel should be fastened to either the wheel back (single-plane balance) or to the wheel back and wheel cone (two-plane balance).

DANGER

Disconnect and secure to the 'OFF' position all electrical power to the fan prior to inspection or servicing. Failure to comply with this safety precaution could result in serious injury or death.

DANGER

Pour écarter les risques de blessure grave ou de mort, débrancher et verrouiller l'alimentation électrique en position « Arrêt » avant tout contrôle ou entretien.

Inspection

Inspection of the fan should be conducted at the first 30 minute and 24 hour intervals of satisfactory operation.

30 Minute Interval - Inspect bolts, set screws and motor mounting bolts. Adjust and tighten as necessary.

24 Hour Interval - Check all internal components. Inspect belt alignment and tension. Adjust and tighten as necessary.

Maintenance

Installation and maintenance are to be performed only by qualified personnel who are familiar with local codes and regulations, and who are experienced with this type of equipment.

IMPORTANT

Some maintenance procedures will require the fan to be removed from the duct system. Ensure there is enough space around the fan to perform this operation and that proper lifting equipment is used.

IMPORTANT

Do not allow water or solvents to enter the motor or bearings. Under no circumstances should motors or bearings be sprayed with steam, water or solvents.

Motor maintenance is generally limited to cleaning and lubrication (where applicable). Limit cleaning to exterior surfaces only. Removing dust buildup on motor housing ensures proper motor cooling.

Greasing of motors is only intended when fittings are provided. Many fractional horsepower motors are permanently lubricated and should not be lubricated after installation. Motors supplied with grease fittings should be greased in accordance with manufacturers' recommendations. Where motor temperatures do not exceed 104°F (40°C), the grease should be replaced after 2,000 hours of running time as a general rule.

Wheels require little attention when moving clean air. Occasionally, oil and dust may accumulate causing imbalance. When this occurs clean the wheel and housing to ensure smooth and safe operation.

Prior to restarting unit, check all fasteners for tightness each time maintenance checks are performed.

A proper maintenance program will help deliver years of dependable service. Once the unit has been put into operation, a routine maintenance schedule should be set up to accomplish the following:

1. Lubrication of bearings and motor.
2. Belts should be checked for wear and tightness.
3. Wheel, housing, bolts and set screws on the entire fan should be checked for tightness.
4. Any dirt accumulation on the wheel or in the housing should be removed to prevent imbalance and possible damage.
5. Spring isolators should be checked for breaks and fatigue. Check rubber isolators for deterioration.
6. Inspect fan impeller and housing looking for fatigue, corrosion or wear.

IMPORTANT

Changing the belts or drives can significantly increase the amp draw of the motor. If changes are made to the drives or belts, the amps must be checked to assure no overamping.

Belt/Drive Sheave Maintenance

Belts and drive sheaves must be checked on a regular basis for wear, tension, alignment and dirt accumulation. Premature or frequent belt failures can be caused by improper belt tension (either too loose or too tight) or misaligned sheaves. Abnormally high belt tension

or drive misalignment will cause excessive bearing loads and may result in failure of the fan and/or motor bearings. Conversely, loose belts will cause squealing on start-up, excessive belt flutter, slippage and overheated sheaves. Either excessively loose or tight belts may cause fan vibration.

1. Belts tend to stretch after a period of time. They should be checked periodically for wear and tightness. When replacing belts, use the same type as supplied with the unit.
2. Matched belts should always be used on units with multi-groove pulleys.
3. For belt replacement, loosen the tensioning device enough to allow removal of the belt by hand. Do not force belts on or off. This may cause cords to break, leading to premature belt failure. Do not install new belts on worn sheaves. If the sheaves have grooves worn in them, they must be replaced before new belts are installed.
4. Once installed, adjust belts as shown in “Pre-Start-up Checks”.

Drive Sheave Replacement

Drive components supplied by the manufacturer, have been carefully selected for this unit’s specific operating condition. Changing drive components could result in unsafe operating conditions which may cause personal injury or failure of fan components.

1. Remove the protective coating from end of the fan and motor shafts using mineral spirits or another similar solvent. Check to ensure that the shaft is free of nicks and burrs. Remove old sheaves.
2. Slide sheaves on shafts. Do not drive sheaves on as this may result in bearing damage.
3. Align fan and motor sheaves with a straight-edge or string and tighten.
4. Place belts over sheaves. Do not pry or force belts, as this could damage the cords in the belts.
5. Adjust the tension until the belts appear snug. Run the unit for a few minutes (refer to unit start-up section) and allow the belts to “set” properly.
6. With the fan off, adjust the belt tension by moving the motor plate; belts are adjusted by raising or lowering the motor plate. When in operation, the tight side of the belts should be in a straight line from sheave to sheave with a slight bow on the slack side.

Bearing Maintenance

The bearings for these fans are carefully selected to match the maximum load and operating conditions of the specific class, arrangement and fan size. The instructions provided in this manual and those provided by the bearing manufacturer will minimize any bearing problems. Bearings are the most critical moving part of the fan. Therefore, special care is required when mounting them on the unit and maintaining them.

Refer to Tables 3 and 4 below and the manufacturer’s instructions for grease types and intervals for various

operating conditions. Never mix greases made with different bases. This will cause a breakdown of the grease and possible failure of the bearing.

TABLE 3

Recommended Fan Bearing Lubrication Schedule (in Months)							
Fan RPM	Bearing Bore - Dimensions in inches (mm)						
	1/2 - 1	1 1/8 - 1 1/2	1 5/8 - 1 7/8	1 15/16 - 2 1/16	2 7/16 - 3	3 3/16 - 3 1/2	3 15/16 - 4 1/2
	(13-25)	(29-38)	(41-48)	(49-56)	(62-76)	(81-89)	(100-114)
To 250	6	6	6	6	6	5	4
500	6	6	6	5	4	3	3
750	6	5	4	3	3	2	2
1000	6	4	3	2	2	1	1
1250	5	3	2	1	1	0.5	0.5
1500	5	2	1	1	0.5	0.5	0.25
2000	5	1	1	0.5	0.25	0.25	0.25
2500	4	0.5	0.5	0.25	0.25	0.25	
3000	4	0.5	0.25	0.25	0.25		

NOTE: Suggested initial greasing interval is based on 12 hour per day operation and 150° F. (66°C) maximum housing temperature. For continuous (24 hour) operation, decrease greasing interval by 50%. If unusual environment conditions exist (extreme temperature, moisture or contaminants) more frequent lubrication is required.

1. If possible, relubricate with grease while in operation without endangering personnel.
2. Ball bearings (operating): Relubricate until clean grease is seen purging at the seals. Be careful not to unseat the seal by over lubricating.
3. Ball bearings (idle): Add one to two shots of grease up to 2 inch (51 mm) bore sizes, and four to five shots of grease above 2 inch (51 mm) bore sizes with hand grease gun.
4. Adjust lubrication frequency based on condition of purged grease.
5. A high quality lithium base grease conforming to NLGI Grade 2 consistency, such as those listed in Table 4, should be used.

IMPORTANT

Lubricate bearings prior to periods of extended shutdowns or storage and rotate shaft monthly to aid in preventing corrosion. If the fan is stored more than three months, the bearings should be purged with new grease prior to start-up.

TABLE 4

Grease Manufacturers	
Mobil Oil Corporation	Mobilith SHC 220
	Mobilith AW2
Shell	Alvania #2
Texaco, Inc.	Multifak AFB2
	Premium RB
Exxon	Unirex N2

Bearing Replacement

Replacement of bearings requires disassembly of internal components. For this procedure access must be available to both the inlet and outlet ends. The following procedure assumes belts have already been loosened and removed. (Belts are removed by adjusting the motor plate).

Reinstall components in reverse order of removal. Reference the Radial Gap and Alignment sections on page 4 to ensure proper wheel installation.

If the bearings cannot be removed from the shaft due to corrosion or damage, the bearings and shaft can be removed as a complete assembly from the fan outlet.

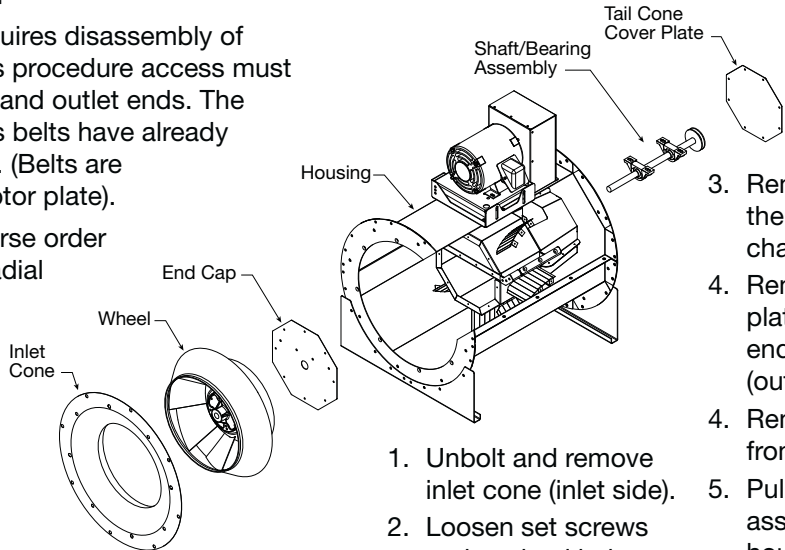

1. Unbolt and remove inlet cone (inlet side).
2. Loosen set screws at the wheel hub and remove wheel (inlet side).
3. Remove end cap from the end of the inner chamber (inlet side).
4. Remove tail cone cover plate from the opposite end of the inner chamber (outlet side).
4. Remove bearing bolts from mounting plate.
5. Pull shaft/bearing assembly out of the fan housing (outlet side).
6. Replace bearings on shaft/bearing assembly.

Troubleshooting

WARNING

Before taking any corrective action, make certain unit is not capable of operation during repairs.

AVERTISSEMENT

Avant d'entreprendre toute action corrective, s'assurer que l'appareil ne pourra pas fonctionner durant les réparations.

Problem	Cause	Corrective Action
Excessive noise or vibration	Wheel imbalance	Clean all dirt off wheel. Check wheel balance, rebalance in place if necessary.
	Bad bearings	Replace with equivalent bearings.
	Belts too tight or too loose	Adjust tension, see Fig. 13 on page 5.
	Wheel improperly aligned and rubbing	Center wheel on inlet, see Fig. 10 on page 4.
	Loose drive or motor sheaves	Align and tighten. See "Pre-Start-Up Checks", page 4-5.
	Foreign objects in wheel or housing	Remove objects, check for damage or imbalance.
Reduced airflow	System resistance too high	Check system: proper operation of backdraft or control dampers, obstruction in ductwork, clean dirty filters.
	Unit running backwards	Correct as described in NOTE on page 5.
	Excessive dirt buildup on wheel	Clean wheel.
	Improper wheel alignment	Center wheel on inlet, see "Pre-Start-up Checks" and Fig. 10 on page 4.

Our Commitment

As a result of our commitment to continuous improvement, Venco reserves the right to change specifications without notice.

