

Installation, Operation and Maintenance Manual

Please read and save these instructions for future reference. Read carefully before attempting to assemble, install, operate or maintain the product described. Protect yourself and others by observing all safety information. Failure to comply with these instructions will result in voiding of the product warranty and may result in personal injury and/or property damage.

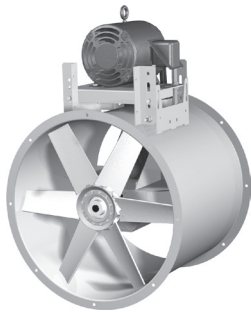

VTIC
 Level 3, 4 and 5
 Cast Aluminum Propeller



VTIF
 Level 3, 4 and 5
 Fabricated Steel Propeller

General Safety Information

Only qualified personnel should install this unit. Personnel should have a clear understanding of these instructions and should be aware of general safety precautions. Improper installation can result in electric shock, possible injury due to coming in contact with moving parts, as well as other potential hazards. Other considerations may be required if high winds or seismic activity are present. If more information is needed, contact a licensed professional engineer before moving forward.

1. Follow all local electrical and safety codes, as well as the National Electrical Code (NEC), the National Fire Protection Agency (NFPA), where applicable. Follow the Canadian Electric Code (CEC) in Canada.
2. The rotation of the propeller is critical. It must be free to rotate without striking or rubbing any stationary objects.
3. Motor must be securely and adequately grounded.
4. Do not spin fan propeller faster than the maximum cataloged fan rpm. Adjustments to fan speed with Variable Frequency Drives (VFD) may affect motor load. If the fan RPM is changed, the motor current should be checked to make sure it is not exceeding the motor nameplate amps.
5. Do not allow the power cable to kink or come in contact with oil, grease, hot surfaces or chemicals. Replace cord immediately if damaged.
6. Verify that the power source is compatible with the equipment.

DANGER

Always disconnect, lock and tag power source before installing or servicing. Failure to disconnect power source can result in fire, shock or serious injury.

CAUTION

When servicing the fan, motor may be hot enough to cause pain or injury. Allow motor to cool before servicing.

CAUTION

Precaution should be taken in explosive atmospheres.

DANGER

Pour écarter les risques d'incendie, de choc électrique ou de blessure grave, veiller à toujours débrancher, verrouiller et étiqueter la source de courant avant l'installation ou l'entretien.

ATTENTION

Lors de toute intervention sur la soufflante, le moteur peut être suffisamment chaud pour provoquer une douleur voire une blessure. Laisser le moteur refroidir avant toute maintenance.

ATTENTION

Faire preuve de précaution dans les atmosphères explosives.

Receiving

Upon receiving the product, check the bill of lading to ensure all items were received. Inspect each crate for shipping damage before accepting delivery. Notify the carrier if any damage is noticed. The carrier will make notification on the delivery receipt acknowledging any damage to the product. All damage should be noted on all the copies of the bill of lading which is countersigned by the delivering carrier. A Carrier Inspection Report should be filled out by the carrier upon arrival. If damaged upon arrival, file claim with carrier. Any physical damage to the unit after acceptance is not the responsibility of Venco Products.

Unpacking

Verify that all required parts and the correct quantity of each item have been received. If any items are missing, report shortages to your local representative to arrange for obtaining missing parts. Sometimes it is not possible that all items for the unit be shipped together due to availability of transportation and truck space. Confirmation of shipment(s) must be limited to only items on the bill of lading.

Handling

Handle in such a manner as to keep from scratching or chipping the coating. Fans should not be lifted by the motor shaft, motor housing or fan accessories. Damaged finish may reduce ability of unit to resist corrosion.

Storage

Units are protected against damage during shipment. If the unit cannot be installed and operated immediately, precautions need to be taken to prevent deterioration of the unit during storage. The user assumes responsibility of the unit and accessories while in storage. The manufacturer will not be responsible for damage during storage. These suggestions are provided solely as a convenience to the user.

INDOOR — The ideal environment for the storage of units and accessories is indoors, above grade, in a low humidity atmosphere which is sealed to prevent the entry of blowing dust, rain, or snow. Temperatures should be evenly maintained between 30°F (-1°C) and 110°F (43°C) (wide temperature swings may cause condensation and “sweating” of metal parts). All accessories must be stored indoors in a clean, dry atmosphere.

Remove any accumulations of dirt, water, ice, or snow and wipe dry before moving to indoor storage. To avoid “sweating” of metal parts allow cold parts to reach room temperature. To dry parts and packages, use a portable electric heater. Leave coverings loose to permit air circulation and to allow for periodic inspection.

The unit should be stored at least 3½ inches (89 mm) off the floor on wooden blocks covered with moisture proof paper or polyethylene sheathing. Aisles between parts and along all walls should be provided to permit air circulation and space for inspection.

OUTDOOR — Units designed for outdoor applications may be stored outdoors, if absolutely necessary. Roads or aisles for portable cranes and hauling equipment are needed.

The fan should be placed on a level surface to prevent water from leaking into the unit. The unit should be elevated on an adequate number of wooden blocks so that it is above water and snow levels and has enough blocking to prevent it from settling into soft ground. Locate parts far enough apart to permit air circulation, sunlight, and space for periodic inspection. To minimize water accumulation, place all unit parts on blocking supports so that rain water will run off.

Do not cover parts with plastic film or tarps as these cause condensation of moisture from the air passing through heating and cooling cycles.

Inspection and Maintenance during Storage

While in storage, inspect fans once per month. Keep a record of inspection and maintenance performed.

If moisture or dirt accumulations are found on parts, the source should be located and eliminated. At each inspection, rotate the fan propeller by hand ten to fifteen revolutions to distribute lubricant on motor. If paint deterioration begins, consideration should be given to touch-up or repainting. Fans with special coatings may require special techniques for touch-up or repair.

Machined parts coated with rust preventive should be restored to good condition promptly if signs of rust occur. Immediately remove the original rust preventive coating with petroleum solvent and clean with lint-free cloths. Polish any remaining rust from surface with crocus cloth or fine emery paper and oil. Do not destroy the continuity of the surfaces. Wipe thoroughly clean with Tectyl® 506 (Ashland Inc.) or the equivalent. For hard to reach internal surfaces or for occasional use, consider using Tectyl® 511M Rust Preventive or WD-40® or the equivalent.

REMOVING FROM STORAGE — As units are removed from storage to be installed in their final location, they should be protected and maintained in a similar fashion, until the equipment goes into operation.

Prior to installing the unit and system components, inspect the unit assembly to make sure it is in working order.

1. Check all fasteners on the fan, propeller, motor base, and accessories for tightness.
2. Rotate the fan propeller by hand and assure no parts are rubbing.
3. Fans should not be lifted by the motor shaft, motor housing or fan accessories.

Lifting

Fans should not be lifted by the motor, motor shaft, motor cover, belt guard, tie down points, belt tube, damper frame, windband, or fan accessories.

Flanged Housing Only

Use a minimum of four bolt holes, two per flange, or attach two suitable chains / straps around the entire fan housing, one near each duct flange when lifting large horizontal fans. Secure the fan housing to prevent the weight of a top or side mounted motor from rotating the housing while being lifted.

For vertical hanging installations, attach a suitable lifting device to the fan housing or inlet/outlet flange.

With Mounting Brackets

Fans are to be rigged by either the optional brackets provided or by the skid when a forklift is used. Slings can be attached as described above or to mounting brackets located at the ends of the fan housing.

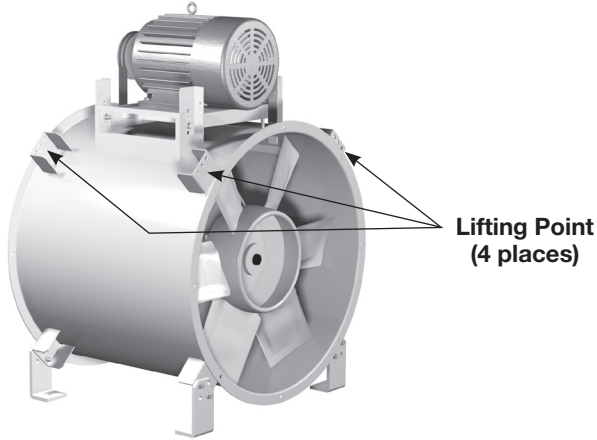

Effects of Installation on Performance

Any installation with inlet or discharge configurations that deviate from these recommendations may result in reduced fan performance. Restricted or unstable flow at the fan inlet can cause pre-rotation of incoming air or uneven loading of the fan propeller yielding large system losses and increased sound levels. Free discharge or turbulent flow in the discharge ductwork will also result in system effect losses.

The most common inlet and discharge conditions which affect fan performance are:

Inlet Duct Turns

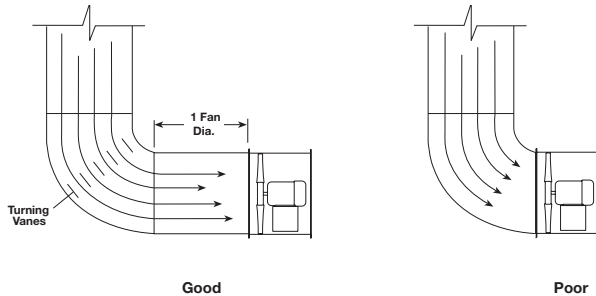

Installation of a duct turn or elbow too close to the fan inlet reduces fan performance because air is loaded unevenly into the fan prop. To achieve full fan performance there should be at least one to two fan diameters between the turn or elbow and the fan inlet.

Discharge Duct Turns

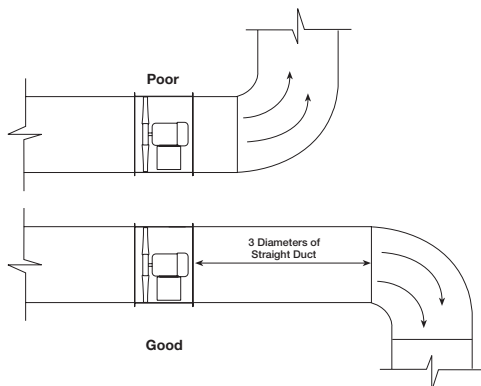

Fan performance is reduced when duct turns are made immediately off the fan discharge. To achieve cataloged fan performance, there should be at least three equivalent fan diameters of straight ductwork between the fan discharge and any duct turns.

NOTE

For curb mounted exhaust or supply systems using “Bottom Inlet” duct connections, installation of drain locations within the ductwork is recommended to allow for safe removal of any water that enters the duct system. This requires the installing contractor to determine whether insulation, watertight construction, or sloped and drained ductwork are required. For curb mounted exhaust or supply systems with “Free Inlet Bottom Intake” connections (free air inlet conditions), it is recommended to install a moisture collection drip pan at least one housing diameter below the inlet of the fan.

Typical Installations

NOTE

For units supplied or used with a Variable Frequency Drive (VFD), reference the VFD documentation for installation requirements, start-up settings, parameter adjustments and trouble shooting. VFDs provided by the factory are factory programmed for basic motor parameters, incoming voltage parameters and maximum operating speed (Hz).

Follow NEC and local codes for VFD wiring and installation. If the wire length between the VFD and the controlled motor exceeds 100 ft (30.5 m), DV/DT filters or VFD cabling may be required. Calculations and proper application of DV/DT filters and VFD cabling is by others; failing to do so may result in premature motor failure.

With Mounting Brackets

Following are typical mounting installations for models with mounting brackets. Diagrams show dimensions for ceiling hung installations. The dimensions for floor or base mount installations are mirror images of these.

For VTIF and VTIC models with motor in the 3 or 9 o'clock position or vertical installations, additional mounting rails are recommended. Mounting rail dimensions are shown for field fabrication.

Horizontal

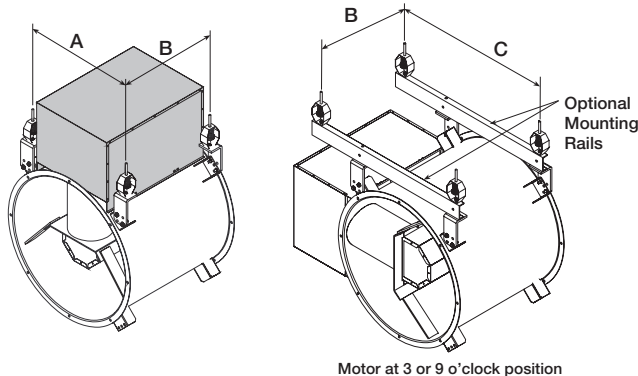

Vertical

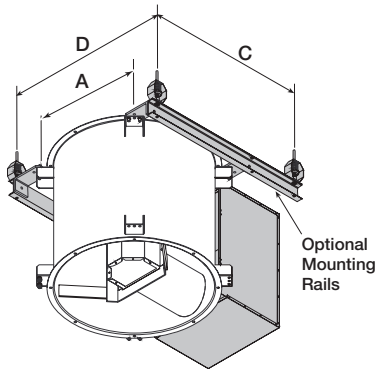

Fan Size	A	B		C	D
		Level 3	Level 4/5		
18	17.63	17.38	21.38	26.00	28.00
20	19.00	17.38	22.38	28.50	29.25
24	21.88	18.38	23.38	33.00	33.75
30	26.13	19.38	28.38	37.00	38.75
36	30.50	21.88	26.88	44.00	47.00
42	34.75	22.88	31.88	50.00	51.25
48	42.00	25.38	36.38	56.00	61.00
54	46.75	29.88	40.38	62.00	65.50
60	51.00	32.38	41.38	71.00	70.00

Dimensions shown are in inches.

To determine unit level, refer to the fan nameplate.
Example VTIC-3L42 (level 3) or VTIC-4H30 (level 4)

Continuous Duty and Emergency Exhaust

VTIF with optional high temperature construction are factory-modified for operation in high temperature continuous duty applications. With propeller on the discharge end of the fan, negative pressure is created in the belt tube during operation. Ambient air is drawn in through the belt tube and cools the belts and bearings.

For the greatest amount of internal cooling, discharge static pressure should be kept to a minimum while keeping most of the pressure on the inlet side. Locate the fan at ends of the duct runs and near the discharge point in the system. This set-up will promote the ambient air cooling effect.

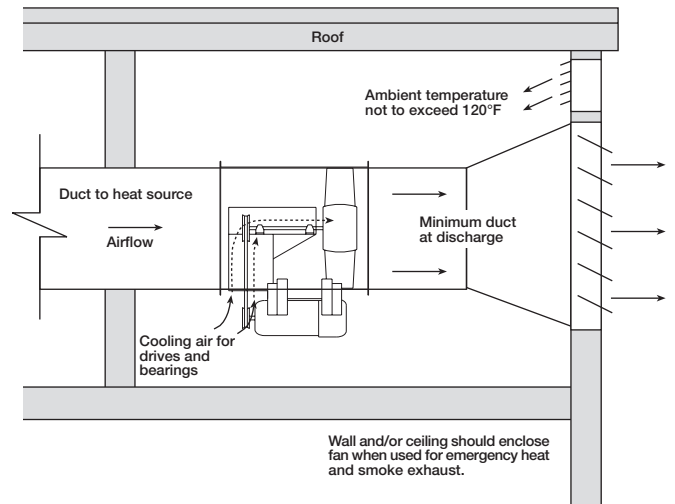

Field Coating Touch-Up Procedure for Scratched Areas

Standard coating color is RAL 7023 Concrete Grey. This procedure outlines the correct method for repairing minor scratches in the coating.

1. Scuff affected area to be repaired using medium sandpaper (provided) or medium scotch brite pad. Feather the edges.

TOUCH-UP PAINT REPAIR KIT CONTENTS

- One pint of Kem Kromik primer
- including a technical data sheet
- One pint of industrial enamel
- including a technical data sheet
- Four disposable foam brushes
- One sheet sandpaper
- Repair procedure details

2. Clean affected area to be touched up using an alkaline based cleaner and rinse.
3. Apply Kem Kromik primer using 1-inch foam brush (provided). Follow technical data sheet instructions.
4. Allow primer to dry a minimum of 2-1/2 hours before applying topcoat.
5. Apply topcoat with industrial enamel using 1-inch foam brush (provided). Follow technical data sheet instructions. Allow painted units to air-dry and cure before putting into service. See Technical Data sheets (included with kit) for detailed drying and cure schedules at different temperatures.

NOTE

While the manufacturer provides heavy-duty, quality products for marine environments, routine paint touch-ups may be required in coastal regions where salt or marine air could damage the coating on a TBI, TBI-CA or TBI-FS. The severe environment will accelerate the damage from any scratches or chips and it is recommended that those be repaired immediately.

To order additional coating repair kits, reference part number HAZ2597 PNT FIELD REPAIR KIT, RAL 7023 CONCRETE GREY. Contact factory with your fan's serial number for colors other than our standard.

Operation and Unit Start-Up

Electrical Connections

The electrical supply must be compatible with the fan motor voltage, phase and amperage capacity. The electrical supply line must be properly fused and conform to local and national electrical codes.

For **belt drive units**, the electrical supply line may be routed internally and exit the fan housing through a hole provided below the belt tube opening. The electrical supply line should then be either: (1) connected to an optional service disconnect switch, or (2) wired directly to the motor.

For **belt drive units in continuous high temperature installations**, the electrical supply must be kept out of the air stream. This means bringing the supply lines off the roof deck not through the fan. The electrical supply line should then be either: (1) connected to an optional service disconnect switch, or (2) wired directly to the motor.

The supply wires are then connected to an **optional** safety disconnect switch (if supplied) or wired directly to the motor.

For **belt drive units in emergency smoke removal installations**, the electrical supply must be kept out of the air stream. They may also require an isolated power supply so that if power is cut to the building in the event of a fire, the fan will continue to operate. Check the local and national electrical codes for emergency smoke removal fans.

Pre-Start-Up Checks

1. Check all fasteners for tightness. This includes motor bolts, bearing bolts, and any set screws or locking collars attaching the propeller to the shaft and shaft to the bearings.

If roof upblast configuration, lift the butterfly dampers to verify they open and close without binding.

2. Rotate the propeller by hand to ensure it turns freely and does not rub on the fan tube. Propeller rotation should always be checked by turning the unit on momentarily. Rotation should be in the same direction as the rotation decal affixed to the unit. Actual direction of rotation will vary by model. To reverse rotation on three phase installations, simply interchange two of the three electrical leads. For single phase installations, follow the wiring diagram located on the motor.

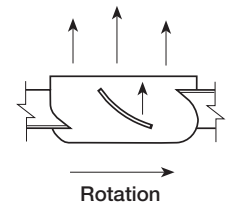

3. **Belt Drive Fan RPM** - adjustable motor pulleys are preset at the factory for the specified fan RPM. Fan speed can be increased by closing or decreased by opening the adjustable pulley. Multi-groove variable pitch pulleys must be adjusted an equal number of turns open or closed.
4. **Belt Drive Roof Upblast Fan RPM** - adjustable motor pulley on motors less than 10 HP is preset at the factory to the customer-specified RPM. Fan speed can be increased or decreased by adjusting the pitch diameter of the motor pulley. Multi-groove variable pitch pulleys must be adjusted an equal number of turns open. Motors 10 HP and larger will have a constant speed pulley.

NOTE

Any change, increase or decrease, in fan speed can represent a substantial increase in horsepower required from the motor. Always check motor load amperage and compare to nameplate rating when changing fan speed.

Maintenance

WARNING

Always disconnect power before working on or near a unit. Lock and tag the disconnect switch or breaker to prevent accidental power up. Failure to comply with this safety precaution could result in serious injury or death.

Once the fan has been put into operation, a periodic maintenance program should be set up to preserve the reliability and performance of the fan.

Items to be included in this program are:

- Fasteners and set screws
- Bearings
- Lubrication of bearings and motor
- Belts
- Removal of dust, dirt and debris
- Dampers for roof upblast configuration

IMPORTANT

Changing the belts or drives can significantly increase the amp draw of the motor. If changes are made to the drives or belts, the amps must be checked to assure no overamping.

Fasteners and Set Screws - Normal fan vibration has a tendency to loosen mechanical fasteners. Periodic inspection should include checking all fasteners, set screws, and locking collars attaching the propeller to the shaft and the shaft to the bearings. Loose bearing set screws and locking collars will lead to premature failure of the fan shaft.

Bearings on belt drive fans - Bearings are the most critical moving part of the fan and should be inspected at periodic intervals. Locking collars and set screws, in addition to fasteners attaching the bearing to the bearing plate, must be checked for tightness.

In a clean environment and temperature between 32° and 200°F (0 to 93°C), fan shaft bearings with grease fittings should be lubricated semi-annually using a high quality lithium based grease. Bearings operating outside these temperature parameters require special high or low temperature grease. If unusual environmental conditions exist, such as temperatures below 32°F (0°C) and above 200°F (93°C), high moisture, or contaminants, more frequent lubrication is required.

With the unit running, add grease very slowly with a manual grease gun. Be careful not to unseat the seal by over lubricating or using excessive pressure. Bearings without grease fittings are lubricated for life.

Bearings are one of the most critical parts of a fan and should be inspected at regular intervals. Locking collars, set screws and fasteners attaching the bearings to the fan should also be checked.

Model TBI fans are equipped with extended lubrication lines as standard. The grease fittings are located on the exterior of the fan housing next to the motor cover and should be wiped clean before adding grease.

Motors - Motor maintenance is generally limited to cleaning and lubrication. Cleaning should be limited to exterior surfaces only. Removing dust and grease build-up on the motor housing assists proper motor cooling.

IMPORTANT

Do not allow water or solvents to enter the motor or bearings. Under no circumstances should motors or bearings be sprayed with steam, water or solvents.

Lubrication of motors is intended only when fittings are provided. Many fractional horsepower motors are permanently lubricated for life and require no further lubrication. Motors supplied with grease fittings should be greased in accordance with the manufacturer's directions on the motor nameplate.

Belts - Premature belt failures are frequently caused by improper belt tension (either too loose or too tight), misaligned pulleys, or by prying belts on and off pulleys. The proper tension for operating a V-belt is the lowest tension at which the belts will not slip at peak load conditions. For initial tensioning, the proper belt deflection is 1/64-inch for each inch of belt span, measured half way between the pulley centers.

For example, if the belt span is 64 inches, the belt deflection should be one inch using moderate thumb pressure at midpoint of the drive (Fig. 2).

Check belt tension two times during the first 24 hours of operation, after 100 hours of operation, and periodically thereafter. To adjust belt tension, simply pivot the motor on the motor plate. Use the bolts in the slotted brackets and adjustment rods with bolts as adjustment points until proper belt tension is attained.

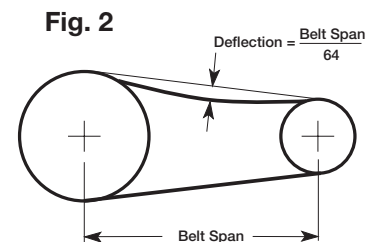

It is very important that the drive pulleys remain in proper alignment after adjustments. (Fig. 3)

When replacing belts, always use the same size and type as originally supplied by the factory. Check pulleys for wear and replace both pulleys and belts if wear is evident. Misalignment of pulleys will result in premature belt and bearing failure, noise and loss of fan efficiency.

Fan Bearing Lubrication - The bearings are carefully selected to match the maximum load and operating conditions of the specific class, arrangement and fan size.

The instructions provided in this manual and those provided by the bearing manufacturer will minimize any bearing problems. Bearings are the most critical part of the fan. Therefore, special care is required when mounting them on the unit and maintaining them.

Refer to the following charts and the manufacturer's instructions for grease types and intervals for various operating conditions. Never mix greases made with different bases. This will cause a breakdown of the grease and possible failure of the bearing.

Fig. 3

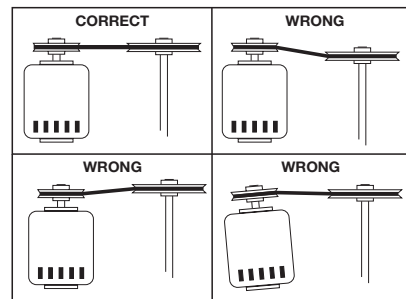
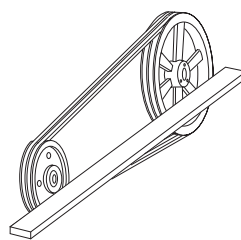

Standard Grease							
Recommended Fan Bearing Lubrication Schedule Relubrication Schedule in Months							
Fan RPM	Bearing Bore						
	1/2 - 1	1 1/8 - 1 1/2	1 5/8 - 1 7/8	1 15/16 - 2 3/16	2 7/16 - 3	3 3/16 - 3 1/2	3 15/16 - 4 1/2
To 250	12	12	12	12	12	12	10
500	12	12	11	10	8	7	5
750	12	9	8	7	6	4	3
1000	12	7	6	5	4	3	2
1250	12	6	5	4	3	2	1
1500	12	5	4	3	2	1	0.75
2000	12	3	3	2	1	0.5	0.25
2500	12	2	2	1	0.5	0.25	
3000	12	2	1	0.5	0.25		
3500	12	1	.5	.25			
4000	12	.5	.25				
5000	12	.25					
# of Shots**	4	8	8	10	16	25	41

Synthetic Grease							
Recommended Fan Bearing Lubrication Schedule Relubrication Schedule in Months							
Fan RPM	Bearing Bore						
	1/2 - 1	1 1/8 - 1 1/2	1 5/8 - 1 7/8	1 15/16 - 2 3/16	2 7/16 - 3	3 3/16 - 3 1/2	3 15/16 - 4 1/2
To 250	12	12	12	12	12	12	10
500	12	12	11	10	8	7	5
750	12	9	8	7	6	4	3
1000	12	7	6	5	4	3	2
1250	12	6	5	4	3	2	1
1500	12	5	4	3	2	1	0.75
2000	12	3	3	2	1	0.5	0.25
2500	12	2	2	1	0.5	0.25	
3000	12	2	1	0.5	0.25		
3500	12	3	2	.75			
4000	12	2	.5				
5000	12	1					
# of Shots**	4	8	8	10	16	25	41

* Lubricate interval is based on 12 hour per day operation and maximum 160 F housing temperature. For 24 hour per day operation, the interval should be cut in half.

** Lubricant should be added with the shaft rotating and until clean grease is seen purging from the bearing. The lubrication interval may be modified based on the condition of the purged grease. If bearing is not visible to observe purged grease, lubricate with number of shots indicated for bore size.

- For conditions including high temperatures, moisture, dirt or excessive vibration, consult the factory for a specific lubrication interval for your application.
- Lubricant should be a high quality lithium complex grease conforming to NLGI Grade 2. Factory recommends Mobilux EP-2.
- The use of synthetic lubricants will increase lubrication intervals by approximately 3 times.
- Storage periods of 3 months or longer require monthly rotation of the shaft and purging grease prior to storage and start-up.

IMPORTANT

Lubricate bearings prior to periods of extended shutdowns or storage and rotate shaft monthly to aid in preventing corrosion. If the fan is stored more than three months, the bearings should be purged with new grease prior to start-up.

Removal of dust, dirt and debris - Dirt clogs cooling openings on the motor housing, contaminates bearing lubricant, and collects on the propeller causing severe imbalance if left unchecked.

Periodically, thoroughly clean the exterior surface only of the motor. If optional motor cover is installed, remove it and clean the motor of dust, dirt and debris to aid in motor cooling. Use caution and do not allow water or solvents to enter the motor or bearings. Under no circumstances should motors or bearings be sprayed with steam or water.

Accumulations of dirt and debris on the propeller blades may cause an unbalanced condition resulting in excessive vibration and premature failure of the propeller and bearings.

Dampers for Roof Upblast Configuration - If exhausting dirty or contaminated air, the propeller and butterfly damper assembly should be cleaned periodically. Excessive buildup of dirt on the damper blades may cause binding and sticking blade hinges resulting in loss of fan performance. Clean as needed.

These fans have heavy-duty fusible link damper lifters under very high spring tension that must be pinned so they cannot be accidentally tripped when servicing the fan. The fusible link damper lifters are located under the butterfly damper blades. Point "A" shows where the safety pin **MUST** be placed when the fan is being serviced. Point "B" shows where the safety pin is placed for storage when the fan is in service.

Fan sizes 24, 30 and 36 also have fusible link damper lifters, but they do not have the ability to be pinned when servicing due to differences in lifter designs.

In either case, extreme care must be taken when working around the damper lifter assemblies or serious bodily injury or death may result.

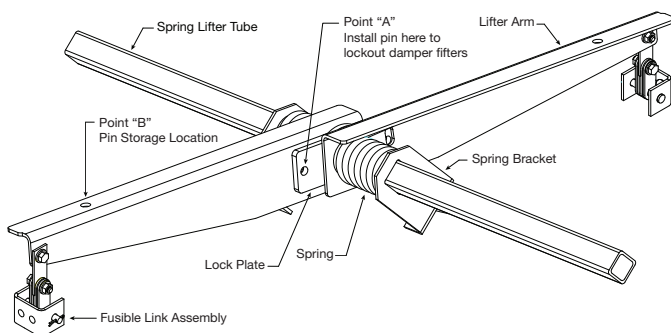

Parts List

Each fan bears a manufacturer's nameplate with embossed model and serial number. This information, in addition to the shown parts diagram, will assist the local Venco representative and the factory in providing service and replacement parts.

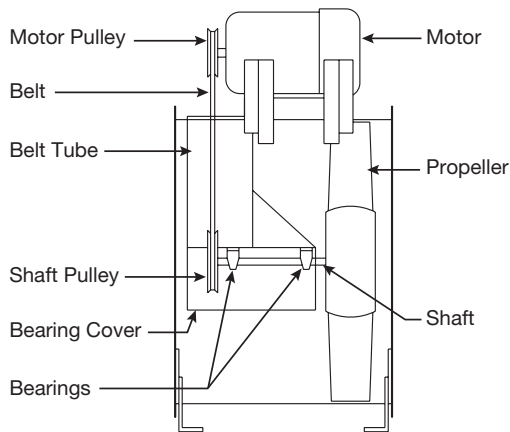
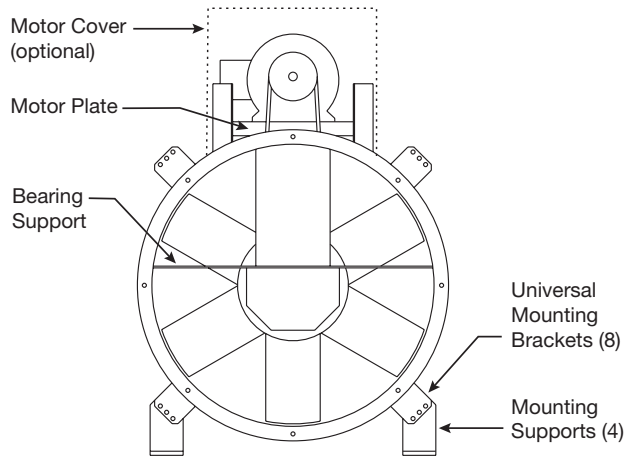

Registro de mantenimiento

Date _____ Time _____ AM/PM

Notes: _____

Date _____ Time _____ AM/PM

Notes: _____

Date _____ Time _____ AM/PM

Notes: _____

Date _____ Time _____ AM/PM

Notes: _____

Date _____ Time _____ AM/PM

Notes: _____

Date _____ Time _____ AM/PM

Notes: _____

Date _____ Time _____ AM/PM

Notes: _____

Date _____ Time _____ AM/PM

Notes: _____

Our Commitment

As a result of our commitment to continuous improvement, Venco reserves the right to change specifications without notice.

