

Installation, Operation and Maintenance Manual

Please read and save these instructions for future reference. Read carefully before attempting to assemble, install, operate or maintain the product described. Protect yourself and others by observing all safety information. Failure to comply with these instructions will result in voiding of the product warranty and may result in personal injury and/or property damage.

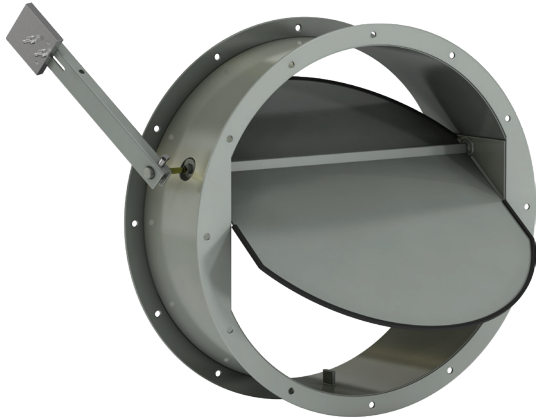

Receiving and Handling

Upon receiving dampers, check for both obvious and hidden damage. If damage is found, record all necessary information on the bill of lading and file a claim with the final carrier. Check to be sure that all parts of the shipment, including accessories, are accounted for.

Dampers must be kept dry and clean. Indoor storage and protection from dirt, dust and the weather is highly recommended. Do not store at temperatures in excess of 100°F (38°C).

Safety Warning

Improper installation, adjustment, alteration, service or maintenance can cause property damage, injury or death. Read the installation, operating, and maintenance instructions thoroughly before installing or servicing this equipment.

Table of Contents

General Instructions	2
Standard Components.	2
Counterbalance Adjustment	3
Damper Maintenance	4

This manual is the property of the owner and is required for future maintenance. Please leave it with the owner when the jobs is complete.

General Instructions

The following instructions should be followed when trying to adjust counterbalance weights on HB and HBR series dampers. This is not intended to be used to modification for use as a pressure relief damper.

The HB and HBR series backdraft dampers are adjusted for the specified flow direction at the factory. The external counterbalance is adjusted for “easy operation”. These instructions address adjustment of the blade counterbalance for the following:

- Damper mounting orientation and/or flow direction has changed in the field
- Damper requires excessive start-open pressure or does not close
- Blade seal has been removed in the field
- Counterbalance setting have been erroneously “adjusted” in the field

Single section wide dampers will have the external blade counterbalance on one (linkage) side of the damper. Dampers with two sections will have linkage on both sides of the damper assembly. Arms are usually mounted on every other axle, starting at the bottom, until the magnitude of the counterbalance requires arms on every axle. The steel airfoil models, HB-230 and HB-330, will require more counterbalance weights than model HB-120 with single thickness blade or models HB-110 and HB-240 with aluminum blades. The longer arms are angled so they will nest when installed on every axle. Venco’s policy is to distribute counterbalance weights evenly among the blades to minimize linkage loading and to improve blade closure.

Standard Components

Applicable Model	Component	Galvanized Part Number	Stainless Part Number
HB-110, HB-120, HBR-050	Axle Adapter, 3/8 in. to 3/4 in. square OD	370120	416343
All	3/4 in. Crankarm	652982	687738
All	3/8 in. - 16x2 Crankarm Bolt	415882	415924
All	3/8 in. - 16 Hex Nut for Crankarm	415457	415799
All	Short Counterweight Arm (8 1/2 in.)	657344	689404
All	Long Counterweight Arm (12 1/2 in.)	657343	683951
All	3/8 in.-16 set screw for short/long arm	415050	415763
All	3/8 in. -16 Weld nut/Hex nut for short/long arm	415127	415799
All	Counterweight plate, 2 1/2 in. x 3 1/2 in.	653143	687636
All	Counterweight plate, 3 1/2 in. x 3 1/2 in.	653142	687635
All	1/4 in.-20 Serrated Flange Nut	415455	415575
All	1/4 in.-20 x 3/4 in. Bolt	415490	415573
All	1/4 in. -20 x 1 1/4 in. bolt/ 1 1/2 in. bolt	415973	416103

Counterbalance Adjustment

1. Adjust FULL OPEN blade stop first. On most models, a bolt with a spacer is used through the top linkage clevis arm. Open and close damper to verify there is no interference between the axles and the nested counterweight arm.
2. Place damper in the installed mounting position and flow direction.
3. Adjust blade counterbalance at full open position first. Fan (flow) must not be operating. Rotate the damper blades to open. The crankarms or counterweight arms are generally 180° from the damper blade centerline. On very small dampers with aluminum blades, the crankarm may be inclined towards the damper outlet, due to the torque of the linkage. Adjust counterweight plate center distance until blades will start to close from full open position. Moving plate(s) out will increase counterbalance. It may be necessary to add or delete a plate. Counterweight plate quantity per arm should not vary more than 1/2 inch among the counterweight arms.
4. Close the damper. Blades should close completely (you can feel the blade edge seals make contact) without slamming. Note: Counterweight arms are welded to the axles as shipped. Arm adjustment will require weld to be removed and to be re-welded after modification.
 - If closing too hard, loosen the arm fastener to the axle and rotate top of the arm towards the upstream of air entering the side. Retighten the fastener.
 - If not closing, loosen the arm fastener to the axle and rotate the top of the arm towards downstream or discharge. Retighten the fastener.
5. Open the damper and recheck the full open operation. Readjust per step 3 if necessary. Recheck full closed position (step 4) as any modification at one position has a slight impact on the other.
6. Tighten all counterweight and arm fasteners securely.
7. Test damper closure by opening the damper blades and releasing from 1/4, 1/2, 3/4, and full open position. Damper should close from all positions without assistance.

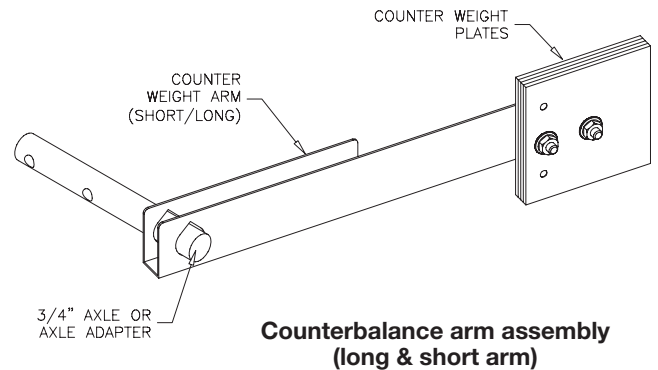
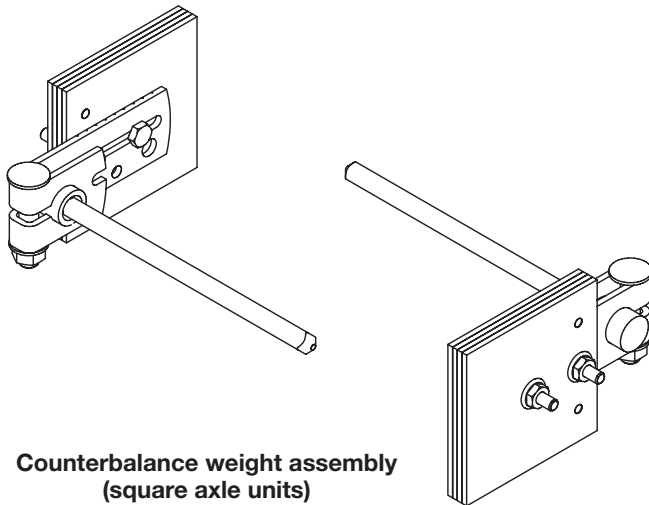

Damper Maintenance

Greenheck's dampers are designed to be trouble free and hassle free under normal operation. Dampers are to be installed square and straight so as to prevent binding during operation. The following annual damper maintenance suggestions will help to insure proper damper operation and increase the life expectancy of the damper.

Foreign Matter Over the course of time, dirt and grime may collect on damper surfaces. The damper surfaces should be cleaned to prevent hindrance to airflow.

Moving Parts Make sure that parts such as linkage, bearings, blades, etc. that are intended to move freely, can do so. Lubricating these components can prevent possible rusting and unnecessary friction increase. Use only a moli-spray oil or similar graphite based oil as regular lubricating oil will attract dirt.

Bearings. Plastic and press fit ball bearings (without grease fittings) do not require lubrication. Ball bearings with grease fittings should be lubricated as follows:

Maximum Duct Temperature			
°F	°C	Lubricant	Minimum Frequency
250	121	NLGI Grade 2 lithium 12-hydrostearate grease	Twice a year

Closure Remove foreign materials that may be interfering with blade closure or effective sealing of the blades with each other or with the frame. Inspect blade seals yearly and replace as necessary.

Operation While operating the damper through its full cycle, check to see that the blades open and close properly. If there is a problem, check for loose linkage.

Our Commitment

As a result of our commitment to continuous improvement, Venco reserves the right to change specifications without notice.



Phone: 1.833.881.0565 • Fax: 715.355.2399 • E-mail: info@vencoproducts.com • Website: www.vencoproducts.com