

Installation, Operation and Maintenance Manual

Please read and save these instructions for future reference. Read carefully before attempting to assemble, install, operate or maintain the product described. Protect yourself and others by observing all safety information. Failure to comply with these instructions will result in voiding of the product warranty and may result in personal injury and/or property damage.

Installation Instructions Without Standoff Bracket

Tools Required:

Hammer
 5/16 in. driver
 Electric drill
 9/16 in. drill bit
 7/16 in. wrenches (2)

Item	Qty	Description	Part Number
1	1	Manual Quadrant	475679
2	1	Bolt	415034
3	1	Flat washer	416206
4	1	Hex nut	415455
5	1	Wing nut	415885
6	1	Axle pin	454136
7	1	Axle clip	451890

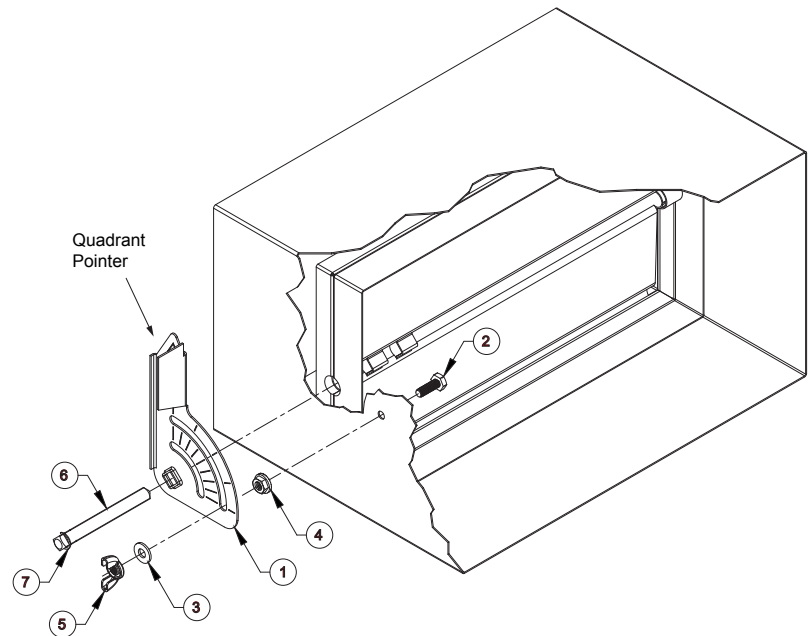

1. Install the damper in the duct. Place fasteners so that they do not interfere with operation of the blades. The end of the blade that has the lances will accept the quadrant drive pin. Place that side of the damper on the side of the duct where the quadrant is to be located.
2. Cut a hole through the duct over the lanced blade axle bearing. The hole should be large enough for the axle pin to slide through (approximately 9/16 in. diameter).
3. Slide the axle pin through the quadrant. Align the quadrant pointer with the blade as shown and then insert the pin into the damper blade lances.
4. Pound the axle pin into the damper blade until the quadrant is approximately 3/4 in. (19mm) away from the duct.
5. Rotate the quadrant and blade until the blades are at the full closed position. (The quadrant pointer will be approximately perpendicular to the centerline of the duct).
6. While holding the quadrant and blade in the closed position and using the end of the outer quadrant arc as a guide, drill a 1/4 in. (6mm) diameter hole through the duct. Drill the hole at the end of the arc that is furthest from the quadrant pointer.
7. Rotate the quadrant out of the way and insert the bolt from the inside of the duct. Secure the bolt to the duct using the hex nut.
8. Rotate the quadrant and blade back and position the quadrant over the bolt. Apply the flat washer and wing nut onto the bolt.
9. Pound the axle pin into the blade until the axle clip is within 1/8 in. (3mm) of the quadrant.
10. Using the quadrant lever, cycle the damper while checking for proper operation. Verify that the blade is free floating within the frame. Resolve any interference issues that prevent smooth operation.
11. Set the damper blade to the desired position and tighten the wing nut.

Installation Instructions With Standoff Bracket

Item	Qty	Description	Part Number
1	1	Manual Quadrant	475679
2	1	Bolt	415034
3	1	Flat washer	416206
4	1	Hex nut	415455
5	1	Wing nut	415885
6	1	Axle pin	452899
7	1	Axle clip	451890
8	2	Tek screw	415555
9	1	1½ in. Standoff bracket	742523
	1	2 in. Standoff bracket	742525

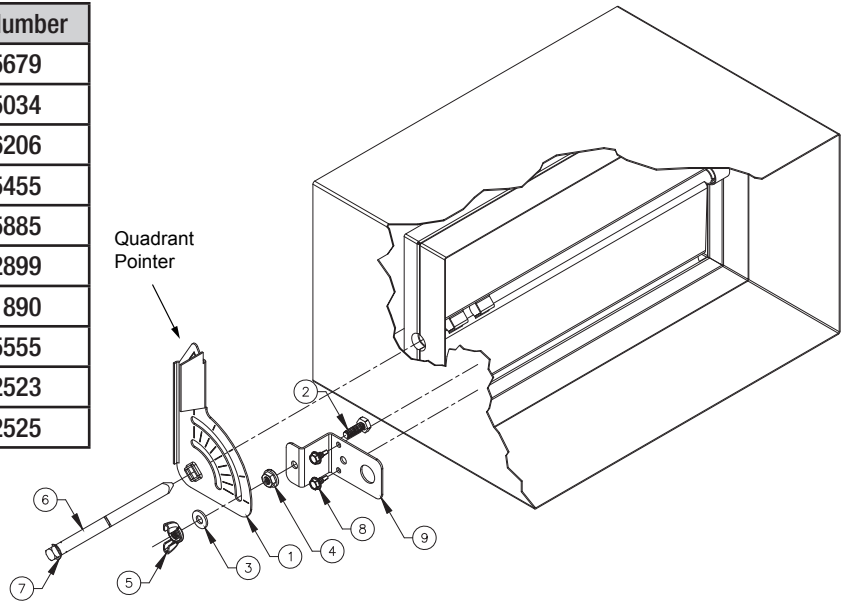

1. Install the damper in the duct. Place fasteners so that they do not interfere with operation of the blades. The end of the blade that has the lances will accept the quadrant drive pin. Place that side of the damper on the side of the duct where the quadrant is to be located.
2. Cut a hole thru the duct over the lanced blade axle bearing. The hole should be large enough for the axle pin to slide through (approximately $\frac{9}{16}$ in. diameter).
3. Insert the bolt into the standoff bracket as shown and secure using the hex nut.
4. Using the outer arc of the quadrant, attach the quadrant to the standoff bolt and apply the flat washer and wing nut. Slide the standoff assembly to the end of the arc that is furthest from the quadrant pointer and tighten the wing nut. Slide the axle pin through the quadrant.
5. Align the quadrant pointer with the blade as shown and then insert the axle pin into the damper blade lances. Pound the axle pin into the damper blade until the axle clip is approximately $2\frac{1}{4}$ in. (57mm) away from the duct.
6. Rotate the quadrant and blade until the blades are at the full closed position. (The quadrant pointer will be approximately perpendicular to the centerline of the duct).
7. Repositioned the standoff bracket as shown, then, attach the standoff bracket to the duct using two self- drilling Tek screws.
8. Using the quadrant lever, cycle the damper while checking for proper operation. Verify that the blade is free floating within the frame. Resolve any interference issues that prevent smooth operation.
9. Set the damper blade to the desired position and tighten the wing nut.

Installation Instructions For Cable Operator and Round Ceiling Cup

Tools Required:

- Hammer
- $\frac{5}{16}$ in. driver
- Electric drill
- $\frac{9}{16}$ in. drill bit
- $\frac{1}{4}$ in. bit driver
- $\frac{1}{8}$ in. hex key
- $\frac{5}{64}$ in. hex key

Item	Qty	Description	Part Number
1	1	Cable Operator	1036540
2	1	Axle pin	1036728
3	2	Tek screw	415555

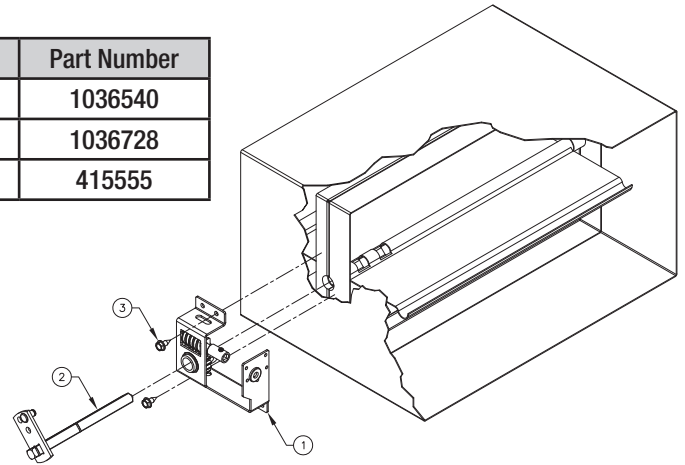

1. Install the damper in the duct. Place fasteners so that they do not interfere with operation of the blades. The end of the blade that has the lances will accept the cable operator drive pin. Place that side of the damper on the side of the duct where the cable operator is to be located.
2. Cut a hole through the duct over the lanced blade axle bearing. The hole should be large enough for the axle pin to slide through (approximately $\frac{9}{16}$ in. diameter).
3. Set damper blade to full open. Slide the axle pin through the cable operator. Orientate lever on axle pin to 45 degrees, as shown. Insert the pin into the damper blade lances.
4. Pound the axle pin into the damper blade until the cable operator is firmly secured between the duct and the lever on the axle pin.
5. Orientate cable operator such that it is running parallel to the duct. Install (2) Tek screws through screw holes in the cable operator, through ductwork, and into damper frame as shown.
6. Insert the end of the cable into the coupling on the cable operator. Tighten the set screw.
7. Use $\frac{1}{4}$ in. bit driver to rotate cable until set screws on cable operator gear are orientated such that they drive perpendicular into adjacent faces of the square axle pin. Tighten set screws.
8. Run the cable to termination point and secure the cable at 3 ft. intervals and every change in direction. Cables should be taut or nearly taut with a 4 in. minimum turn radius. For cable runs longer than 20 ft., use of conduit is recommended on straight run sections.
9. Attach the mounting bracket to the structural member such that the bottom of the bracket is flush with the top of the ceiling. (Illustration A)
10. Drill a $\frac{1}{2}$ in. diameter hole in the ceiling location that lines up with the centerline of the cable.
11. Use a $\frac{1}{4}$ in. bit driver to balance your damper.
12. Select the appropriate nylon cap to cover the opening, depending on the ceiling thickness. (Illustration A) Attach to exposed cable.

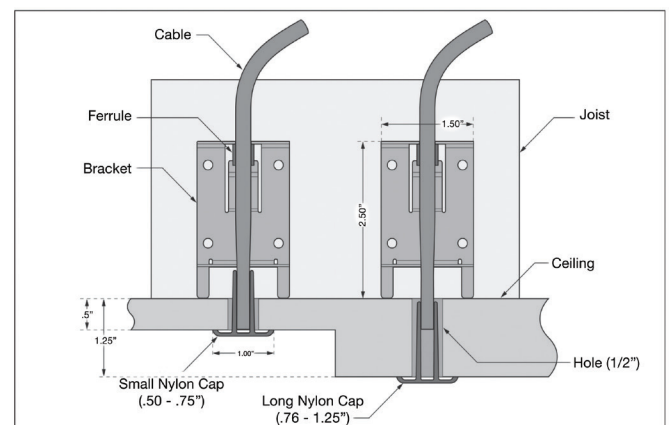

Illustration A

Installation Instructions For Cable Operator with Square Wall/Ceiling Plate

Tools Required:

Hammer
 $\frac{5}{16}$ in. driver
 Electric drill
 $\frac{1}{16}$ in. drill bit
 $\frac{1}{4}$ in. bit driver
 $\frac{1}{8}$ in. hex key
 $\frac{5}{64}$ in. hex key

Item	Qty	Description	Part Number
1	1	Cable Operator	1036540
2	1	Axle pin	1036728
3	2	Tek screw	415555

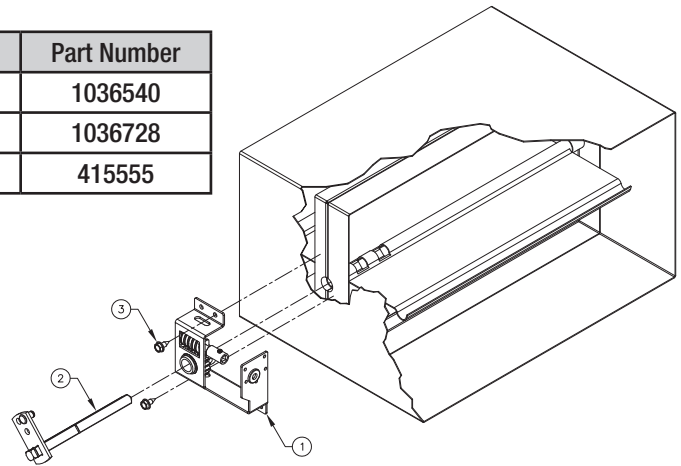

1. Install the damper in the duct. Place fasteners so that they do not interfere with operation of the blades. The end of the blade that has the lances will accept the cable operator drive pin. Place that side of the damper on the side of the duct where the cable operator is to be located.
2. Cut a hole through the duct over the lanced blade axle bearing. The hole should be large enough for the axle pin to slide through (approximately $\frac{5}{16}$ in. diameter).
3. Set damper blade to full open. Slide the axle pin through the cable operator. Orientate lever on axle pin to 45 degrees, as shown. Insert the pin into the damper blade lances.
4. Pound the axle pin into the damper blade until the cable operator is firmly secured between the duct and the lever on the axle pin.
5. Orientate cable operator such that it is running parallel to the duct. Install (2) Tek screws through screw holes in the cable operator, through ductwork, and into damper frame as shown.
6. Insert the end of the cable into the coupling on the cable operator. Tighten the set screw.
7. Use $\frac{1}{4}$ in bit driver to rotate cable until set screws on cable operator gear are orientated such that they drive perpendicular into adjacent faces of the square axle pin. Tighten set screws.
8. Run the cable to termination point and secure the cable at 3 foot intervals and every change in direction. Cables should be taut or nearly taut with a 4 in. minimum turn radius. For cable runs longer than 20 feet, use of conduit is recommended on straight run sections.
9. Fasten ceiling/wall plate to framing at the termination point, aligning the depth so that the box is properly aligned with the finished surface. (Illustration B)
10. For ceiling mount applications, use a $\frac{1}{4}$ in. bit driver to balance your damper.
11. For wall mount applications, move guide and bushing to top knockout. Pull the cable out towards you to allow driver access, then balance damper. Push the cable back in place once balancing is complete.
12. Install cover plate.

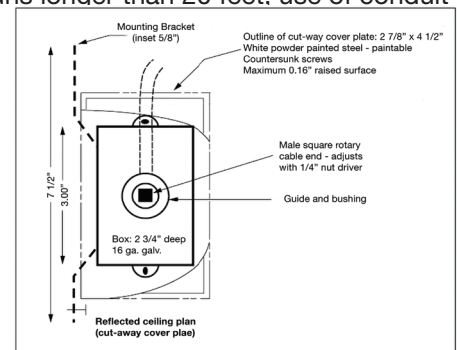

Illustration B

Our Commitment

As a result of our commitment to continuous improvement, Venco reserves the right to change specifications without notice.

Product warranties can be found online at Vencoproducts.com, either on the specific product page or in the literature section of the website at Vencoproducts.com/Resources.



Phone: 1.833.881.0565 • Fax: 715.355.2399 • E-mail: info@vencoproducts.com • Website: www.vencoproducts.com