

Installation, Operation and Maintenance Manual

Please read and save these instructions for future reference. Read carefully before attempting to assemble, install, operate or maintain the product described. Protect yourself and others by observing all safety information. Failure to comply with these instructions will result in voiding of the product warranty and may result in personal injury and/or property damage.



Receiving and Handling

Upon receiving dampers, check for both obvious and hidden damage. If damage is found, record all necessary information on the bill of lading and file a claim with the final carrier. Check to be sure that all parts of the shipment, including accessories, are accounted for.

Dampers must be kept dry and clean. Indoor storage and protection from dirt, dust and the weather is highly recommended. Do not store at temperatures in excess of 100°F (38°C).

Safety Warning

Improper installation, adjustment, alteration, service or maintenance can cause property damage, injury or death. Read the installation, operating, and maintenance instructions thoroughly before installing or servicing this equipment.

Table of Contents

Pre-Installation Guidelines	2
Multi-Section Assembly	3
Counterbalance Adjustment	4-7
EM/GM-30, 31, 32	4-5
EM-10, 11, 12	6
EM-40, 41, 42	7

Pre-Installation Guidelines

The basic intent of a proper installation is to secure the backdraft damper into the opening in such a manner as to prevent distortion and disruption of damper operation. The following items will aid in completing the damper installation in a timely and effective manner.

- 1) Check the schedules for proper damper locations within the building. Visually inspect the damper for damage.
- 2) Lift or handle damper using sleeve or frame. Do not lift damper using blades and linkage. When handling multiple sections assemblies, use sufficient support to evenly lift at each section mullion (see drawing). Do not drag, step on, apply excessive bending, twisting, or racking.

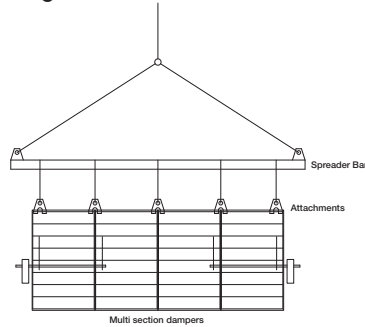

- 3) Do not install screws in damper frame that will interfere with unexposed blade linkage and prevent damper blades from opening and/or closing.
- 4) Damper must be installed into duct or opening square and free of twist or other misalignment. Damper must not be squeezed or stretched into duct or opening. Out of square, racked, twisted or misaligned installations can cause excessive leakage and/or torque requirements to exceed damper/actuator design.
- 5) Damper must be kept clean, dry and protected from dirt, dust and other foreign materials prior to and after installation. Examples of such foreign materials include but are not limited to:
 - a) Mortar dust
 - b) Drywall dust
 - c) Firesafing materials
 - d) Wall texture
 - e) Paint overspray
- 6) Damper should be sufficiently covered as to prevent overspray if wall texturing or spray painting will be performed within 5 feet (1.50 m) of the damper. Excessive dirt or foreign material deposits on damper can cause excessive leakage and/or torque requirements to exceed damper design.
- 7) ACCESS: Suitable access (counter balance adjustments) must be provided for damper inspection and servicing. Where it is not possible to achieve sufficient size access, it will be necessary to install a removable section of duct.
- 8) Prior to adjusting the dampers, verify system is operating as intended and designed. Applications where airflow could be uneven, such as a discharge fan, it is imperative to verify that at no point the maximum velocity exceeds the damper cataloged velocity.

Installation

- 1) Dampers ordered with "nominal" sizing are undersized $\frac{1}{4}$ in. (6mm) to facilitate ease of installation. For example, a 12 in. x 12 in. (305mm x 305mm) nominal damper will measure 11 $\frac{3}{4}$ in. x 11 $\frac{3}{4}$ in. (298mm x 298mm). Dampers ordered with "actual" sizing are not undersized. The duct or barrier opening that the damper is being mounted in should be $\frac{1}{4}$ in. (6mm) larger than the damper dimensions in both width and height. The opening should also be straight and level (**Figure 1**).

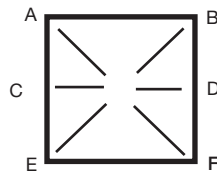

$$AF=BE$$

$$AB=CD$$

Do not twist or bow. Mount damper plumb in the opening.

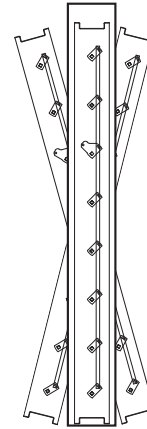
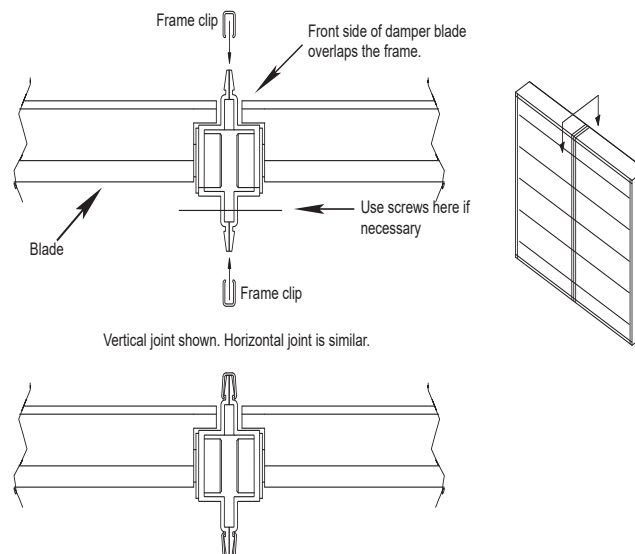

Figure 1

- 2) All installations require the entire exterior perimeter of the damper assembly to be secured to structural supports (example: concrete block wall, structural steel, etc.) which is supplied by others. The fastening method used to secure the damper to the structural support and the design of the structural support is the responsibility of field engineers.
- 3) Once the damper(s) are installed and secured, check if there is a shipping support band located in the middle of the damper side frames. This can be removed, if desired, as this no longer needed for structural support.
- Note:** Support band may be utilized for EM dampers 40 in. (1016 mm) high or greater and GM dampers 60 in. (1524 mm) or higher.

Multi-Section Assembly

When the finished damper assembly is made up of multiple sections, the sections will require field assembly. Frame clips are provided for this purpose. The frame clips are a snap fit component that fit over the joint between adjoining sections. The clips will require the use of a rubber hammer of similar tool to install as shown below. Install frame clips on the front side and backside of the assembly. For added strength, screws may be used on the backside of the frames in lieu of or in addition to the frame clip. Do not install screws on the front side of the frame where they could interfere with the operation of the blades. **Note: Used only on EM series dampers. Structural support reinforcement to be provided by others.**



Counterbalance Adjustment Procedure

The following instructions should be followed when attempting to maximize the counterbalance effect on the EM or GM model dampers. Be aware that when the balance setting is highly sensitive, friction wear, and contamination will have an adverse effect to the operation of the damper. The sensitivity of the counterbalance should only be set to meet the application requirements. The damper must be mounted square and plumb and operate freely before any weight adjustments are performed.

Counterbalance Adjustment for EM/GM-30, 31, and 32: Vertical Mount - Horizontal Airflow

There are several different adjustments that can be made to achieve the desired start open pressure and full open pressure. Start open pressure refers to the amount of static pressure required to start to open the blades. The full open pressure refers to the amount of static pressure required to fully open the damper blades.

EM-30, 31, 32 and GM- 30, 31,32		
Vertical Mount - Horizontal Airflow		
	Start Open	Full Open
Bending bracket to increase angle	Reduces pressure	Increases pressure
Sliding weights outward from blade	Reduces pressure	Reduces pressure
*Increasing torque (turns) on APC	Increases pressure	Increases pressure

* APC (Adjustable Pressure Controller) is an optional accessory

Step 1: Bend the Counterbalance Weight Bracket

Follow this procedure if a reduction of the start open pressure is desired.

- Locate the damper blade counterbalance weight stack
- Rotate the damper blades open and continue to bend the weight stack toward the damper sill slowly and in small increments (see Figure 1). The counterbalance bracket is designed to be bent by hand (see Figure 2)
- Repeat this step on all damper blades containing counterbalance weights and brackets
- If additional adjustment is needed, continue bending the counter balance brackets in small increments until the desired damper operation is achieved

Note: If additional adjustment or reducing the full open pressure is needed, continue to Step 2.



Figure 1: Bending counterbalance bracket away from blade towards the bottom (sill) of damper.

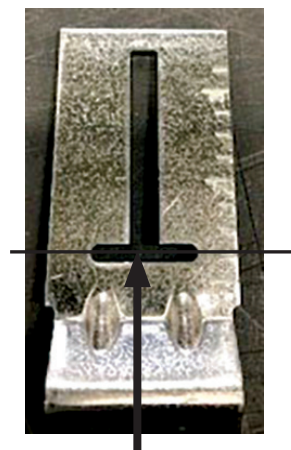

Figure 2:
Counterbalance
bracket

Step 2: Slide Weights Outward from Blade

Follow this procedure if a reduction of the full open pressure is desired. Note: Sliding the weights outward from the blade will also result in additional reduction in the start open pressure.

- Locate the $\frac{7}{16}$ in. (11 mm) nut on the weight stack and loosen until the weight stack may slide freely on the counterbalance bracket (see Figure 3A)
- Slide the weight stack outward from the damper blade in $\frac{1}{4}$ in. (6 mm) increments and tighten the $\frac{7}{16}$ in. (11 mm) nut securing the weight stack to the counter balance bracket (see Figure 3B).
- Repeat this step for all damper blades containing counterbalance brackets and weights and repeat this process if needed.

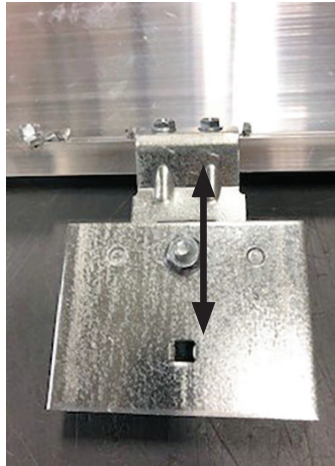

Figure 3A: weight stack on counterbalance bracket in factory position

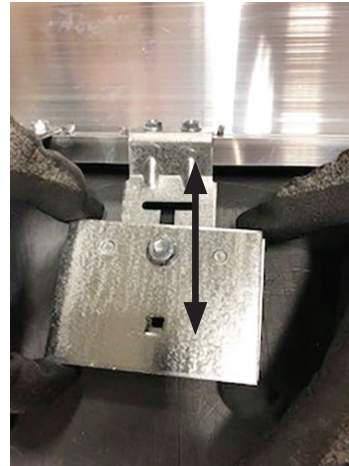

Figure 3B: Weight stack slid outward on counterbalance bracket

Step 3: Corrective Adjustment

If the damper blades are partially open or opening under no airflow after completing Step 2, reduce the bend of each counterbalance weight bracket slightly towards its factory position.

If the damper blades remain full open under no airflow, slide the counter balance weights inward towards the blade slightly on each blade. Repeat as needed until the damper blades close under no airflow.

Step 4: Adjustable Pressure Controller

If the damper(s) is equipped with an optional Adjustable Pressure Controller (APC) it can be used to increase the start open and full open pressure. See the APC Installation Operation Manual, Document 468292 for more details.

Counterbalance Adjustment for EM-10, 11, and 12: Horizontal Mount-Vertical Airflow Up

There are several different adjustments that can be made to achieve the desired start open pressure and full open pressure. Start open pressure refers to the amount of static pressure required to start to open the blades. The full open pressure refers to the amount of static pressure required to fully open the damper blades.

EM-10, 11, 12		
Horizontal Mount - Vertical Airflow Up		
	Start Open	Full Open
Bending bracket to reduce angle	Reduces pressure	Reduces pressure
Sliding weights outward from blade	Reduces pressure	Reduces pressure
*Increasing torque (turns) on APC	Increases pressure	Increases pressure

* APC (Adjustable Pressure Controller) is an optional accessory

Step 1: Bend the Counterbalance Weight Bracket

Follow this procedure if a reduction of the start open and the full open pressure is desired.

- Locate the damper blade counterbalance weight stack. This weight stack bracket is factory bent to 45 degrees.
- With the damper blades in the closed position, reduce the bend of the bracket by pushing the weight stack toward the damper head (top) slowly and in small increments (see Figure 4). The counter balance bracket is designed to be bent by hand. (see Figure 2)
- Repeat this step on all damper blades containing counterbalance weights and brackets.
- If additional adjustment is needed, continue bending the counter balance brackets in small increments until the desired damper operation is achieved.

Note: Bending this counterbalance bracket too far may result in the damper blades remaining open under minimal or zero airflow. If additional adjustment or reducing the full open pressure is needed, continue to Step 2.



Figure 4: Bending counterbalance to reduce angle

Step 2: Slide Weights Outward from Blade

Follow this procedure if additional reduction of the start open and the full open pressure is desired.

- Locate the $\frac{7}{16}$ in. (11 mm) nut on the weight stack and loosen until the weight stack may slide freely on the counterbalance bracket (see Figure 3A).
- Slide the weight stack outward from the damper blade in $\frac{1}{4}$ in. (6 mm) increments and tighten the $\frac{7}{16}$ in. (11 mm) nut securing the weight stack to the counter balance bracket (see Figure 3B).
- Repeat this step for all damper blades containing counterbalance brackets and weights.

Step 3: Corrective Adjustment

If the damper blades are partially open or opening under no airflow after completing Step 2, increase the bend of each counterbalance weight bracket slightly towards its factory position.

If the damper blades remain full open under no airflow, slide the counter balance weights inward towards the blade slightly on each blade. Repeat as needed until the damper blades close under no airflow.

Step 4: Adjustable Pressure Controller

If the damper(s) is equipped with an optional Adjustable Pressure Controller (APC) it can be used to increase the start open and full open pressure. See the APC Installation Operation Manual, Document 468292 for more details.

Counterbalance Adjustment for EM-40, 41, 42: Horizontal Mount - Vertical Airflow Down

There are several different adjustments that can be made to achieve the desired start open pressure and full open pressure. Start open pressure refers to the amount of static pressure required to start to open the blades. The full open pressure refers to the amount of static pressure required to fully open the damper blades.

EM-40, 41, 42		
Horizontal Mount - Vertical Airflow Down		
	Start Open	Full Open
Sliding weights outward from blade	Increases pressure	Increases pressure
*Increasing torque (turns) on APC	Increases pressure	Increases pressure

* APC (Adjustable Pressure Controller) is an optional accessory

Step 1: Slide Weights Outward From Blade

Follow this procedure if increasing the start open and the full open pressure is desired:

- Locate the $\frac{7}{16}$ in. (11 mm) nut on the weight stack and loosen until the weight stack may slide freely on the counterbalance bracket (see **Figure 4A**).
- Slide the weight stack outward from the damper blade in $\frac{1}{4}$ in. (6 mm) increments and tighten the $\frac{7}{16}$ in. (11 mm) nut securing the weight stack to the counter balance bracket (see **Figure 4B**).
- Repeat this step on all damper blades containing counterbalance weights and brackets

Step 2: Adjustable Pressure Controller

If the damper(s) is equipped with an optional Adjustable Pressure Controller (APC) it can be used to increase the start open and full open pressure. See the APC Installation Operation Manual, Document 468292 for more details.

