

Installation, Operation and Maintenance Manual

Please read and save these instructions for future reference. Read carefully before attempting to assemble, install, operate or maintain the product described. Protect yourself and others by observing all safety information. Failure to comply with these instructions will result in voiding of the product warranty and may result in personal injury and/or property damage.

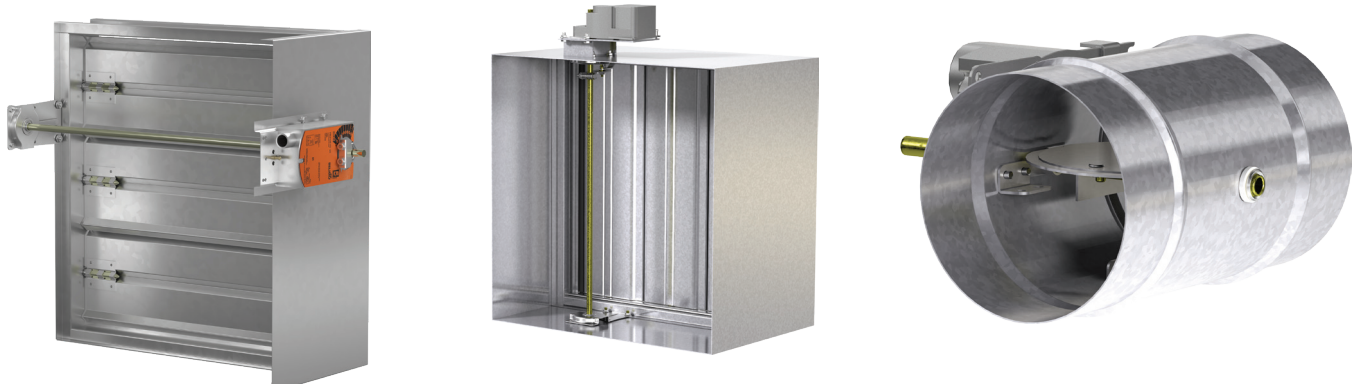

These instructions apply to installation of leakage rated smoke dampers supplied with factory installed damper actuators. Specific requirements in these instructions are mandatory. These instructions meet the requirements of UL 555S and UL classification R13317.

Receiving and Handling

Upon receiving dampers, check for both obvious and hidden damage. If damage is found, record all necessary information on the bill of lading and file a claim with the final carrier. Check to be sure that all parts of the shipment, including accessories, are accounted for.

Dampers must be kept dry and clean. Indoor storage and protection from dirt, dust and the weather is highly recommended. Do not store at temperatures in excess of 100°F (38°C).

Safety Warning

Improper installation, adjustment, alteration, service or maintenance can cause property damage, injury or death. Read the installation, operating, and maintenance instructions thoroughly before installing or servicing this equipment.

Table of Contents

General Information	2
Electrical Guidelines	2
Pre-Installation Guidelines	2
Smoke Damper Requirements	2
Installing Multiple Section Damper Assemblies	3
Maximum Assembly Tables	3
Location of Damper in Ductwork	4
Attaching Damper to the Duct	4
Sealing After Installing	4
Blade Orientation for Round Smoke Dampers	4
Actuator and Open/Close Indicator Connections	5
Fan Isolation Application	5
Damper Maintenance	6
Damper Troubleshooting	6

General Information

“UL CLASSIFIED (see complete marking on product)”
“UL CLASSIFIED to Canadian safety standards (see complete marking on product)”
Standard 555S (Listing #R13317)

This installation instructions is available on www.vencoproducts.com.

[Smoke Dampers](#)



Electrical Guidelines

Electrical Guidelines

All wiring shall be done in accordance with the National Electrical Code ANSI/NFPA-70 latest edition, any local codes that may apply, and wiring diagrams developed in compliance with the job or project design and specifications

Important!

Electrical input may be needed for this equipment. This work should be performed by a qualified electrician. Verify power before wiring actuator. Greenheck is not responsible for any damage to, or failure of the unit caused by incorrect field wiring. To avoid causing death or serious bodily harm to building occupants, follow all instructions carefully. Dampers must close completely to preserve the integrity of the fire smoke separation.

Pre-Installation Guidelines

The following items will aid in completing the damper installation in a timely and effective manner.

- 1) Check the drawings for proper damper locations within the building.
- 2) Lift or handle damper using sleeve or frame. Do not lift damper using blades or actuators.
- 3) Damper has label on outside of sleeve indicating a ‘No Screw’ area. Do not install screws into this area as screws may interfere with unexposed blade linkage and prevent damper blades from opening and/or closing.
- 4) Damper must be installed into duct or opening square and free of twist or other misalignment. Out of square, racked, twisted or misaligned installations can cause excessive leakage and/or torque requirements to exceed damper/actuator design.
- 6) Damper and actuator must be kept clean and protected from dirt, dust and other foreign materials prior to and after installation. Examples of such foreign materials include but are not limited to:
 - a) Mortar dust
 - b) Drywall dust
 - c) Firesafing materials
 - d) Wall texture
 - e) Paint overspray
- 7) Damper should be sufficiently covered as to prevent overspray if wall texturing or spray painting will be performed within 5 feet of the damper. Excessive dirt or foreign material deposits on the damper can cause excessive leakage and/or torque requirements to exceed damper/actuator design.
- 8) The Code Authority Having Jurisdiction (AHJ) must evaluate and provide approval of final installation where variations to these instructions are necessary.

Smoke Damper Requirements

Smoke dampers are required to close and prevent the passage of air and smoke through ducts or ventilation openings in smoke barriers. Smoke dampers are also applied in engineered smoke control systems to establish air pressure differentials and thereby prevent the spread of smoke.

Installing Multiple Section Damper Assemblies

A damper assembly is not restricted to a maximum number of sections, but must not exceed the section sizes and assembly sizes shown in the Maximum Assembly Table.

Some multiple section high damper assemblies require additional structural support between the damper frames. The following multiple section high damper assemblies require the use of either a support mullion between the damper frames as shown in **Figure 1** or individual sleeves around each row of dampers as shown in **Figure 2**:

- All horizontal mount dampers
- All vertical mount dampers over 72 in. (1829 mm) high and greater than 2 sections wide
- All vertical mount dampers rated for more than 4 in. wg (1 kPa)
- All vertical mount dampers that use fusible links as a closure device
- All SMD-401EF that are over one section high will need to be field assembled using the mullion plate provided

The damper sections must be attached together with #10 (3/4 in. max. [19mm]) sheet metal screws, 1/4 in. (6 mm) diameter nuts and bolts, tack or spot welds, or 3/16 in. (48 mm) diameter steel pop rivets. Attachments must be spaced a maximum of 6 in. (152 mm) on centers and a maximum of 2 in. (51 mm) from corners. Attachments must be made on front face and back face (air entering and air exiting side) of damper sections.

Note: Dampers ordered for individual installation may not be installed together. The full assembly size must be specified at the time the dampers are ordered.

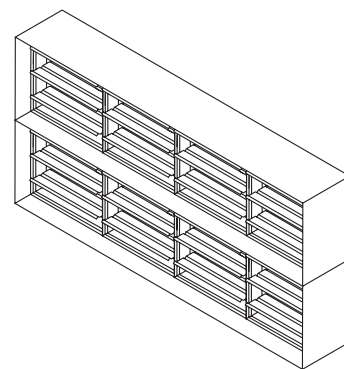
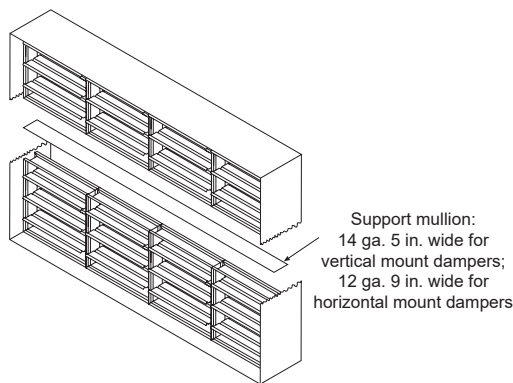

Figure 1: Single sleeve around outside with support mullion

Figure 2: Two individually sleeved units with no mullions

Maximum Assembly Tables

Damper model	Maximum Single Section Size in. (mm)	Maximum Overall Size for Multiple Section Dampers in. (mm)
SMD-201, 202, 203	36 x 48 or 32 x 50 (914 x 1219 or 813 x 1270)	144 x 100 or 288 x 50 (3658 x 2540 or 7315 x 1270)
SMD-201M, 202M	36 x 36 (914 x 914)	144 x 72 or 288 x 36 (3658 x 1829 or 7315 x 914)
SMD-301, 302	32 x 50 (813 x 1270)	128 x 100 or 256 x 50 (3251 x 2540) or (6502 x 1270)
SMD-301M, 302M	32 x 50 (813 x 1270)	128 x 100 or 256 x 50 (3251 x 2540) or (6502 x 1270)
SMD-401	48 x 60 (1219 x 1524)	192 x 120, 48 x 288, or 384 x 36 (4877 x 3048, 1219 x 7315 or 9754 x 914)
SMDR, SESMDR, SSSMDR	24 (610)	NA
SESMD-201, SSSMD-201	24 x 30 (610 x 762)	88 x 72 (2235 x 1829)
SMD-301V	50 x 32 (1270 x 813)	100 x 32 (2540 x 813)
SMD-401M	36 x 36 (914 x 914)	144 x 72 or 288 x 36 (3658 x 1829 or 7315 x 914)
SMD-401EF	48 x 60 (1219 x 1524)	192 x 120 or 96 x 240 (4877 x 3048 or 2438 x 6096)

Location of Damper in Ductwork

Place the damper assembly in its proper position relative to the barrier as shown (in **Figure 3**). The plane of the closed damper blades must be within 24 in. (610 mm) of the rated smoke barrier and before any duct inlets or outlets.

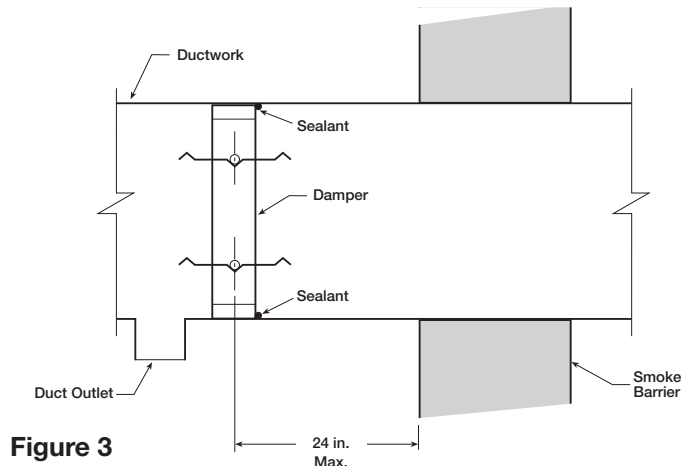

Attaching Damper to the Duct

Attach the damper to the duct using #10 sheet metal screws, $\frac{1}{4}$ in. (6 mm) diameter bolts and nuts, tack or spot welds, or $\frac{3}{16}$ in. (5 mm) diameter steel pop rivets. Attachments must be made at each flange spaced a maximum of 6 in. (152 mm) on centers and a maximum of 2 in. (51 mm) from corners on rectangular dampers, and on round dampers as follows:

- Ducts 22 in. (559 mm) diameter and smaller shall have 3 attachments.
- Ducts larger than 22 in. (559 mm) diameter up to and including 36 in. (914 mm) have five attachments.

Sealing After Installing

After installing the damper in the ductwork, seal the joint between the damper frame and the duct using Dow Corning RTV 732 sealant, GE1200 series silicone construction adhesive or Component Hardware SLT-5000 silicone sealant. Make sure to press the sealant into the joint to guarantee a proper seal. Make sure to press the sealant into the joint to guarantee a proper seal. Use the minimum amount of material required to completely seal the joint (see **Figure 3**).

Blade Orientation for Round Smoke Dampers

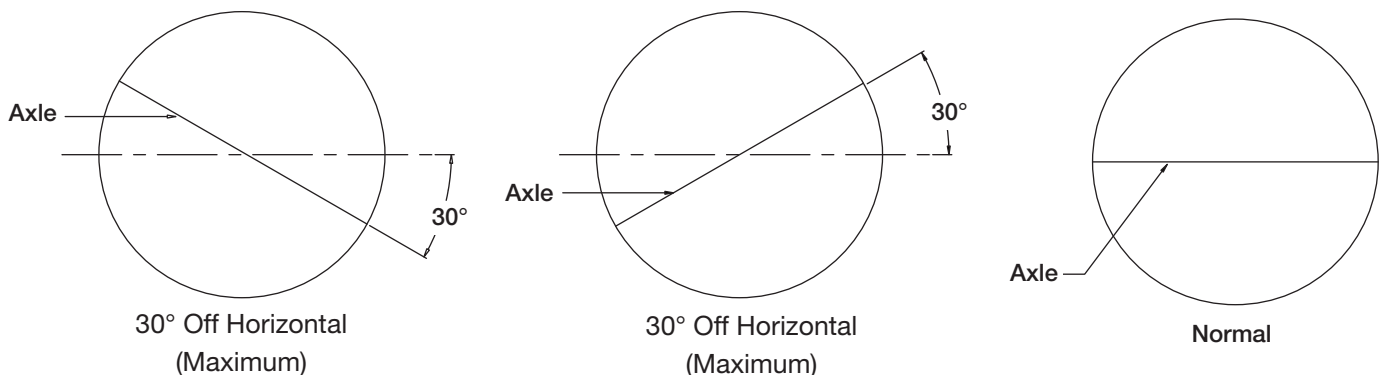

Actuator and Open/Close Indicator Connections

Actuator Connections

Electrical and/or pneumatic connections to damper actuators should be made in accordance with wiring and piping diagrams developed in compliance with applicable codes, ordinances and regulations (see **Electrical Guidelines**). A penetration through the damper sleeve may be necessary to accommodate the required wiring and/or pneumatic tubing for the actuator. Care should be taken to make this penetration as small as possible, and all wiring and sealing should be done according to NEC guidelines.

Open/Close Indicator

OCI - The OCI (open or closed indicator) option contains two single pole single throw switches used to indicate the damper blade position. The switches provide a positive open and closed signal and can be used in conjunction with remote indicator lights. Refer to **Figure 3** for wiring of the OCI option.

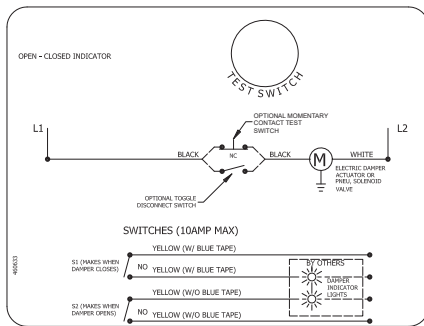

Figure 4: OCI

Ratings (Figure 4)

Integral Switch Type: Single Pole, single throw

Electrical Capacity: 10 Amps, 1/4 hp, 120 or 240 Vac

1/2 Amp, 125 Vdc;

1/4 Amp 250 Vdc

5 Amps, 120 Vac "L" (lamp load)

1.0 Amps, 24 Vac

1.5 Amps, 24 Vdc

Temperature Limit: 302°F (150°C) ambient or nominal

Fan Isolation Application

For air handling equipment isolation, leakage rated dampers are designed to operate with blades running horizontally. Dampers can be installed in a vertical or horizontal position. Sealants and damper seal materials meet the requirements for NFPA 90A for smoke developed rating (≤ 50) and flame spread index (≤ 25) as tested per UL 723/ASTME84-91 A/NFPA 255. Dampers can be attached to the fan system discharge or inlet without being 24 in. (610 mm) of a smoke barrier when used as an air handling equipment isolation damper.

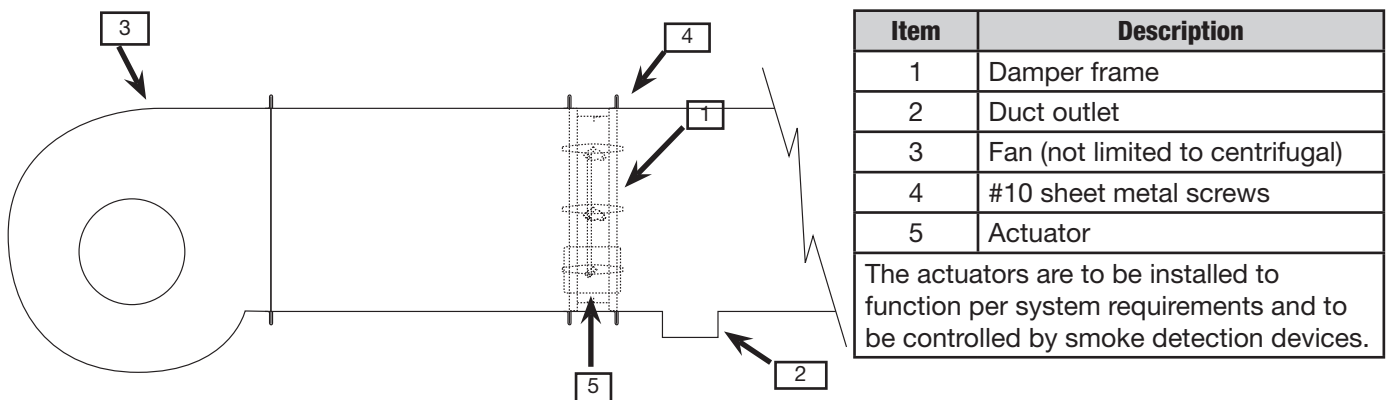

Damper Maintenance

Dampers do not typically require maintenance as long as they are kept dry and clean. If cleaning is necessary, use mild detergents or solvents. If lubrication is desired for components such as axle bearings, jackshaft bearings and jamb seals, do not use oil-based lubricants or any other lubricants that attract contaminants such as dust.

Dampers and their actuator(s) must be maintained, cycled, and tested a minimum in accordance with:

- The latest editions of NFPA 80, 90A, 92, 101, 105, UL864, AMCA 503-03 and local codes.
- Actuator manufacturer recommendations.

Damper Troubleshooting

The following is a possible cause and correction list for common concerns with the dampers.

Symptom	Possible Cause	Corrective Action
Damper does not fully open and/or close	Frame is 'racked' causing blades to bind on jamb seals	Adjust frame such that it is square and plumb
	Actuator linkage loose	Close damper, disconnect power, adjust and tighten linkage
	Defective motor	Replace
	Screws in damper linkage	Damper installed too far into wall. Move out to line as designated on damper label
	Contaminants on damper	Clean with a non-oil based solvent (see Damper Maintenance)
RRL or TOR sensor tripped	Heat	Push reset button located on backside of RRL or TOR
Damper does not operate	No power supplied to the actuator	Add power supply

