

Installation, Operation and Maintenance Manual

Please read and save these instructions for future reference. Read carefully before attempting to assemble, install, operate or maintain the product described. Protect yourself and others by observing all safety information. Failure to comply with these instructions will result in voiding of the product warranty and may result in personal injury and/or property damage.



Table of Contents

Electrical Guidelines	2
Pre-Installation Guidelines.....	2
Installation	3-4
Maintenance	4
Troubleshooting	4

Safety Warning

Improper installation, adjustment, alteration, service or maintenance can cause property damage, injury or death. Read the installation, operating, and maintenance instructions thoroughly before installing or servicing this equipment.

Receiving and Handling

Upon receiving dampers, check for both obvious and hidden damage. If damage is found, record all necessary information on the bill of lading and file a claim with the final carrier. Check to be sure that all parts of the shipment, including accessories, are accounted for.

Dampers must be kept dry and clean. Indoor storage and protection from dirt, dust and the weather is highly recommended. Do not store at temperatures in excess of 100°F (38°C).

Caution: UV Lights

The dampers should not be mounted or stored in direct line of sight to UV lights.

Electrical Guidelines

Electrical Guidelines

All wiring shall be done in accordance with the National Electrical Code ANSI/NFPA-70 latest edition, any local codes that may apply, and wiring diagrams developed in compliance with the job or project design and specifications.

Important!

Electrical input may be needed for this equipment. This work should be performed by a qualified electrician. Verify power before wiring actuator. Venco is not responsible for any damage to, or failure of the unit caused by incorrect field wiring. To avoid causing death or serious bodily harm to building occupants, follow all instructions carefully. Dampers must close completely to preserve the integrity of the fire smoke separation.

This manual is the property of the owner and is required for future maintenance. Please leave it with the owner when the job is complete.

Pre-Installation Guidelines

The following items will aid in completing the damper installation in a timely and effective manner.

1) Check the drawings for proper damper locations within the building. Visually inspect the damper for damage.

2) Lift or handle damper using sleeve or frame. Do not lift damper using blades or actuators. When handling multiple section assemblies, use sufficient support to evenly lift at each section mullion (see drawing). Do not drag, step on, apply excessive bending, twisting, or racking.

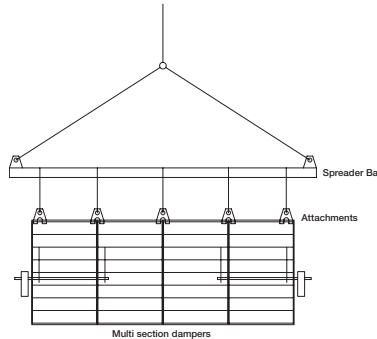

3) Do not install screws into the damper frame that will interfere with unexposed blade linkage and prevent damper blades from opening and/or closing.

4) Damper must be installed into duct or opening square and free of twist or other misalignment. Out of square, racked, twisted or misaligned installations can cause excessive leakage and/or torque requirements to exceed damper/actuator design.

5) Damper and actuator must be kept clean and protected from dirt, dust and other foreign materials prior to and after installation. Examples of such foreign materials include but are not limited to:

- a) Mortar dust
- b) Drywall dust
- c) Firesafing materials
- d) Wall texture
- e) Paint overspray

6) Damper should be sufficiently covered as to prevent overspray if wall texturing or spray painting will be performed within 5 feet of the damper. Excessive dirt or foreign material deposits on the damper can cause excessive leakage and/or torque requirements to exceed damper/actuator design.

7) ACCESS: Suitable access (actuators can be maintained, etc.) must be provided for damper inspection and servicing. Where it is not possible to achieve sufficient size access, it will be necessary to install a removable section of duct.

Installation for Channel or Flange Frame

Failure to follow instructions will void all warranties.

1) Duct opening or opening square should measure to the inside damper dimension and should be straight and level.

2) A Damper assembly is not restricted to a maximum number of sections but, must not exceed the section sizes and overall sizes shown below.

In. (mm)	ICD-44	ICD-45
Maximum Single Section	60 x 78 (1524 x 1981)	
Maximum Multi-Section	Channel, Single, or Reverse Flange	180 x 156 (4572 x 3962)
	Quick Connect	96 x 156 (2438 x 3962)

3) The damper sections must be attached together with #10 x 3/4 in. (19mm) max. sheet metal screws, 1/4 in. (6mm) diameter nuts and bolts, tack or spot welds, or 3/16 in. (4mm) diameter steel pop rivets. Attachments must be spaced a maximum of 12 in. (305mm) on centers and a maximum of 2 in. (51mm) from corners. Attachments must be made on front face and back face (air entering and air exiting side) of damper sections (see Figures 1 & 2).

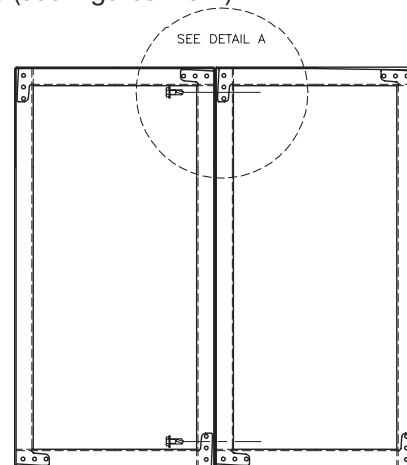

Figure 1

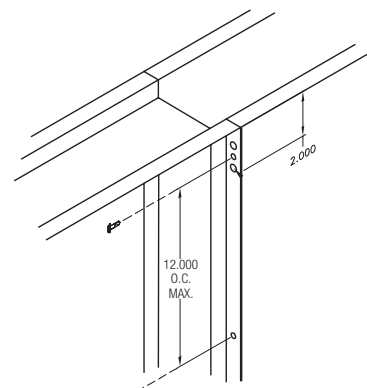

Figure 2

- 4) Multiple section damper assemblies require field supplied horizontal mullions and vertical supports to keep each damper section plum and square. The mullions and supports shall be designed by field engineers based on the size of the damper assemblies and application conditions (system velocity and pressure).
- 5) If damper actuator is to be mounted out of the airstream, the extension pin should extend approximately 6 inches (152mm) beyond the frame. On jackshafted units, the jackshaft should extend through the jackshaft bearing assembly and approximately 6 inches (152mm) beyond the frame.
- 6) Individual damper sections, as well as entire multiple section assemblies must be completely square and free from racking, twisting, or bending. Measure diagonally from upper corners to opposite lower corners of each section (see Figures 3 & 4)
- 7) Damper blades, axles, and linkage must operate without binding. Before system operation, cycle dampers after installation to assure proper operation. On multiple section assemblies, all sections should open and close simultaneously.

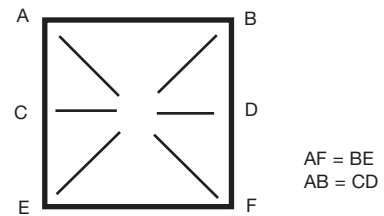
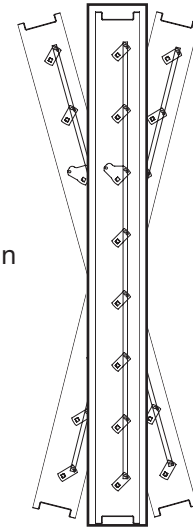

Figure 3



Do not twist or bow. Mount damper plumb in the opening.

Figure 4

Installation for Quick Connect Frame

- 1) These instructions apply to the quick connect frame attaching to a TDC or TDF flange system.
- 2) To seal the two flange systems together Neoprene or Butyl gasket may be applied to the mating surfaces (Figure 5).
- 3) Align the quick connect frame and flange system together. An optional $\frac{3}{8}$ in. (9mm) bolt may be used in the corners to help with the alignment. These bolts do not have to be removed.
- 4) Install the metal cleat (Figure 6) or #10 TEK screw with the following recommend spacing:

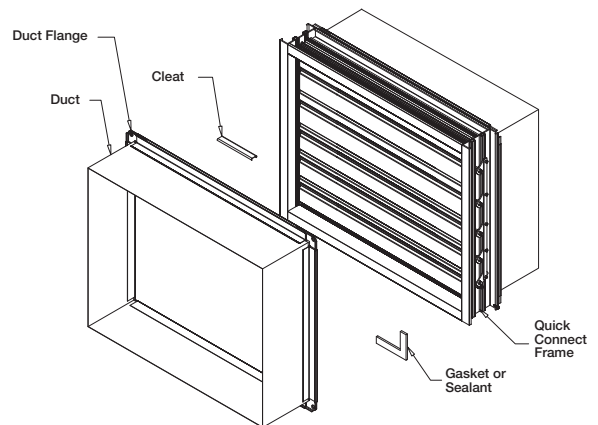

Figure 5: Quick Connect Frame

Width or Height	Cleats or screws per side
< 24 in. (610mm)	1
≥ 24 in. < 36 in. (610 - 914mm)	2
≥ 36 in. < 54 in. (914 - 1372mm)	3
≥ 54 in. < 72 in. (1372 - 1829mm)	4
≥ 72 in. (1829mm)	5

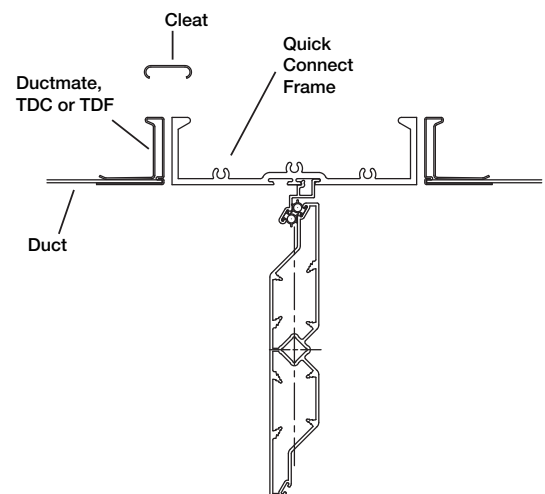

Figure 6

Damper Maintenance

Venco's dampers are designed to be trouble free and hassle free under normal operation. Dampers are to be installed square and straight so as to prevent binding during operation. The following annual damper maintenance suggestions will help to insure proper damper operation and increase the life expectancy of the damper.

Foreign Matter Over the course of time, dirt and grime may collect on the damper surfaces. The damper surfaces should be cleaned to prevent hindrance to airflow.

Moving Parts Make sure that parts such as linkage, bearings, blades, etc. that are intended to move freely, can do so. Lubricating these components can prevent possible rusting and unnecessary friction increase. Use only a moli-spray oil or similar graphite based oil as regular lubricating oil will attract dirt.

Bearings. Synthetic, oil impregnated, and ball bearings (without grease fittings) do not require lubrication. Ball bearings with grease fittings require only minimal grease.

Closure Remove foreign materials that may be interfering with blade closure or effective sealing of the blades with each other or with the frame.

Operation While operating the damper through its full cycle, check to see that the blades open and close properly. If there is a problem, check for loose linkage, especially at the actuator. Tighten the linkage where required.

Damper Trouble Shooting

The following is a list of possible solutions with

Symptom	Possible Cause	Corrective Action
Damper does not fully open and or close	Frame is 'racked' causing the blades to bind on jamb seals	Adjust frame such that it is square and plumb
	Actuator linkage is loose	Close damper, disconnect power, adjust and tighten linkage
	Actuator not working	Replace
	Actuator linkage hitting wall or floor	Damper installed too far into the wall. Move out to designated line on damper label
	Screws in damper linkage	Remove screws
	Contaminants on the damper	Clean with a non-oil based solvent (see Damper Maintenance)

Our Commitment

As a result of our commitment to continuous improvement, Venco reserves the right to change specifications without notice.



Phone: 1.833.881.0565 • Fax: 715.355.2399 • E-mail: info@vencoproducts.com • Website: www.vencoproducts.com