

## Installation, Operation and Maintenance Manual

Please read and save these instructions for future reference. Read carefully before attempting to assemble, install, operate or maintain the product described. Protect yourself and others by observing all safety information. Failure to comply with these instructions will result in voiding of the product warranty and may result in personal injury and/or property damage.



These instructions apply to 1½ and 3 hour rated fire dampers mounted in: 1) masonry, block, or stud walls (blades must be horizontal) and 2) concrete floors. Specific requirements in these instructions are mandatory. Dampers must be installed in accordance with these instructions to meet the requirements of UL 555.

**Note:** Fire dampers are manufactured and labeled for either vertical or horizontal installation. The dampers must be installed in accordance with labeling.

## Table of Contents

General Information . . . . .	2
Pre-Installation Guidelines . . . . .	2
Preparation of Openings . . . . .	3
Clearances Required Between Damper Sleeves & Wall/ Floor Openings. . . . .	4
Installing Multiple Section Assemblies. . . . .	4
Maximum Assembly Tables . . . . .	5
Sleeve Requirements . . . . .	5
Inserting Damper into Wall/Floor Openings . . . . .	6
Securing the Damper/Sleeve Assembly to Wall/Floor Openings. . . . .	7
Duct to Sleeve Connection . . . . .	9
Damper Commissioning and Periodic Testing. . . . .	12
Damper Maintenance . . . . .	12
Damper Troubleshooting. . . . .	12

### Receiving and Handling

Upon receiving dampers, check for both obvious and hidden damage. If damage is found, record all necessary information on the bill of lading and file a claim with the final carrier. Check to be sure that all parts of the shipment, including accessories, are accounted for.

Dampers must be kept dry and clean. Indoor storage and protection from dirt, dust, and the weather is highly recommended. Do not store at temperatures in excess of 100°F (38°C).

### SAFETY WARNING

Improper installation, adjustment, alteration, service or maintenance can cause property damage, injury or death. Read the installation, operating, and maintenance instructions thoroughly before installing or servicing this equipment.

## General Information

**“UL CLASSIFIED (see complete marking on product)”**

**“UL CLASSIFIED to Canadian safety standards (see complete marking on product)”**

Standard 555 (Listing #R13317)

Online version to this  
Installations at  
[www.vencoproducts.com](http://www.vencoproducts.com).

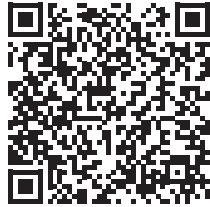

[Curtain Fire Dampers  
Instructions](#)

## Pre-Installation Guidelines

The following items will aid in completing the damper installation in a timely and effective manner.

- 1) Check the schedules for proper damper locations within the building. Visually inspect the damper for damage and verify that the fusible link is in place and has not activated. Never install a fire damper without the proper UL approved fusible link in place. Visually inspect the fusible link to verify its not damaged. Replace link as necessary.
- 2) Lift or handle damper using sleeve or frame. Do not lift damper using blades.
- 3) Dampers have a label indicating the required mounting orientation. When the mounting orientation is horizontal, the 'K side' must be up. Care must be taken to ensure that the indicated orientation is adhered to.

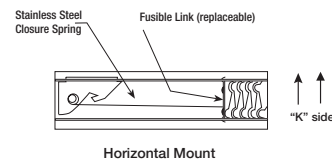

- 4) Damper must be installed into duct or opening square and free of twist or other misalignment.
- 5) Damper must be kept clean and protected from dirt, dust and other foreign materials prior to and after installation. Examples of such foreign materials include but are not limited to:
  - a) Mortar dust
  - b) Drywall dust
  - c) Firesafing materials
  - d) Wall texture
  - e) Paint overspray
- 6) Damper should be sufficiently covered as to prevent overspray if wall texturing or spray painting will be performed within 5 feet of the damper.
- 7) Caulking is not necessary, nor is it allowed, between the damper sleeve and the wall or floor opening (annular space). However, caulking may be applied to the retaining angles.
- 8) ACCESS: Suitable access (such that the fusible link may be removed and the damper's blade stack may be reset, etc.) must be provided for damper inspection and servicing. Where it is not possible to achieve sufficient size access, it will be necessary to install a removable section of duct. (Refer to NFPA 90A).
- 9) The Code Authority Having Jurisdiction (AHJ) must evaluate and provide approval of final installation where variations to these instructions are necessary.

# Preparation of Openings

- Frame wall openings as shown below (see Figure 1, 2, and 2A).
- Gypsum wall board must be fastened 12 in. (305 mm) on center to all stud and runner flanges surrounding opening.
- Prepare opening between studs and sleeve assembly as shown below (see Figure 3 & 4).
- All construction and fasteners must meet the requirements of the appropriate wall design (See UL Fire Resistance Directory) and/or local codes.

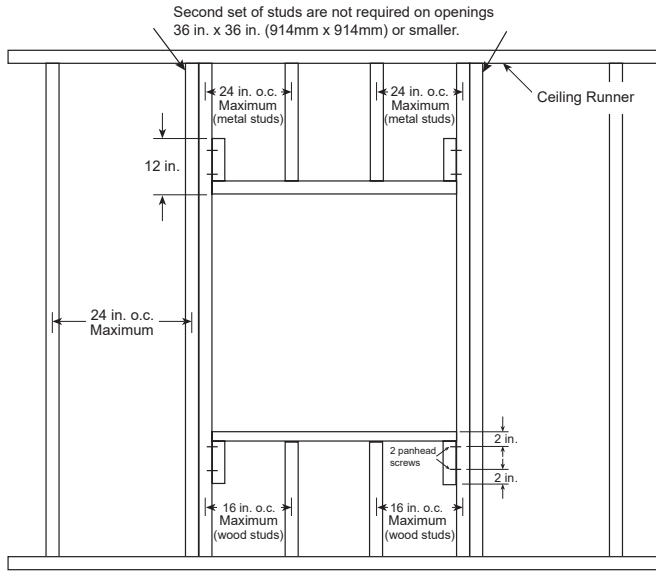

Figure 1

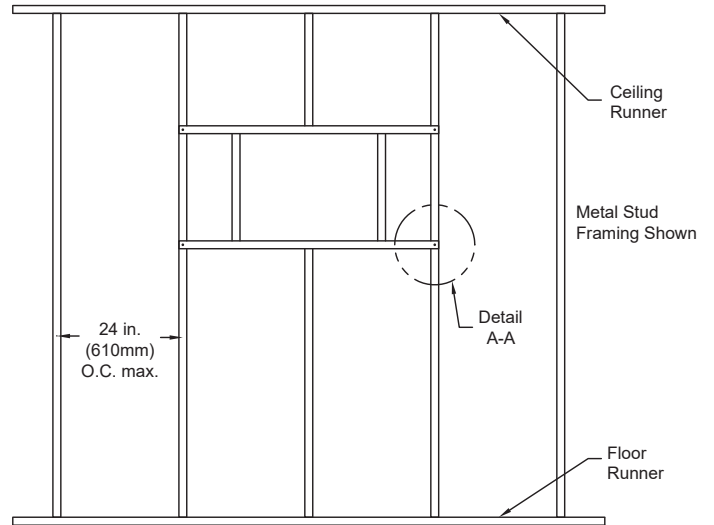

Figure 2

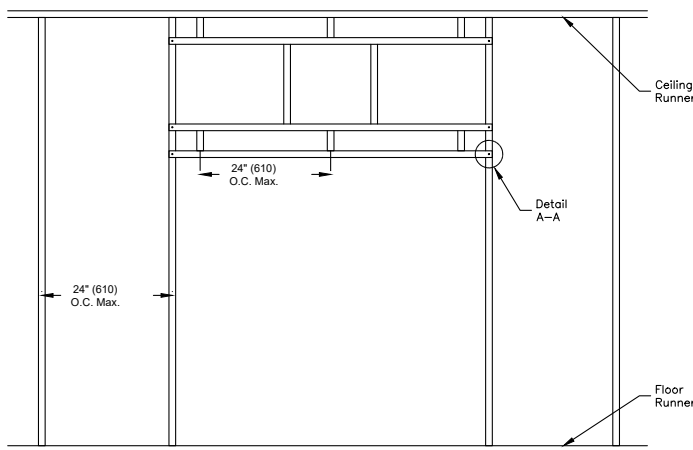
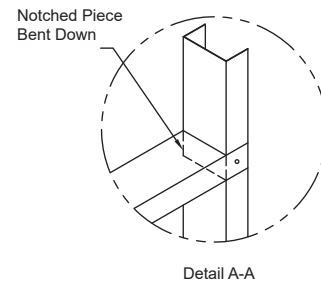

Figure 2A



Detail A-A

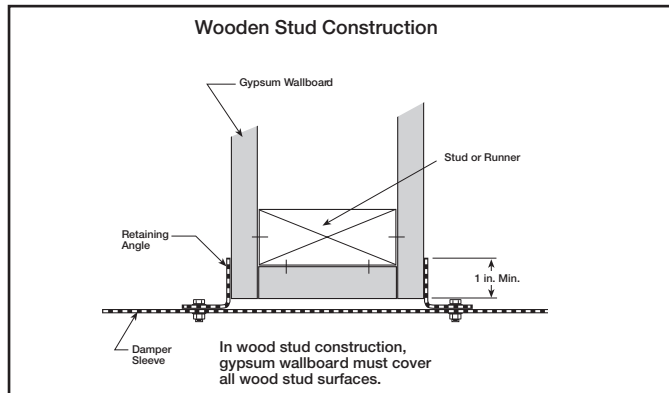

Figure 3 (2 sided angle installation shown)

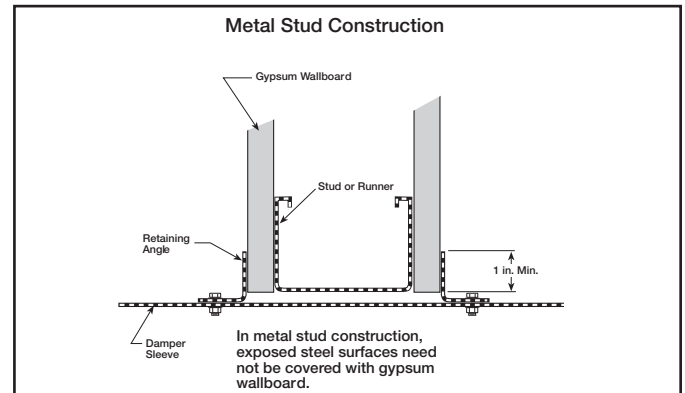

Figure 4 (2 sided angle installation shown)

# Clearances Required Between Damper Sleeves & Wall/Floor Openings

## Two-Sided Angle Installation

Two-sided angle installations require clearances for thermal expansion between the damper sleeve and the wall/floor opening. The minimum required clearances are:

- For galvanized steel dampers and sleeves:  $\frac{1}{8}$  in. per foot (3 mm per .3 m) of damper width and  $\frac{1}{8}$  in. per foot (3 mm per .3 m) height with a minimum clearance of  $\frac{1}{4}$  in. (6 mm). The total gap may be up to 6 in. (152 mm) larger than the damper, with a maximum gap between the damper and the opening of 3 in. (76 mm) per side as long as the retaining angles overlap the wall/floor by a minimum of 1 in. (25 mm).
- For stainless steel dampers and stainless steel or galvanized sleeves:  $\frac{3}{16}$  in. per foot (5 mm per .3 m) of damper width and height with a minimum clearance of  $\frac{1}{4}$  in. (6 mm), maximum of 2 in. (51 mm).

### Example:

A 12 in. x 12 in. (305 mm x 305 mm) will require a minimum clearance of  $\frac{1}{4}$  in. (6 mm) width and  $\frac{1}{4}$  in. (6 mm) on height

A 48 in. x 12 in. (1219 mm x 305 mm) damper will required a minimum clearance of  $\frac{1}{2}$  in. (13 mm) on width and  $\frac{1}{4}$  in. (6 mm) on height.

These are total clearances (ignoring fastener heads) and do not need to be equally spaced around the damper.

Although the minimum requirements are listed above, for ease of installation the following are the recommended clearances for galvanized dampers:

- Width/Height of 48 in. (1219 mm) or less -  $\frac{1}{2}$  in. (13 mm) clearance
- Width/Height between 48.01 in. (1220 mm) and 96 in. (2438 mm): 1 in. (25 mm) clearance
- Width/Height greater than 96 in. (2438 mm):  $1\frac{1}{2}$  in. (38 mm) clearance

## Single Side Angle Installation

On vertical mount single side angle installations there are no minimum clearance requirements between the wall opening and the damper sleeve. However, to facilitate installation, the width and height of the opening in the wall may be up to  $1\frac{1}{2}$  in. (38 mm) greater than the width and height of the damper.

On horizontal mount single side angle installations a minimum clearance is required between the outside of the damper sleeve and the floor opening of  $\frac{1}{8}$  in. per foot (3 mm per .3 m) of damper width and  $\frac{1}{8}$  in. per foot (3 mm per .3 m) height with a minimum clearance of  $\frac{1}{4}$  in. (6 mm). The width and height of the opening in the floor may be up to  $1\frac{1}{2}$  in. (38 mm) greater than the width and height of the damper.

## Installing Multiple Section Assemblies

A damper assembly is not restricted to a maximum number of sections, but must not exceed the section sizes and overall sizes shown (see chart below).

The damper sections must be attached together with #10 ( $\frac{3}{4}$  in. max. [19 mm]) sheet metal screws,  $\frac{1}{4}$  in. (6 mm) diameter nuts and bolts, tack or spot welds, or  $\frac{3}{16}$  in. (48 mm) diameter steel pop rivets. Attachments must be spaced a maximum of 6 in. (152 mm) O.C. and a maximum of 2 in. (51 mm) from corners. Attachments must be made on front face and back face (air entering and air exiting side) of damper sections.

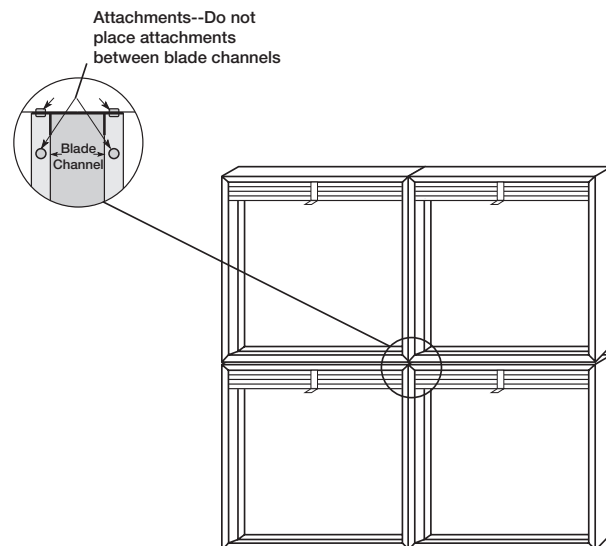

Figure 5

## Maximum Assembly Tables

When multiple sections are shipped unassembled, installer shall fasten dampers together. The table shows maximum sizes for multiple section dampers. Dampers that are two or more sections tall must be factory assembled. **Note:** All dimensions are shown in inches (W x H). \* Sizes listed refer to the damper size, not transition size.

Damper Model	Mounting	Maximum Single Section Damper Sizes*	Maximum Multi-Section Damper Sizes*
FD-310, SSFD-350	Vertical	48 X 48 (1219 mm x 1219 mm)	-
FD-150	Vertical or Horizontal	48 X 48 (1219 mm x 1219 mm)	96 x 48 (2438 mm x 1219 mm) or 74 x 74 (1880 mm x 1880 mm) or 120 x 40 (3048 mm x 1016 mm)
FD-110	Vertical or Horizontal	48 x 48 (1219 mm x 1219 mm)	96 x 48 (2438 mm x 1219 mm)
SSFD-150	Vertical	48 X 48 (1219 mm x 1219 mm)	96 X 48 (2438 mm x 1219 mm) or 120 X 40 (3048 mm x 1016 mm)
	Horizontal	36 x 36 (914 mm x 914 mm)	-
FD-350	Vertical	48 x 48 (1219 mm x 1219 mm)	-
	Horizontal	40 x 40 (1016 mm x 1016 mm)	80 x 40 (2032 mm x 1016 mm)
KFD-150	Vertical or Horizontal	36 x 16 (914 mm x 406 mm)	96 x 48 (2438 mm x 1219 mm) or 120 x 40 (3048 mm x 1016 mm)
KFD-350	Vertical	36 x 16 (914 mm x 406 mm)	-
	Horizontal	36 x 16 (914 mm x 406 mm)	80 x 40 (2032 mm x 1016 mm)
DFD-150, DFD-110	Vertical	36 x 36 (914 mm x 914 mm)	72 x 48 (1828 mm x 1219 mm) or 60 x 60 (1524 mm x 1524 mm) or 120 x 30 (3048 mm x 762 mm)
		24 x 18 (610 mm x 457 mm)	48 x 36 (1217 mm x 914 mm)
	Horizontal	30 x 30 (762 mm x 762 mm)	-
DFD-350	Vertical	36 x 36 (914 mm x 914 mm)	-
		24 x 18 (610 mm x 457 mm)	48 x 36 (1217 mm x 914 mm)
	Horizontal	30 x 30 (762 mm x 762 mm)	-
DFD-310	Vertical	36 x 36 (914 mm x 914 mm)	-
	Horizontal	30 x 30 (762 mm x 762 mm)	-
SSDFD-150, SSDFD-350	Vertical	30 x 30 (762 mm x 762 mm)	-
FD-150X	Vertical or Horizontal	48 x 48 (1219 mm x 1219 mm)	-
DFD-150X	Vertical	36 x 36 (914 mm x 914 mm)	-
	Horizontal	30 x 30 (762 mm x 762 mm)	-

## Sleeve Requirements

All fire dampers must be installed in a steel sleeve of the required gauge and length. Note that DFD-150X and FD-150X series dampers are provided with an integral sleeve. See **Table on page 9** for required minimum sleeve gauges. Maximum sleeve thickness is 10 gauge (3.5 mm). Sleeve inside dimensions must equal damper outside dimensions.

Sleeves shall extend a maximum of 6 in. (152 mm) beyond the wall or floor opening on each side. When a factory mounted access door is incorporated as a part of the sleeve, the sleeve may extend a maximum of 16 in. (406 mm) beyond the wall or floor opening on the access door side.

Fire dampers must be attached to sleeves as shown in **Figure 6**. All four sides of the damper frame must be attached to the sleeve with one row of attachments on each side of the blade channel. Attachments must be spaced a maximum of 6 in. (152 mm) O.C. and a maximum of 2 in. (51 mm) from corners. A minimum of 4 attachments (2 on each side of the blade channel) per side (16 per damper) are required. One of the methods of attachment shown below must be used:

- tack or spot welds
- #10 sheet metal screws
- ¼ in. (6 mm) bolts and nuts
- ⅜ in. (4.7 mm) steel pop rivets

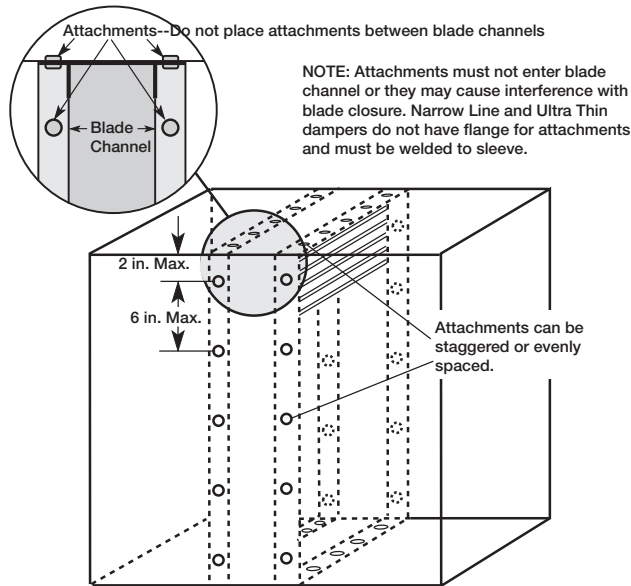

Figure 6: Field attachment of fire dampers to sleeves.

## Inserting Damper into Wall/Floor Openings

Insert the sleeved damper assembly into the prepared opening. Refer to label on outside of sleeve for the recommended location of the damper in the wall or floor (see Dimension A and Detail 1, **Figure 7**).

Special attention must be paid to ensure the following:

- 1) The  $C_L$  (centerline) of the damper frame remains within the plane of the wall or floor
- 2) The sleeve does not extend more than 6 in. (406 mm) beyond the wall or floor on each side. When a factory mounted access door is incorporated as a part of a sleeve, the sleeve may extend a maximum of 16 in. (406mm) beyond the wall or floor opening on the access door side.

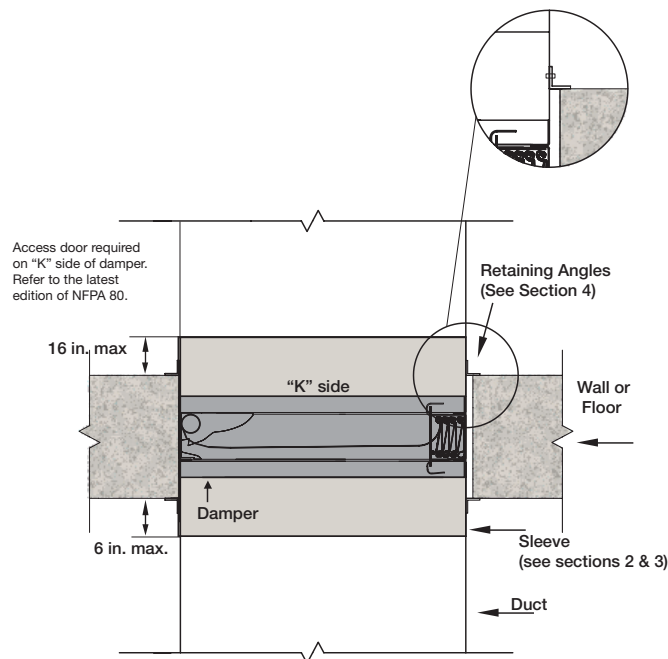

Figure 7  
Type A

Most fire dampers come without factory supplied sleeves. For field supplied sleeve, see the Field Supplied Sleeves supplement at [www.vencoproducts.com](http://www.vencoproducts.com).

## Securing the Damper/Sleeve Assembly to Wall/Floor Openings

All fire and combination fire smoke dampers may utilize the two sided angle installation method described below. 1½ hour rated fire and combination fire smoke dampers may use the single side angle installation method up to the following maximum sizes:

- Vertical mount: 80 in. W x 50. in. H (2032 mm W x 1270 mm H), 50 in. W x 80 in. H (1270 mm W x 2032 mm H), or 40 in. W x 100 in. H (1016 mm W x 2540 mm).
- Horizontal mount: 144 in. W x 96 in. H (3658 mm W x 2438 mm H)

**Retaining Angle Gauge:** Retaining angles for 1½ hour rated dampers with a width and height 48 in. (1219 mm) or less must be a minimum of 20 ga. (1 mm). Retaining angles for all 3 hour rated dampers and all dampers with a width or height greater than 48 in. (1219 mm) must be a minimum of 16 ga. (1.5 mm).

**Retaining Angle Size:** The leg of the retaining angle on the damper sleeve shall be a minimum of 1¼ in. (32 mm). The leg of the retaining angle on the wall/floor shall be long enough to cover the annular space and overlap the wall/floor by a minimum of 1 in. (25 mm).

**Retaining Angle Attachment to Sleeve:** Retaining angles must be attached to the damper using one or more of the following methods of attachment (refer to label on outside of sleeve for 'No Screw' area):

- Tack or spot welds
- #10 (¾ in. [19 mm] max.) sheet metal screws
- ¼ in. (6 mm) bolts and nuts
- ⅜ in. (5 mm) steel pop rivets

A minimum of two connections per side, top, and bottom, spaced 12 in. (305 mm) on center (O.C.) maximum are required for openings of 48 in. W x 36 in. H (1219 mm x 914 mm) and less. Dampers greater than 48 in. wide (1219 mm) or 36 in. high (914 mm) require the connections to be no more than 6 in. (152 mm) on center.

The angles must be attached to all 4 sides of the sleeve. Ensure that fasteners do not interfere with the operation of the damper. The angles need not be attached to each other at the corners.

### Retaining Angle Attachment to Wall/Floor:

**Two-Sided Angle Method:** For two-sided angle installations the retaining angles shall not be attached to the wall/floor (see Figure 8).

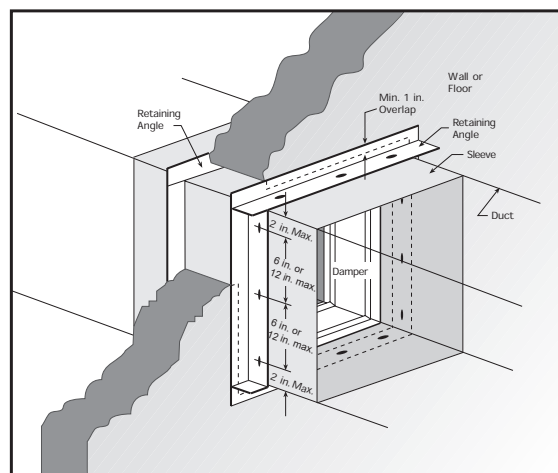

Figure 8: Two-sided angle installation method

**Single Side Angle Method:** For single side installations the retaining angles must be attached to the wall/floor (see Figures 9-12). For metal stud partitions only, the single side mounting angle may be directly attached to the metal stud prior to the installation of the drywall.

- Retaining angles must be attached to the partition using one of the methods shown below:
  - #10 screws of a length such that the screw engages the steel stud/track by ½ in. (13 mm) (steel framing).
  - #10 screws of a length such that the screw engages the wood stud by 1¾ in. (44 mm) (wood framing).
  - Steel anchors, self tapping concrete screws, or #10 masonry screws penetrating masonry or block 1¼ in. (31 mm).
- A minimum of two connections per side are required. Additional connections made at a maximum of 12 in. (305 mm) O.C. for openings of 48 in. W x 36 in. H (1219 mm x 914 mm) and less. Dampers greater than 48 in. wide (1219 mm) or 36 in. high (914 mm) require the connections to be no more than 6 in. (152 mm) O.C.

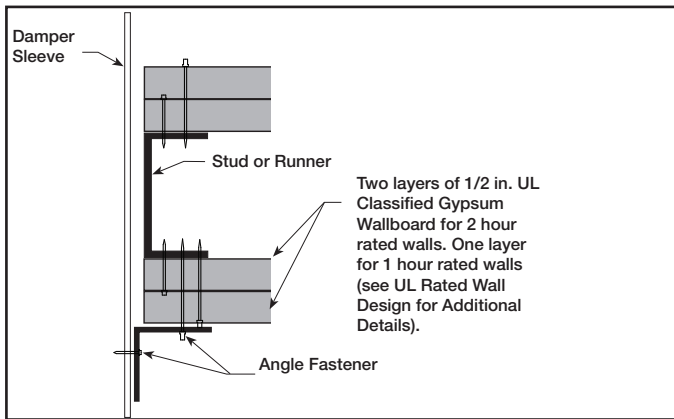

Figure 9: Single Side Angle With Steel Stud Wall Angle Over Wallboard

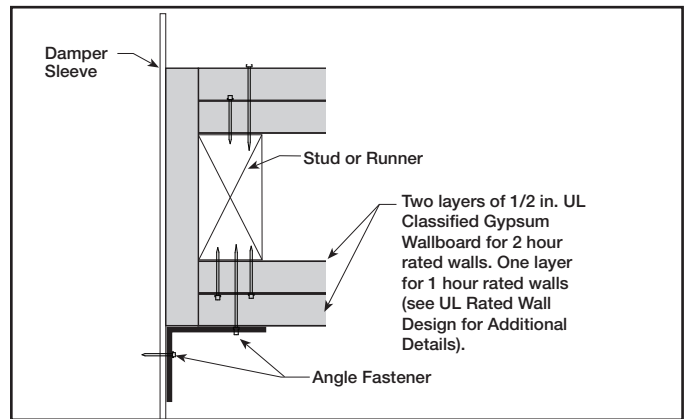

Figure 10: Single Side Angle With Wood Stud Wall

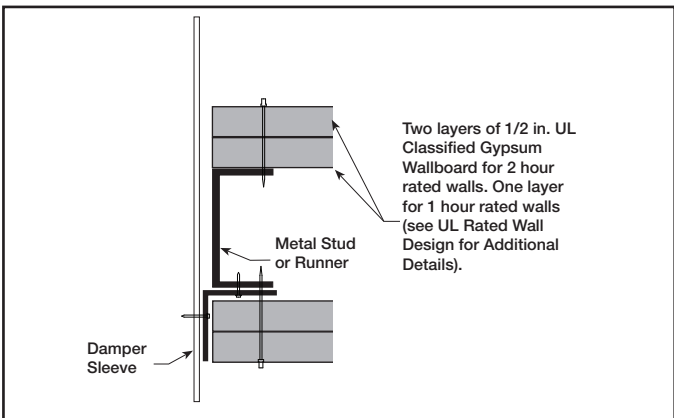

Figure 11: Single Side Angle With Steel Stud Wall Angle Under Wallboard

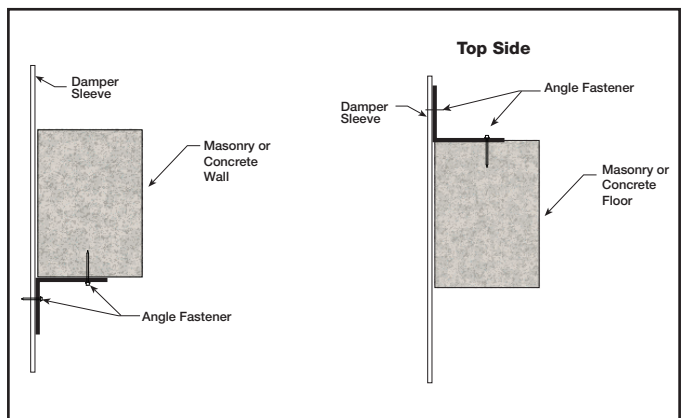

Figure 12: Single Side Angle With Masonry or Concrete Wall and Floor

## Grille Installations (Dampers up to 36 in. x 36 in. [914 mm x 914 mm])

Retaining angles used in conjunction with grille installations must be a minimum of  $\frac{5}{8}$  in. x 1 in. (15 mm x 25 mm) 16 gauge (1.5 mm) steel. Space screws a maximum of 6 in. (152 mm) O.C. and a maximum of 2 in. (51 mm) from the corners (minimum of 2 screws per side). See **Figure 13** and **Figure 14**.

**Note:** Screws used to attach grille are allowed to penetrate reversed angle leg.

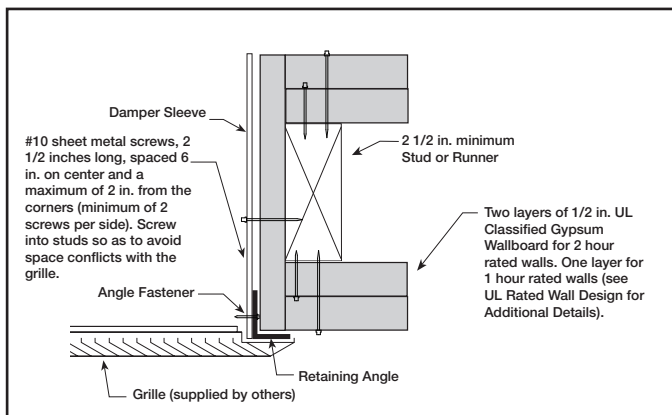

Figure 13: Wood Stud - Grille

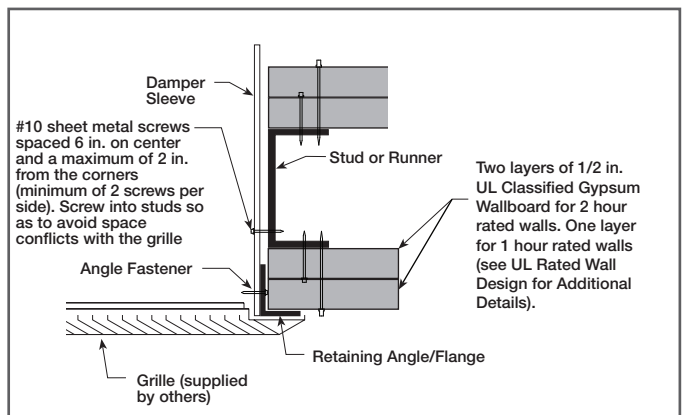

Figure 14: Metal Stud - Grille



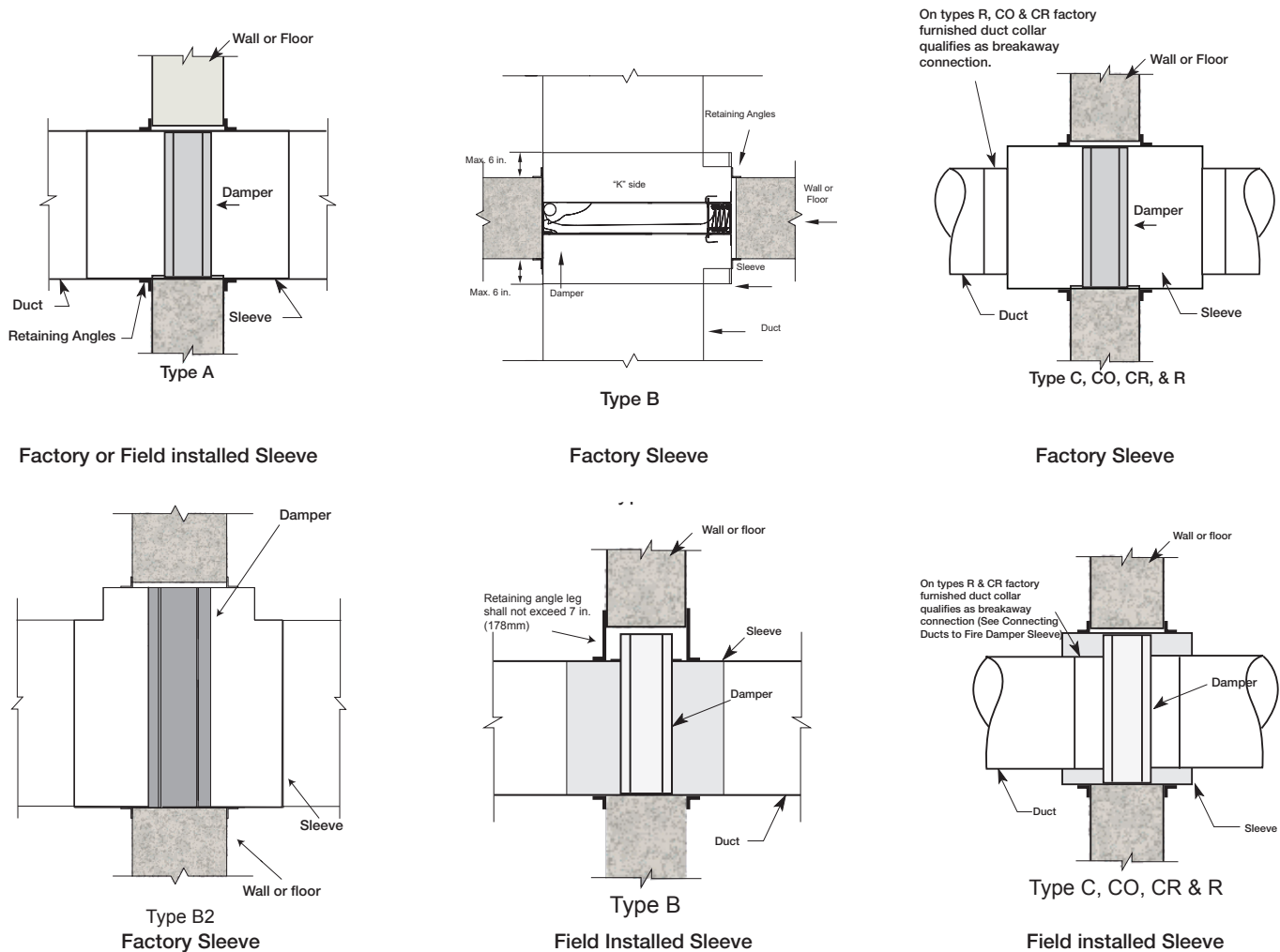

Figure 15: Damper/Sleeves with Transition

## Duct to Sleeve Connection

### Sleeve Gauge and Connection Type Requirements

The size of the damper/duct determines the required sleeve gauge and the required duct to sleeve connection (see table to the right). The sleeve thickness must also not be less than the gauge of the connecting duct. Any duct connection other than the breakaway connections described below are considered rigid.

Sleeve Gauge	Duct Dimension	Type of Duct to Sleeve Connection Permitted
14 ga. (0.075 in.) - 10 ga. (0.138 in.) [2 mm - 3.5mm]	All duct sizes	Rigid or Breakaway
16 ga. (0.060 in.) [1.5 mm]	36 in. (914 mm) max. width 24 in. (610 mm) max. height 24 in. (610 mm) diameter	Rigid or Breakaway
16 ga. (0.060 in.) [1.5 mm]	All duct sizes	Breakaway only
18 ga. (0.048 in.) [1.2 mm]	85 in. (2159 mm) wide and over	
20 ga. (0.036 in.) [0.9 mm]	55 in. - 84 in. wide (1397 mm - 2134 mm)	
22 ga. (.030 in.) [0.76 mm]	31 in. - 54 in. wide (787 mm - 1372 mm)	
24 ga. (0.024 in.) [0.6 mm]	13 in. - 30 in. wide (330 mm - 762 mm)	
26 ga. (0.018 in.) [0.46 mm]	12 in. wide and under (305 mm)	
See Breakaway Connection section for additional information. UL Standard 555 requires all ducts to terminate at fire damper sleeves.		

## Approved Breakaway Connections

All breakaway connections described below may utilize the following duct sealants: PA2084T duct sealant adhesive manufactured by Precision, DP1010 water base duct sealant manufactured by Design Polymerics, Grey Pookie, Ductmate PROseal®, or CL Ward S Seal in accordance with SMACNA recommendations.

### Transverse Joints

The transverse joints shown below are approved as breakaway connections.

- A maximum of two #10 (19 mm) sheet metal screws on each side and on the bottom may be used. The screws should be located in the center of the slip pocket and penetrate both sides of the slip pocket.
- Dampers up to 20 in. (508 mm) high may use transverse joints on the top and bottom and Drive Slip joints (see **Figure 17**) on the sides.

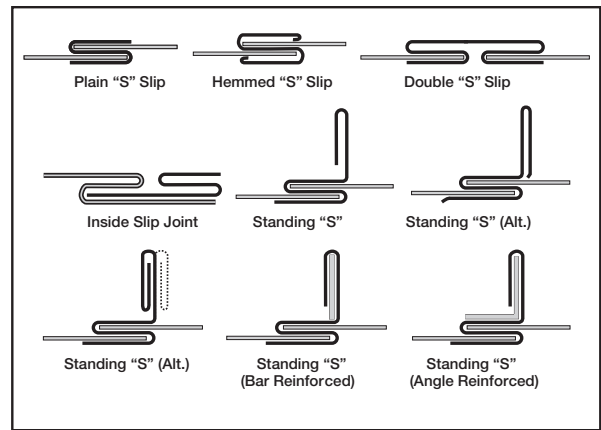

Figure 16 - Transverse Joints



Figure 17

## Round and Oval Duct Breakaway Connections

Round or flat oval ducts connected to Type R or O damper collars shall be attached with #10 (19 mm) sheet metal screws as follows:

- Ducts up to 22 in. (558 mm) wide (or dia.) and less shall have three screws.
- Ducts larger than 22 in. (558 mm) wide (or dia.) up to and including 36 in. (914 mm) wide (or dia.) shall have five screws.

Factory furnished duct collars, type R and O, are also considered breakaway (see **Figure 18**).

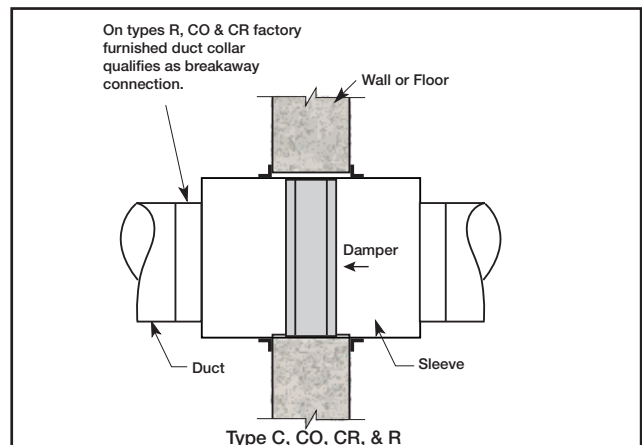

Figure 18: Type R and O Transition

## Manufactured Flanged System Breakaway Connections

Flanged connection systems manufactured by Ductmate, Durodyne, Ward, Nexus, Radiant T-35m, and MEZ are approved as breakaway connections when installed as illustrated (see **Figure 19**).

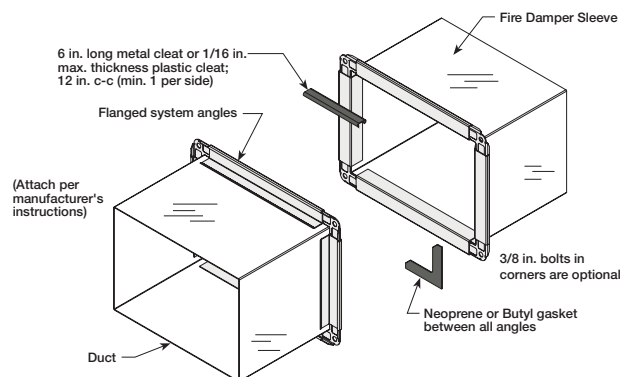
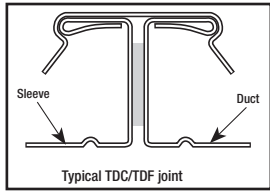

Figure 19

# Proprietary Flanged System Breakaway Connections

(TDC by Lockformer, TDF by Engle)

TDC and TDF systems are approved as breakaway connections when installed as described in the TDC or TDF addendum to the SMACNA Duct Construction Standards. Standard 6 in. (152 mm) metal clip may be used with spacing as shown in diagram (see **Figure 20 & 21**). A 3/8 in. (9.5 mm) metal bolts and nuts may be used to fasten together corner pieces (see **Figure 22**).



**Figure 20**

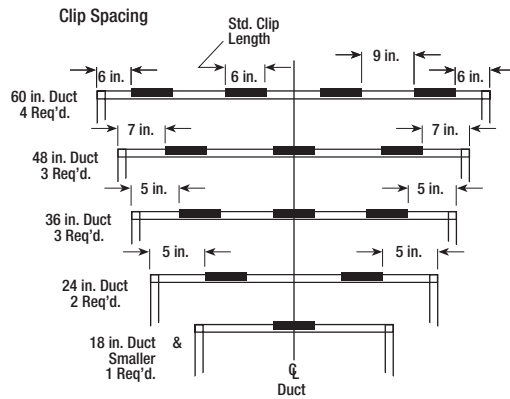

**Figure 21**

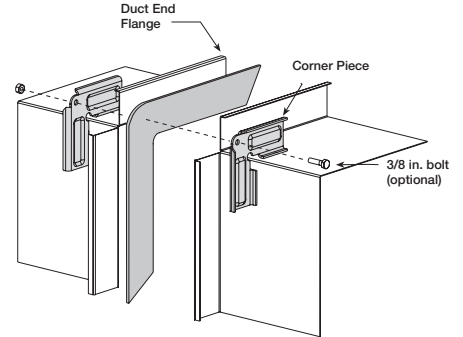

**Figure 22**

## TDC/TDF to Manufactured Flange

Flanged connection systems manufactured by Ductmate, Durodyne, Ward, Nexus, Radiant T-35m, and MEZ can be connected to TDC and TDF system as an alternate breakaway connection. This alternate connection is covered under the UL certification of the damper. See Supplement: Duct-Sleeve Connection (IOM #468502) for more information.

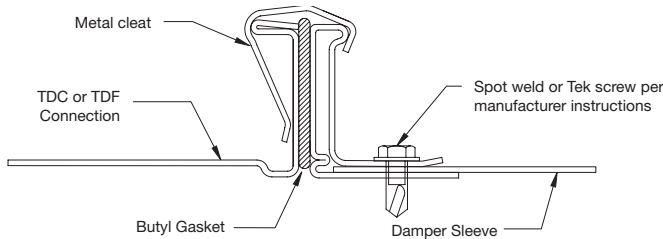

**Figure 23: Metal cleat method**

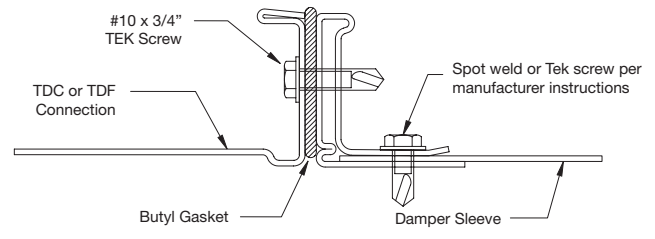
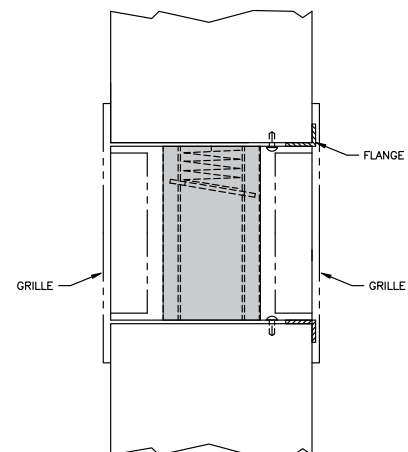

**Figure 24: Screw method**

## No Connecting Duct or Transfer Opening

Openings where duct does not attach on either side will not require a breakaway connection. Transfer openings are typical of a non-ducted installation (see **Figure 25**).

- Sleeve may end flush with the rated wall/floor on both sides
- Refer to Securing the Damper/Sleeve Assembly to Wall/ Floor Openings for securing retaining angles to the sleeve.



**Figure 25: Transfer opening or no connecting duct**

## Damper Commissioning and Periodic Testing

---

The International Fire Code (IFC) requires fire dampers to be maintained in accordance with NFPA standard 80 and smoke dampers to be maintained in accordance with NFPA standard 105. NFPA 80 and 105 define the frequency and method for periodically testing life safety dampers.

NFPA 80 & 105 do not require heat to be applied to a damper's fusible link or thermostat during periodic testing. Electric or pneumatic actuated dampers are required to be tested by temporarily removing electrical or pneumatic power from the actuator to ensure the damper fully closes and then fully opens once power is restored. Mechanical and gravity operated dampers utilizing a fusible link are required to be tested by removing the fusible link and allowing the damper to fully close and then manually reopening the damper re-installing the fusible link.

Greenheck's life safety dampers shall not be tested by applying heat with uncontrollable heat sources (i.e. heat guns, torches, etc.) as this can permanently damage the thermostat or other parts of the damper.

## Damper Maintenance

---

Dampers do not typically require maintenance as long as they are kept dry and clean. If cleaning is necessary, use mild detergents or solvents. If lubrication is desired for components such as axle bearings, jackshaft bearings and jamb seals, do not use oil-based lubricants or any other lubricants that attract contaminants such as dust.

## Damper Troubleshooting

---

The following is a possible cause and correction list for common concerns with the dampers.

Symptom	Possible Cause	Corrective Action
Damper does not fully open and/or close	Frame is 'racked' causing blades to bind on jamb seals	Adjust frame such that it is square and plumb
	Screws in damper linkage	Damper installed too far into wall. Move out to line as designated on damper label
	Contaminants on damper	Clean with a non-oil based solvent (see Damper Maintenance)
Link separated	Heat	Replace link

## Our Commitment

---

*As a result of our commitment to continuous improvement, Venco reserves the right to change specifications without notice.*

