

Installation, Operation and Maintenance Manual

Please read and save these instructions for future reference. Read carefully before attempting to assemble, install, operate or maintain the product described. Protect yourself and others by observing all safety information. Failure to comply with these instructions will result in voiding of the product warranty and may result in personal injury and/or property damage.



Table of Contents

Installation Guidelines	2
Installation Details	2-5
Fasteners/Anchors	6
Maintenance	7
Troubleshooting	8

Receiving and Handling

Upon receiving dampers, check for both obvious and hidden damage. If damage is found, record all necessary information on the bill of lading and file a claim with the final carrier. Check to be sure that all parts of the shipment, including accessories, are accounted for.

Dampers must be kept dry and clean. Indoor storage and protection from dirt, dust and the weather is highly recommended. Do not store at temperatures in excess of 100°F (38°C).

Safety Warning

Improper installation, adjustment, alteration, service or maintenance can cause property damage, injury or death. Read the installation, operating, and maintenance instructions thoroughly before installing or servicing this equipment.

Storage of Dampers Prior to Installation

The basic intent of proper storage of heavy duty/ industrial tornado damper is to prevent physical damage, material corrosion, and deterioration of organic material.

- 1) Visually inspect the damper for damage. Store indoors, protected for sunlight, moisture, and flooding. Protect damper from debris and dirt accumulation.
- 2) Dampers may be stacked and stored horizontally if wood or equivalent spacers are placed between flanges to protect finish. Do NOT store with axles vertical. Place dampers on pallets or supports to allow air circulation. Do NOT store with damper directly on concrete or ground.
- 3) Consult manufacturer if storage time exceeds two years.

This manual is the property of the owner and is required for future maintenance. Please leave it with the owner when the job is complete.

Installation Guidelines- Failure to follow instructions will void all warranties

The basic intent of a proper installation is to secure the heavy duty/industrial blast damper into the opening in such a manner as to prevent distortion and disruption of damper operation. The following items will aid in completing the damper installation in a timely and effective manner.

- 1) Dampers are supplied standard without mounting holes. Drill or punch as required. Use appropriate gasketing between mating flanges. Closed cell sponge rubber, solid rubber, maximum 60 durometer, or fiberglass drop warp tape is recommended. If damper is replacing existing damper, clean mating surfaces prior to installing new damper.
- 2) Damper blades remain within the frame depth.
- 3) The HBS-330 & 430 is install the same direction as flow. The HBS-331 & 431 is install opposite direction as normal flow. Damper blade centerline **MUST** be horizontal. Consult Greenheck for modifications if damper is to be mounted with blade centerlines vertical.
- 4) Isolate damper from high vibratory loadings.
- 5) Damper must be installed square and free of twist or other misalignment. Out of square, racked, twisted or misaligned installations can cause the damper to not operate properly.
- 6) Damper assemblies are not designed to carry any additional load from adjacent ducts or plenums. Consult factory for design assistance if needed.

Do's

- 1) Use damper lifting lugs as provided.
- 2) Install all mounting bolts before tightening. Tighten in even and staggered pattern to evenly compress flange gasketing.
- 3) Mating flange must be flat and in the same plane.
- 4) Verify that damper does not strike mating ductwork or internal ductwork reinforcing when blade is in the open position.
- 5) Provide expansion joints upstream/downstream for angled ductwork so damper is not subjected to thermal/wind load forces off the centerline of damper.

Dont's

- 1) Do not lift damper with chain/strap with blade propped open and with chain/strap through frame as this could damage blade seal.
- 2) Do not use linkage or axles as lifting point.
- 3) Do not use prybar to match frame holes to mating ductwork as frame can be warped or pulled out of square by excessive force.
- 4) Do not tighten mounting bolts by starting at one point and "walking" around the damper as uneven flange compression can result.

Installation Details

Maximum Size and Installation Information

Models HBS-330 and HBS-331 must be installed in accordance with the installation shown herein. Both models are qualified for installation within concrete/masonry or ductwork. This model is structurally designed to withstand a blast load of up to 5.77 psi (160 in. wg) at 29.69 psi-msec.

Models HBS-430 and HBS-431 must be installed in accordance with the installation shown herein. Both models are qualified for installation within concrete/masonry or ductwork. This model is structurally designed to withstand a blast load of up to 15 psi (451 in. wg) at 100 psi-msec.

Mounting in Ductwork

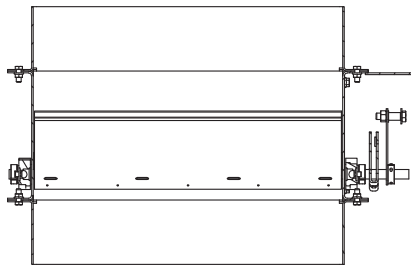

Horizontal Section View

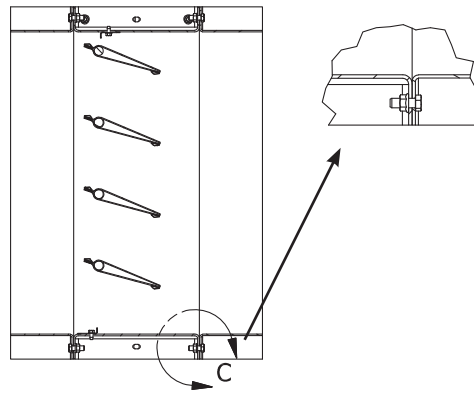

Typical Vertical Section View

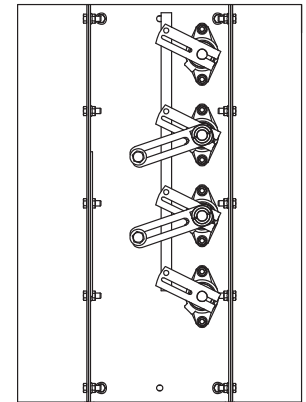

Typical End View

HBS Duct Mount	
Item #	Part Description
1	Duct section
2	HBS assembly
3	Flange to duct bolts

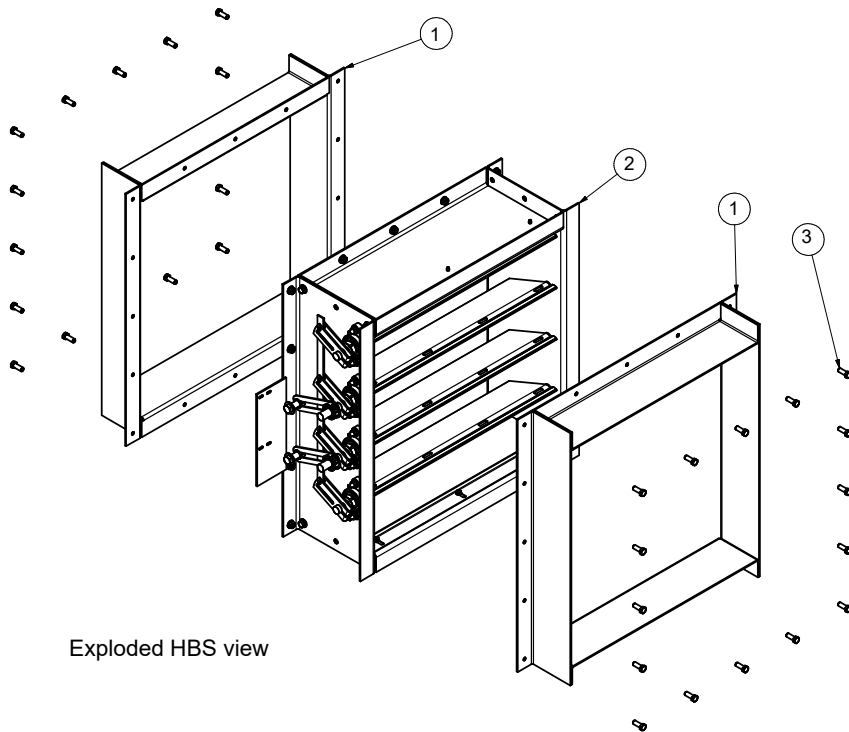

Exploded HBS view

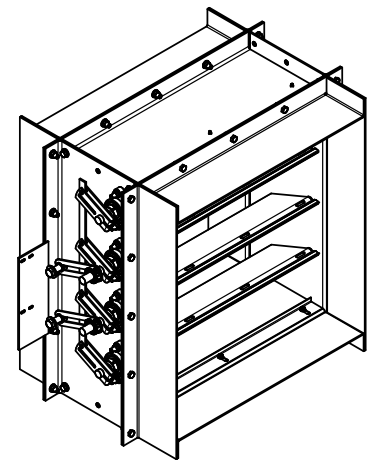

Assembled HBS view

Notes:

- 1) Maximum blast loading for the HBS-330 and 331 is 5.77 psi @ 29.69 psi-msec. Maximum blast loading for the HBS-430 and 431 is 15 psi @ 100 psi-msec.
- 2) The recommended fastener is a Grade 8 3/8 in. diameter bolt.
- 3) It is assumed that the ductwork is designed to withstand blast loading independent of damper.

Mounting Within the Wall

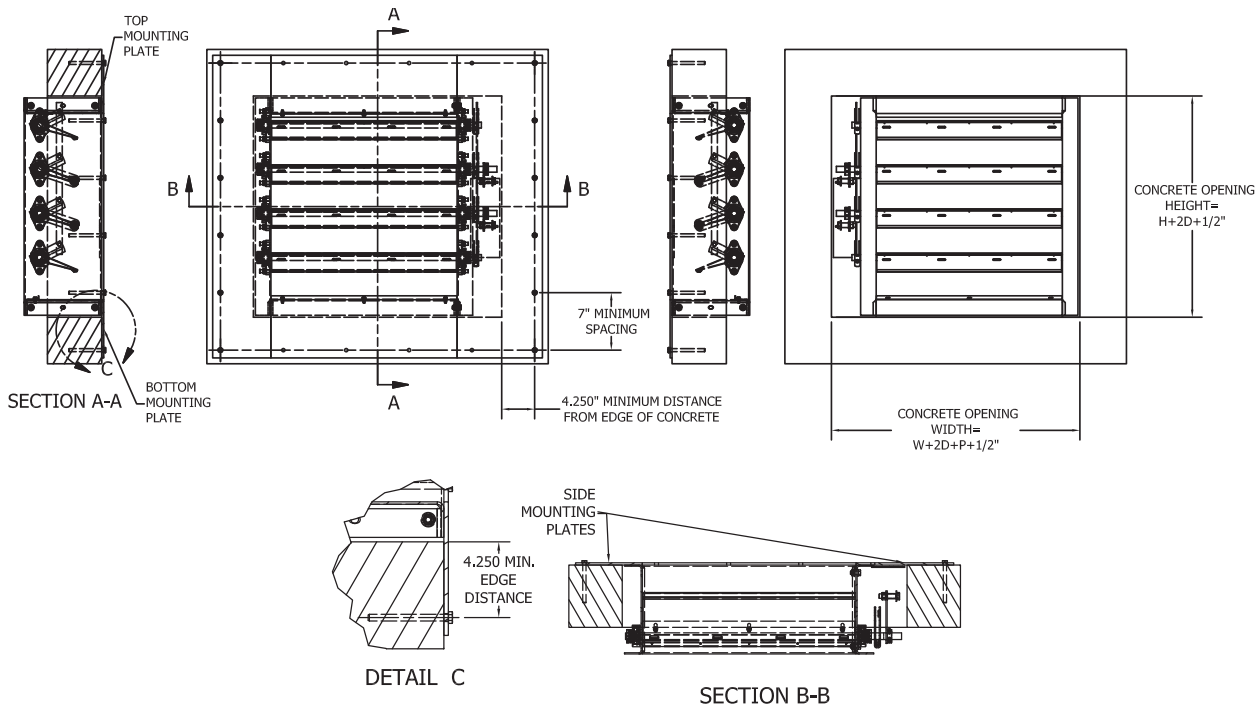

HBS Interior Wall Mount	
Item #	Part Description
1	Wall section
2	HBS assembly
3	Anchor plate top/bottom
4	Anchor plate side
5	Anchor plate to wall mounting anchor
6	Flange to anchor plate bolt

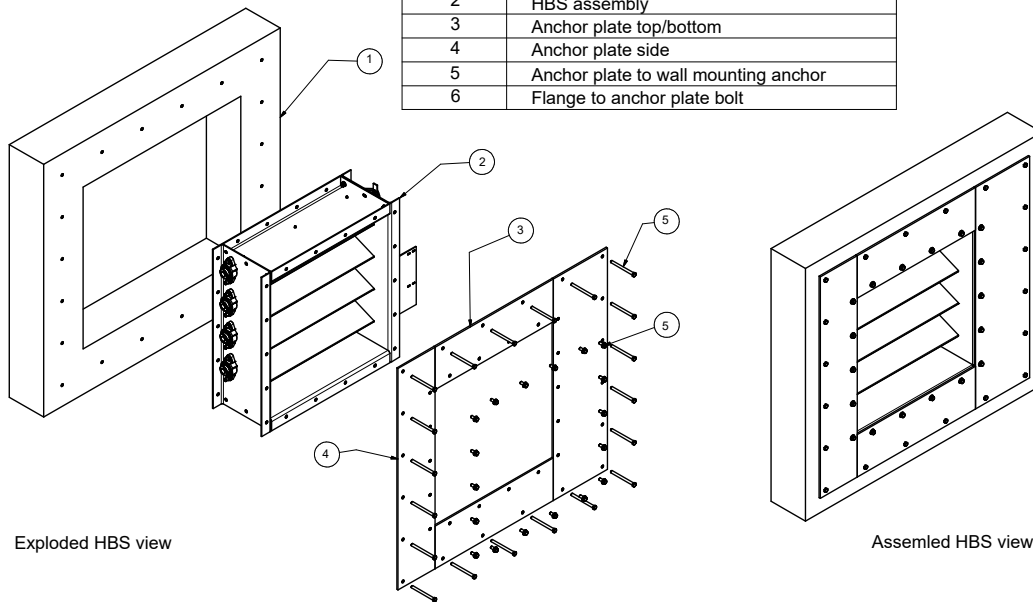

Notes:

- 1) Maximum blast loading for the HBS-330 and 331 is 5.77 psi @ 29.69 psi-msec. Maximum blast loading for the HBS-430 and 431 is 15 psi @ 100 psi-msec.
- 2) Concrete must have a compressive strength of 4,000 psi or better.
- 3) Concrete must be a minimum of 7 in. thick (normal weight).
- 4) The recommended anchor is a $\frac{3}{8}$ in. diameter Hilti HUS-EZ (or equivalent).
- 5) Minimum anchor embedment is $3\frac{1}{4}$ in.
- 6) Anchor mounting plates must be $\frac{1}{4}$ in. thick minimum, carbon steel (or equivalent).
- 7) 'P' dimension varies depending on size and velocity. Consult factory if needed for wall opening size.

Mounting to the Wall

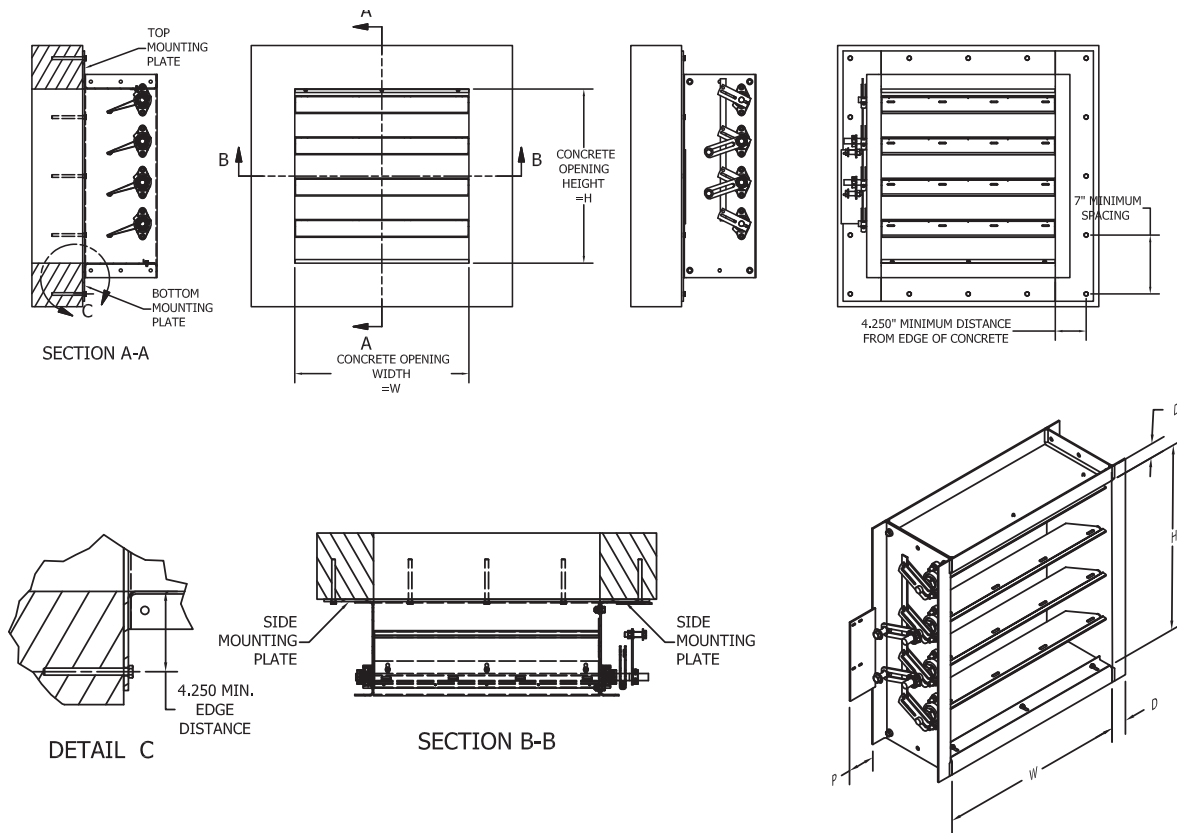

HBS Exterior Wall Mount	
Item #	Part Description
1	Wall section
2	HBS assembly
3	Anchor plate top/bottom
4	Anchor plate side
5	Anchor plate to wall mounting anchor
6	Flange to anchor plate bolt

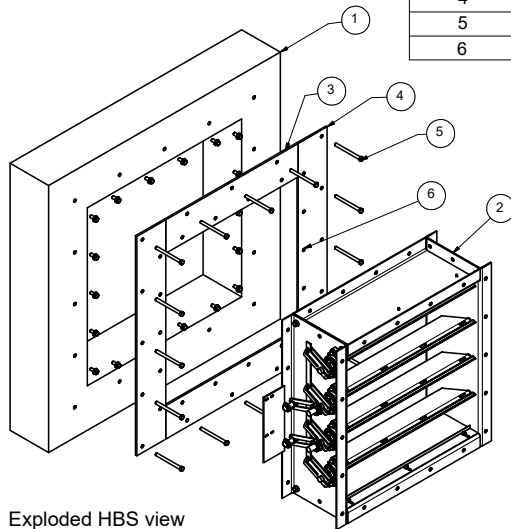

Exploded HBS view

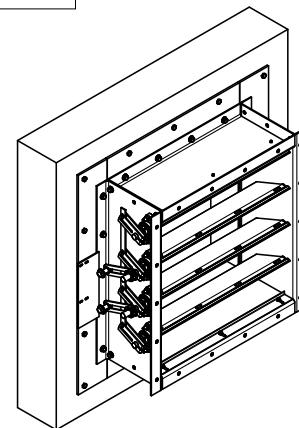

Assembled HBS view

Notes:

- 1) Maximum blast loading for the HBS-330 and 331 is 5.77 psi @ 29.69 psi-msec. Maximum blast loading for the HBS-430 and 431 is 15 psi @ 100 psi-msec.
- 2) Concrete must have a compressive strength of 4,000 psi or better.
- 3) Concrete must be a minimum of 7 in. thick (normal weight).
- 4) The recommended anchor is a $\frac{3}{8}$ in. diameter Hilti HUS-EZ (or equivalent).
- 5) Minimum anchor embedment is $\frac{3}{4}$ in.
- 6) Anchor mounting plates must be $\frac{1}{4}$ in. thick minimum, carbon steel (or equivalent).

Fastener/Anchor

Mounting Substrate	Description	Quantity	Minimum Embed	Minimum Edge Distance	Minimum Spacing
Concrete/masonry	3/8 in. diameter HILTI HUS-EZ (or equal)	Varies	3 1/4 in.	4 1/4 in.	7 in.
Ductwork	3/8 in. nominal diameter Grade 8 bolt with nut	Varies	N/A	N/A	N/A

General notes

1. It shall be the responsibility of the permit holder to verify the structural integrity of the existing structure to support the loads superimposed by the dampers.
2. Concrete to be a minimum of 7 in. thick (normal weight) with a compressive strength of 4,000 psi or better.
3. Anchor mounting plates must be 1/4 in. thick with yield strength of 30,000 psi minimum.

Maintenance

Greenheck's dampers are designed to be trouble free and hassle free under normal operation. The following annual damper maintenance suggestions will help to insure proper damper operation and increase the life expectancy of the damper.

Foreign Matter

Over the course of time, dirt and grime may collect on damper surfaces. The damper surfaces should be cleaned to prevent hindrance to airflow.

Moving Parts

Make sure that parts such as linkage, bearings, blades, etc. that are intended to move freely, can do so. Lubricating these components can prevent possible rusting and unnecessary friction increase. Use only a molybdenum spray oil or similar graphite based oil on sleeve bearings as regular lubricating oil will attract dirt.

Bearings. Synthetic, oil impregnated, carbon sleeve, and ball bearings (without grease fittings) do not require lubrication. Ball bearings with grease fittings should be lubricated as follows:

Maximum Duct Temperature °F (°C)	Lubricant	Minimum Frequency
250° (121°)	NLG1 Grade 2 lithium 12-hydrostearate grease	twice a year
600°(316°)	Hi temperature synthetic, Mobillith SHC100 or equal	four times a year

Closure

Remove foreign materials that may be interfering with blade closure or effective sealing of the blades with each other or with the frame.

Blade Seals. Inspect annually. Replacement is recommended after 5 years to reduce the potential of leakage on HBTR series. Damper serial number required when ordering replacement seal.

Axle seals. Inspect and adjust as necessary.

Operation

While operating the damper through its full cycle, check to see that the blades open and close properly. If there is a problem, check for loose linkage, especially at the actuator. Tighten the linkage where required.

Troubleshooting

The following is a cause and correction list for common concerns with the damper:

Problem	Possible Cause	Solution
Damper does not move	Damper linkage failed	Inspect damper for failed clevis pins, clevises, or crankarms and replace as necessary.
	Obstruction in damper linkage or inside duct	Inspect for projecting mounting bolts, debris inside damper and remove.
Damper attempts to move but, does not open fully	Obstruction in damper linkage or inside duct	Inspect for projecting mounting bolts, debris inside damper and remove.
	Damper linkage modified in the field	Readjust linkage so blade rotates fully open and closed.
	Linkage pivots failed	Replace linkage bars, clevises, and pins as required.
High noise level	Very high velocity/flow	Reduce flow through damper.
	Damper not closing fully	Readjust actuator or drive linkage to fully close damper.

DATE

NOTES

Our Commitment

As a result of our commitment to continuous improvement, Venco reserves the right to change specifications without notice.



Phone: 1.833.881.0565 • Fax: 715.355.2399 • E-mail: info@vencoproducts.com • Website: www.vencoproducts.com