

## Installation, Operation and Maintenance Manual

Please read and save these instructions for future reference. Read carefully before attempting to assemble, install, operate or maintain the product described. Protect yourself and others by observing all safety information. Failure to comply with these instructions will result in voiding of the product warranty and may result in personal injury and/or property damage.

**⚠ IMPORTANT:** Overhead ceiling fans must be installed with the supplied CAT-5e communication cable or shielded CAT-5e (by others) that complies with the following specifications. Cable must be twisted pair, shielded 26 AWG CAT-5e cable with a drain wire and must be compliant with ISO 11801. Cable must use shielded RJ45 connectors with a soldered drain and wiring configuration must follow EIA/TIA T568B wiring pinout. Individual CAT-5e cable lengths must not exceed 200 ft. in order to prevent network communication issues.



Model VCFC overhead ceiling fans are ideal for providing year-round comfort in air circulation and destratification applications. Designed for commercial spaces with low to medium height ceilings, model VCFC provides quiet, comfortable air movement that maximizes building efficiency by reducing load on the HVAC system. The VCFC's light-weight direct drive motor and compact design also result in effortless installation, making the VCFC a smart choice for any space.

### Required Tools

The following tools will be required to complete the installation of every VCFC fan. Additional tools may be required depending on the application and installation location of the fan.

- Socket Wrench with 5/16 in. and 7/16 in. Sockets
- 5/16 in. and 7/16 in. Wrenches
- Torque Wrench (up to 100 in·lbf)
- #2 Phillips Screwdriver
- 1/8 in. Slotted Screwdriver
- 5/64 in. Hex Key
- Magnetic Level
- Wire Strippers

**NOTE:** Model VCFC fan components can weigh 20 lbs. or greater depending upon the fan size and accessories that are provided. A suitable means for lifting the weight of the fan to the mounting point, such as a ladder or scissor lift, should be used for all VCFC fan installations.

# Table of Contents

## General

Required Tools . . . . .	1
General Safety Information . . . . .	2-4
Receiving . . . . .	4
Unpacking . . . . .	4
Storage . . . . .	4
Inspection and Maintenance During Storage . . . . .	4
Removing from Storage . . . . .	4
Fan Components . . . . .	5
Pre-Installation Checks . . . . .	6
Minimum Spacing Requirements . . . . .	7

## Mechanical Installation

Mounting Installation . . . . .	7-8
Fan-Rated Junction Box . . . . .	7-8
Alternate Structure Mounting . . . . .	8
Motor/Hub to Downtube Installation . . . . .	9-10
Safety Retention Cable Installation . . . . .	11
Airfoil Blade and Winglet Installation . . . . .	12
Hub Plate Installation . . . . .	13

## Electrical Installation

Fire System Integration (Optional) . . . . .	13
Power Wiring . . . . .	14
Communication Wiring . . . . .	15-16
With Pre-Built CAT-5e Cable . . . . .	15
With Optional 1,000 ft. Bulk Spool of CAT-5e Cable . . . . .	16
Fan Networking . . . . .	17-18
First Fan . . . . .	17
All Remaining Fans . . . . .	17-18

## Operation and Maintenance

Pre-Start-Up Checks . . . . .	19
Fan Operation . . . . .	19
Fan Inspection . . . . .	19
Fan Maintenance . . . . .	20

## Troubleshooting

Fan Balancing (Optional) . . . . .	20
General Troubleshooting . . . . .	21
Controls Troubleshooting . . . . .	21-22
Fan Troubleshooting . . . . .	23-25

## Reference

Fault Code Causes and Possible Solutions . . . . .	26
Modbus Register List . . . . .	27
Maintenance Log . . . . .	28

## General Safety Information

**IMPORTANT:** To reduce the risk of fire, electric shock or injury to persons, Model VCFC fans must be installed with a mount assembly, motor assembly, and airfoils that are marked (on their cartons) to indicate suitability with this model. Other mounts, motors, and airfoils cannot be substituted.

Only qualified personnel should install this fan. Personnel should have a clear understanding of these instructions and should be aware of general safety precautions. Improper installation can result in electric shock, possible injury due to coming in contact with moving parts, as well as other potential hazards. Other considerations may be required if high winds or seismic activity are present. If more information is needed, contact a licensed professional engineer before moving forward.

1. Follow all local electrical and safety codes, as well as the National Electrical Code (NEC) and the National Fire Protection Agency (NFPA), where applicable. Follow the Canadian Electric Code (CEC) in Canada.
2. The rotation of the impeller is critical. It must be free to rotate without striking or rubbing any stationary objects.
3. Motor must be securely and adequately grounded.
4. Do not allow the power cable to kink or come in contact with oil, grease, hot surfaces or chemicals. Replace cord immediately if damaged.
5. Verify that the power source is compatible with the equipment.

<b>WARNING</b>
To reduce the risk of fire, electric shock, or injury to persons, observe the following: <ol style="list-style-type: none"> <li>1. Use this unit only in the manner intended by the manufacturer. If you have questions, contact the manufacturer.</li> <li>2. Before servicing or cleaning unit, switch power off at service panel and lock the service disconnecting means to prevent power from being switched on accidentally. When the service disconnecting means cannot be locked, securely fasten a prominent warning device, such as a tag, to the service panel.</li> </ol>
<b>WARNING</b>
To reduce the risk of fire, electric shock, or injury to persons, observe the following: <ol style="list-style-type: none"> <li>1. Installation work and electrical wiring must be done by qualified person(s) in accordance with all applicable codes and standards, including fire rated construction.</li> <li>2. When cutting or drilling into wall or ceiling, do not damage electrical wiring and other hidden utilities.</li> </ol>
<b>WARNING</b>
To reduce the risk of fire or electric shock, do not use this fan with any sold-state speed control devices.
<b>WARNING</b>
This appliance can be used by children aged from 8 years and above and persons with reduced physical, sensory or mental capabilities or lack of experience and knowledge if they have been given supervision or instruction concerning use of the appliance in a safe way and understand the hazards involved. Children shall not play with the appliance. Cleaning and user maintenance shall not be made by children without supervision.
<b>DANGER</b>
Always disconnect, lock and tag power source before installing or servicing. Failure to disconnect power source can result in fire, shock or serious injury.
<b>CAUTION</b>
When servicing the fan, motor may be hot enough to cause pain or injury. Allow motor to cool before servicing.
<b>CAUTION</b>
Precaution should be taken in explosive atmospheres.
<b>WARNING</b>
To reduce the risk of personal injury, do not bend the blade brackets when installing the brackets, balancing the blades, or cleaning the fan. Do not insert foreign objects in between rotating fan blades.

<b>WARNING</b>
To reduce the risk of fire, electric shock, or personal injury, mount directly to a structural framing member or to an outlet box marked "Acceptable for fan support of 15.9 kg (35 lbs.) or less." For outlet box mounting, use mounting screws provided with the outlet box.
<b>AVERTISSEMENT</b>
Pour réduire le risque d'incendie, de choc électrique ou de blessure corporelle, respecter ce qui suit : <ol style="list-style-type: none"> <li>1. Utiliser cet appareil exclusivement comme prévu par le fabricant. En cas de questions, communiquer avec le fabricant.</li> <li>2. Avant tout entretien ou nettoyage de l'appareil, couper l'alimentation sur le tableau de commande et verrouiller le dispositif de sectionnement pour empêcher toute mise sous tension accidentelle. Si le dispositif de sectionnement ne peut pas être verrouillé, attacher un moyen de mise en garde bien visible, tel qu'un panneau, au tableau de commande.</li> </ol>
<b>AVERTISSEMENT</b>
Pour réduire le risque d'incendie, de choc électrique ou de blessure corporelle, respecter ce qui suit : <ol style="list-style-type: none"> <li>1. La pose et le câblage électrique doivent être effectués par des personnes qualifiées en conformité avec les codes et normes en vigueur, y compris pour la résistance au feu du bâtiment.</li> <li>2. Lors de la découpe ou du perçage de murs ou plafonds, ne pas endommager les câbles électriques et autres conduites masquées.</li> </ol>
<b>AVERTISSEMENT</b>
Pour réduire le risque d'incendie ou de choc électrique, ne pas utiliser ce ventilateur avec un quelconque dispositif de régulation de vitesse à semi-conducteurs.
<b>AVERTISSEMENT</b>
Cet appareil peut être utilisé par des enfants âgés de 8 ans et plus et par des personnes aux capacités physiques, sensorielles ou mentales réduites ou qui manquent d'expérience et de connaissances s'ils sont surveillés ou ont reçu des instructions concernant l'utilisation sécuritaire de l'appareil et comprennent les risques encourus. Les enfants ne doivent pas jouer avec l'appareil. Le nettoyage et l'entretien par l'utilisateur ne doivent pas être effectués par des enfants sans surveillance.
<b>DANGER</b>
Pour écarter les risques d'incendie, de choc électrique ou de blessure grave, veiller à toujours débrancher, verrouiller et étiqueter la source de courant avant l'installation ou l'entretien.

**ATTENTION**

Lors de toute intervention sur la soufflante, le moteur peut être suffisamment chaud pour provoquer une douleur voire une blessure. Laisser le moteur refroidir avant toute maintenance.

**ATTENTION**

Faire preuve de précaution dans les atmosphères explosives.

**AVERTISSEMENT**

Afin de réduire les risques de blessure, ne pas plier les supports de pale lors de l'installation des supports, de l'équilibrage des pales ou du nettoyage du ventilateur. Ne pas insérer de corps étranger entre les pales en rotation du ventilateur.

**AVERTISSEMENT**

Afin de réduire les risques d'incendie, de décharge électrique ou de blessure, monter directement sur un élément structural ou sur une boîte de sortie indiquant la mention : « Acceptable pour un support de ventilateur de 15,9 kg (35 lb) ou moins ». En ce qui concerne le montage de la boîte de sortie, utiliser les vis de montage fournies avec la boîte de sortie.

## Receiving, Unpacking, and Storage

### Receiving

Upon receiving the product, check to ensure all items are accounted for by referencing the delivery receipt or packing list. Inspect each crate or carton for shipping damage before accepting delivery. Alert the carrier of any damage detected. The customer will note damage (or shortage of items) on the delivery receipt and all copies of the bill of lading which is countersigned by the delivering carrier. If damaged, contact your local representative immediately. Any physical damage to the unit after acceptance is not the responsibility of the manufacturer.

### Unpacking

Verify that all required parts and the correct quantity of each item have been received using the component list on pages 5. If any items are missing, report shortages to your local representative to arrange for obtaining missing parts. Sometimes it is not possible that all items for the unit be shipped together due to availability of transportation and truck space. Confirmation of shipment(s) must be limited to only items on the bill of lading.

### Storage

Fans are protected against damage during shipment. If the unit cannot be installed and operated immediately, precautions need to be taken to prevent deterioration of the unit during storage. The user assumes responsibility of the fan and accessories while in storage. The manufacturer will not be responsible for damage during storage. These suggestions are provided solely as a convenience to the user.

**Indoor** - The ideal environment for the storage of fans and accessories is indoors, above grade, in a low humidity atmosphere that is sealed to prevent the entry of blowing dust, rain or snow. Temperatures should be evenly maintained between 30° to 110°F (-1° to 43°C). Wide temperature swings may cause condensation and “sweating” of metal parts. All accessories must be stored indoors in a clean, dry atmosphere.

Remove any accumulations of dirt, water, ice or snow and wipe dry before moving to indoor storage. To avoid “sweating” of metal parts, allow cold parts to reach room temperature. To dry parts and packages, use a portable electric heater to get rid of any moisture build up. Leave coverings loose to permit air circulation and to allow for periodic inspection.

The unit should be stored at least 3-1/2 in. (89 mm) off the floor on wooden blocks covered with moisture proof paper or polyethylene sheathing. Aisles between parts and along all walls should be provided to permit air circulation and space for inspection.

### Inspection and Maintenance During Storage

While in storage, inspect fans once per month. Keep a record of inspection and maintenance performed.

If moisture or dirt accumulations are found on parts, the source should be located and eliminated. If paint deterioration begins, consideration should be given to touch-up or repainting. Fans with special coatings may require special techniques for touch-up or repair.

Machined parts coated with rust preventive should be restored to good condition promptly if signs of rust occur. Immediately remove the original rust preventive coating with petroleum solvent and clean with lint free cloths. Polish any remaining rust from surface with crocus cloth or fine emery paper and oil. Do not destroy the continuity of the surfaces. Thoroughly wipe clean with Tectyll® 506 (Ashland Inc.) or the equivalent. For hard to reach internal surfaces or for occasional use, consider using Tectyll® 511M Rust Preventive, WD-40® or the equivalent.

### Removing from Storage

As fans are removed from storage to be installed in their final location, they should be protected and maintained in a similar fashion until the fan equipment goes into operation.

# Fan Components

Verify that all of the following parts and hardware have been received prior to beginning installation. Contact your local representative or the manufacturer if replacement parts are required.

**NOTE:** Additional parts (provided by others) may be required to complete the fan installation, including additional wiring, a fan-rated junction box, and hardware for connecting the fan mount to the building structure.

**NOTE:** Hardware quantities listed below indicate what is required to complete installation. Hardware kits may include extra fasteners as a convenience.

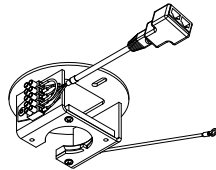

**Universal Mount (1)**

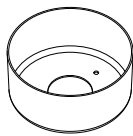

**Mount Cover (1)**

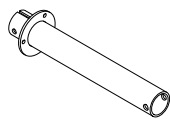

**Downtube (1)**

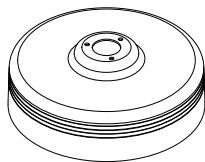

**Upper Motor Cover (1)**

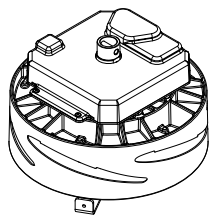

**Motor/Hub Assembly (1)**

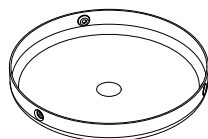

**Hub Plate (1)**

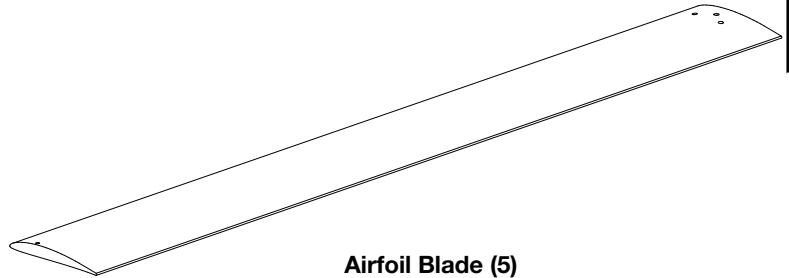

**Airfoil Blade (5)**



**Winglet (5)**

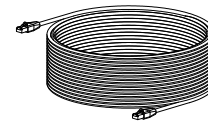

**Shielded CAT-5e Control Cable (1)**

<b>Mounting Ball Hardware Kit Bag # 918029</b>
Mounting Ball (1)
Mounting Ball Pin (1)
5/64 in. Hex Key (1)
<b>General Hardware Kit Bag # 918341</b>
#10-24 x 1.5 in. Bolt (1)
#10-24 Nylon Locknut (1)
M4x10 Machine Screw (8)
Electrical Lever Connector (3)
U-Bolt Steel Cable Clamp (1)
Upper Safety Retention Cable (1)
<b>Airfoil Blade and Winglet Hardware Kit Bag # 918342</b>
M4x10 Machine Screw (5)
#10-24 x 1 in. Bolt with Thread Locker (15)
Airfoil Washer Plate (5)
<b>Fan Balancing Kit Bag # 918439</b>
Clip-on Balance Weight (8)
Permanent Balance Weight (6)

## Pre-Installation Checks

**IMPORTANT:** Consult all applicable national, state and local codes to ensure that all necessary code requirements are met. It is the sole responsibility of the installer to ensure compliance with applicable codes.

Prior to installing the fan, perform each of the following checks:

1. Verify that fan components are undamaged. Do not install or operate any damaged fan components, fans, or fan accessories. Failure to comply with this instruction may result in property damage, personal injury and/or death.
2. Verify that the fan is to be installed in a location where the airfoils will be a minimum of 7 ft. above the finished floor with a minimum of 3 ft. of clearance to any obstructions.
3. Verify that the fan is to be installed in a location where the center of the fan is a minimum of 1.5 fan diameters away from building walls and corners.
4. For best performance, the fan must be installed with a two fan diameter minimum clearance to radiant heaters and HVAC system discharges or intakes.
5. Check that the fan will not be mounted in a location near overhead doors or other building openings where gusts of wind may occur. Fan should not be installed or operated in locations where wind is present.
6. Check to see if the intended placement of the fan is directly below any building lights or skylights. If possible, avoid installing fan directly below a light source to prevent a strobing effect that can be caused by fan rotation.
7. If the building has a mezzanine or other elevated spaces that may be occupied by people, verify that no component of the fan can be reached from the highest level or deck. The fan must be positioned so that the tips of the airfoils are a minimum of 3 ft. away from the furthest point that a person could reach or otherwise come in contact, to prevent injury.
8. If the fan is to be mounted in an area where materials or equipment may be elevated into its path, ensure that the floor is marked or painted to alert personnel of the overhead location of the fan(s).
9. Before installation, it is important to verify that the mounting surface will bear the operating weight and maximum torque (twisting force) of the unit. The Structural Engineer of Record (SEOR) must perform a thorough evaluation of the mounting structure and determine all final mounting requirements before the fan is installed. It is the sole responsibility of the installer to ensure that the mounting structure and fan installation method are adequate for safe operation of the fan.

Fan Size	Fan Diameter (in.)	*Max. Fan Weight (lbs.)	Max Torque (ft-lbf)
4	52	27	1.0
5	60	29	1.1
6	72	31	1.6
7	84	33	2.2

\*Maximum weight is shown in pounds and includes all available options, actual fan weight may be less.

# Minimum Spacing Requirements

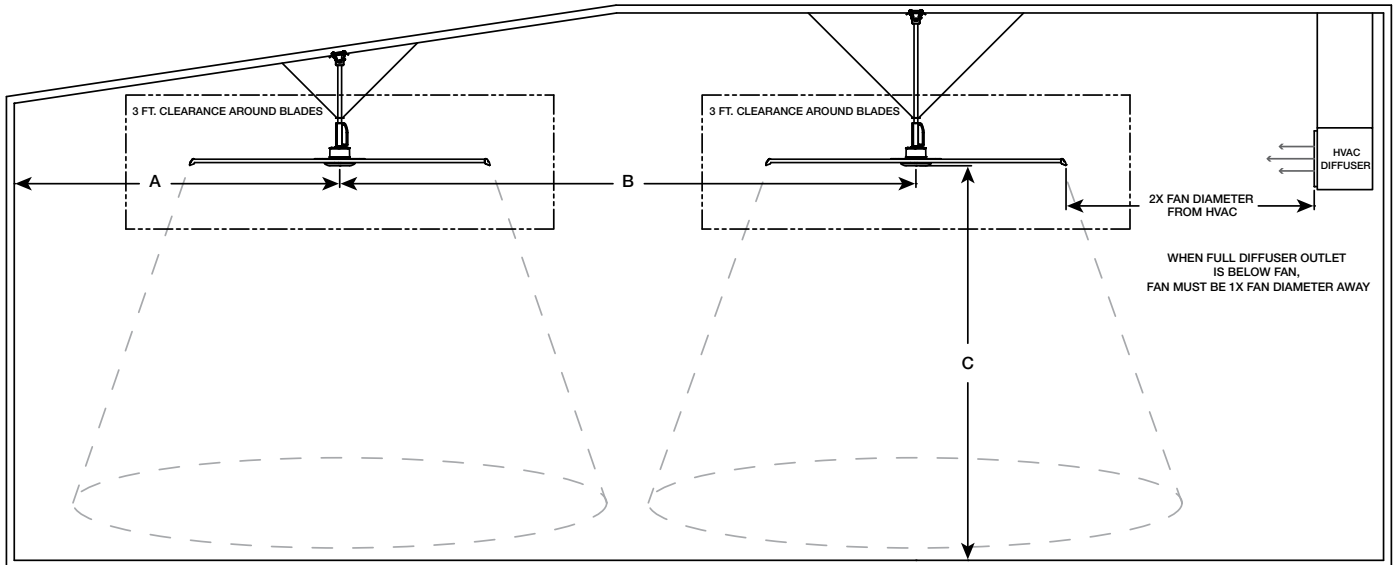

Fan Size	Fan Diameter (in.)	Minimum Spacing From Center of Fan (ft.)		
		A	B	C
4	52	6.5	13	7
5	60	7.5	15	7
6	72	9	18	7
7	84	10.5	21	7

## Mounting Installation

### DANGER

Always disconnect, lock and tag power source before installing or servicing. Failure to disconnect power source can result in fire, shock or serious injury.

### DANGER

Pour écarter les risques d'incendie, de choc électrique ou de blessure grave, veiller à toujours débrancher, verrouiller et étiqueter la source de courant avant l'installation ou l'entretien.

### Fan-Rated Junction Box Mounting with Universal Mounting Kit

**IMPORTANT:** Structural Engineer of Record (SEOR) must perform thorough evaluation of mounting structure and determine final mounting requirements before fan is installed. Manufacturer is not liable for any problems that arise as the result of insufficient structure, including (but not limited to) vibration, noise, or safety hazards. Product warranty will be voided at manufacturer's discretion if structure is deemed insufficient.

Installations must comply with the following requirements at a minimum, but SEOR may require more stringent specifications at their discretion:

- ❑ Fan-rated junction boxes or outlet box systems used as the sole support of a ceiling-suspended (paddle) fan shall be listed, shall be marked by their manufacturer as suitable for this purpose, and shall not support ceiling-suspended (paddle) fans that weigh more than 32 kg (70 lbs.). For fan-rated junction boxes or outlet box systems designed to support ceiling-suspended (paddle) fans that weigh more than 16 kg (35 lbs.), the required marking shall include the maximum weight to be supported.
- ❑ Fan-rated junction box must be directly secured to structural member(s) that are an existing part of the building such as joists/trusses or beams. Do not install fan on junction boxes that are only supported by drywall.

Required Loose Components (Included):

- Universal Mount (1)
- Shielded CAT-5e Control Cable (1)

Hardware/Tools Needed (Not Included):

- Fan-Rated Junction Box with Mounting Hardware (1)
  - #2 Phillips Screwdriver
1. Identify desired mounting location for fan and install a fan-rated junction box (by others) that is listed to support the maximum hanging weight of the fan (refer to page 6). Fan-rated junction box must be installed in accordance with the manufacturer's instructions, and must be adequately secured to building structure for safety.
  2. Route supply power wiring (by others) and the supplied, shielded CAT-5e cable to the fan-rated junction box. Secure wiring to the junction box, making sure to follow all local and national electrical codes.
  3. Install the universal mount on the fan-rated junction box using the fasteners that were provided with the junction box (by others). Make sure to follow the junction box manufacturer's instructions and ensure that fasteners are adequately tightened.

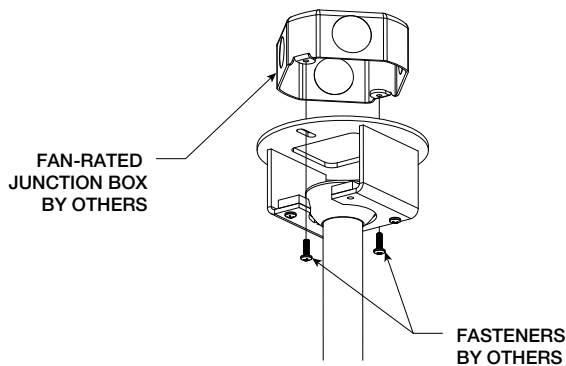

**Alternate Structure Mounting with Universal Mounting Kit**

**IMPORTANT:** Structural Engineer of Record (SEOR) must perform thorough evaluation of mounting structure and determine final mounting requirements before fan is installed. Manufacturer is not liable for any problems that arise as the result of insufficient structure, including (but not limited to) vibration, noise, or safety hazards. Product warranty will be voided at manufacturer's discretion if structure is deemed insufficient.

Installations must comply with the following requirements at a minimum, but SEOR may require more stringent specifications at their discretion:

- ❑ Fans must be directly secured to structural member(s) that are an existing part of the building such as joists/trusses or beams. Do not install fan so that it is only supported by ceiling sheathing.

Required Loose Components (Included):

- Universal Mount (1)
- Shielded CAT-5e Control Cable (1)

Hardware/Tools Needed (Not Included):

- Mounting Hardware, Specified By Others
  - #2 Phillips Screwdriver
1. Identify desired mounting location for fan on structural member(s) that are an existing part of the building. The Structural Engineer of Record (SEOR) must perform a thorough evaluation of the mounting structure and determine all final mounting requirements before the fan is installed. It is the sole responsibility of the installer to ensure that the mounting structure and fan installation method are adequate for safe operation of the fan.
  2. Route supply power wiring (by others) and the supplied, shielded CAT-5e cable to the fan's mounting location. Secure wiring to the building structure, making sure to follow all local and national electrical codes.
  3. Install the universal mount on the bottom surface of the structural member(s) using appropriate fasteners (by others to accommodate varying material properties). Appropriate fasteners to be specified by structural engineer. Make sure that fasteners are adequately tightened.

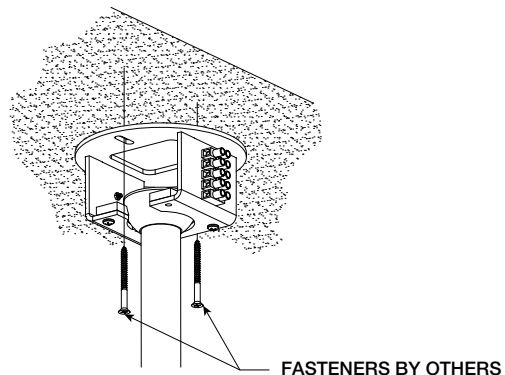



# Motor/Hub to Downtube Installation

## Required Loose Components (Included):

- Mount Cover (1)
- Downtube (1)
- Upper Motor Cover (1)
- Motor/Hub Assembly (1)

## Required Components from Bag # 918029:

- Mounting Ball (1)
- Mounting Ball Pin (1)
- 5/64 in. Hex Key (1)

## Required Components from Bag # 918341:

- #10-24 x 1.5 in. Bolt (1)
- #10-24 Nylon Locknut (1)
- M4x10 Machine Screw (3)

## Hardware/Tools Needed (Not Included):

- Socket Wrench with 5/16 in. Socket
- 3/8 in. Wrench
- Torque Wrench (up to 100 in-lbf)
- #2 Phillips Screwdriver
- Magnetic Level

1. Feed the lower safety retention cable, power wiring pigtail, and communication wiring pigtail that are attached to the motor/hub assembly up through the bottom of the downtube until the loose ends are accessible at the top of the downtube. Pull the loose ends of the safety retention cable and wiring pigtails from the top of the downtube until all of the slack is pulled through.

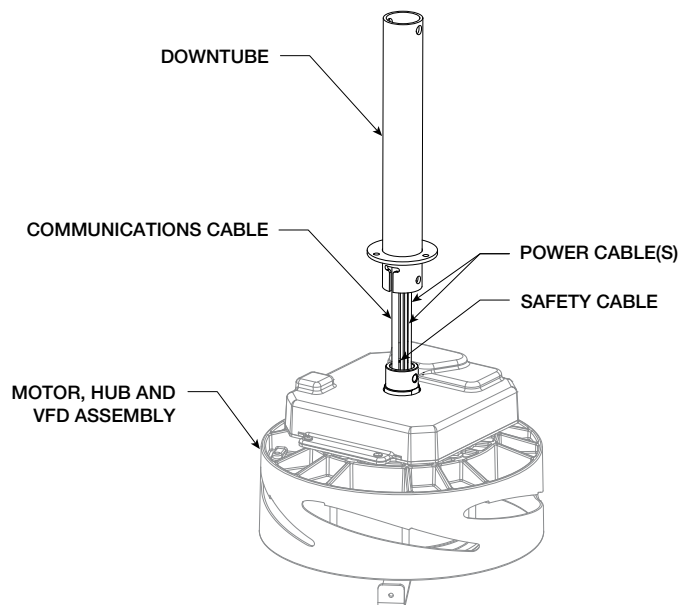

2. Carefully align the motor axle with the downtube opening, then slowly insert the motor axle until the axle is nested inside the downtube. Take care to align the motor axle hole with the downtube hole.

**IMPORTANT:** Do not allow safety cable or wiring to be crushed while nesting the motor axle inside the downtube. Safety cable must be kept taut inside the downtube in order to prevent damage. If either the safety cable or the wiring are damaged during installation, contact your local rep or the manufacturer.

**IMPORTANT:** Do not remove the plastic, factory-installed bushing in the motor axle hole. Plastic bushing protects wiring from being damaged when bolt is inserted.

3. Install the supplied (1) #10-24 x 1.5 in. bolt and (1) #10-24 nylon locknut to secure the motor/hub assembly to the downtube. Torque the bolt to 100 in-lbf.

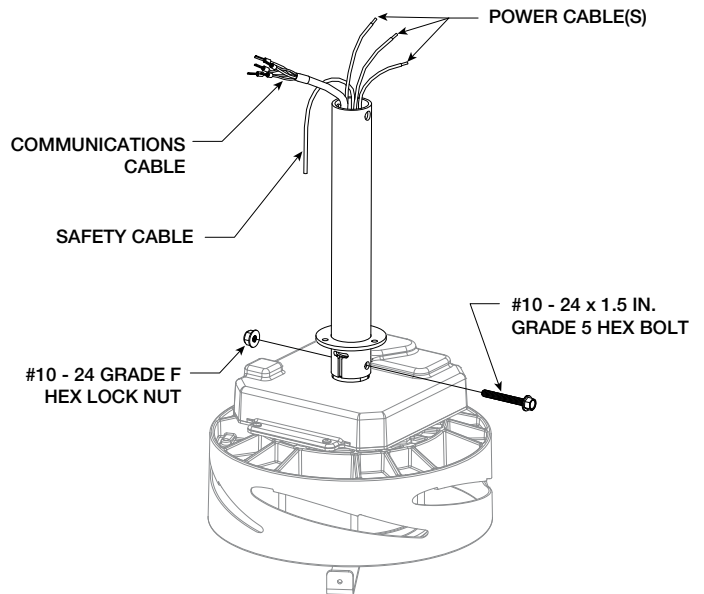

4. Slide the upper motor cover over the downtube until it covers the top side of the motor/hub assembly and rests on the downtube mounting ring. Install (3) M4x10 machine screws to secure the cover to the downtube mounting ring.

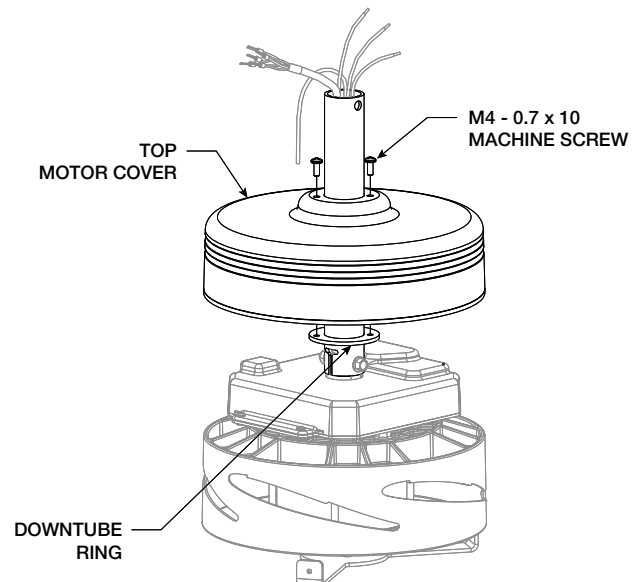

- Slide the mount cover over the downtube until it rests on top of the upper motor cover. Make sure that the mount cover is positioned so that the cavity is facing up.
- Slide the mounting ball over the downtube and align the hole in the ball with the hole in the top of the downtube. Insert the mounting ball pin through the hole, then tighten the set-screw inside the groove on the mounting ball using the provided 5/64 in. hex key.

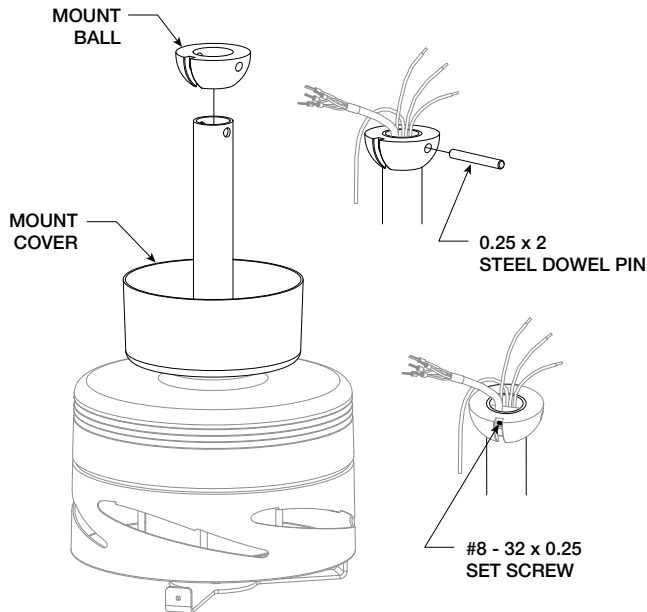

- Align the tab on the universal mount so that it sits inside the groove on the mounting ball.

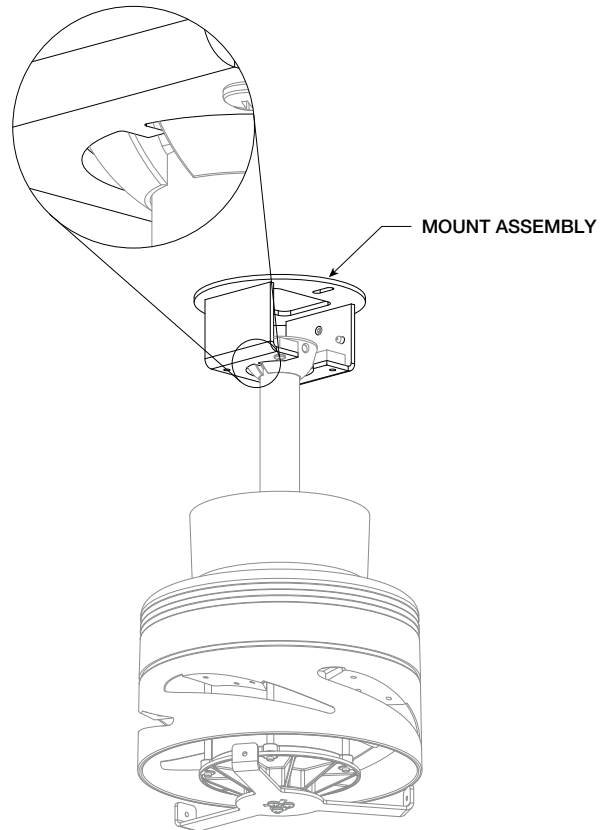

- Hang the motor/hub assembly from the universal mount by inserting the downtube through the opening in the side of the mount.

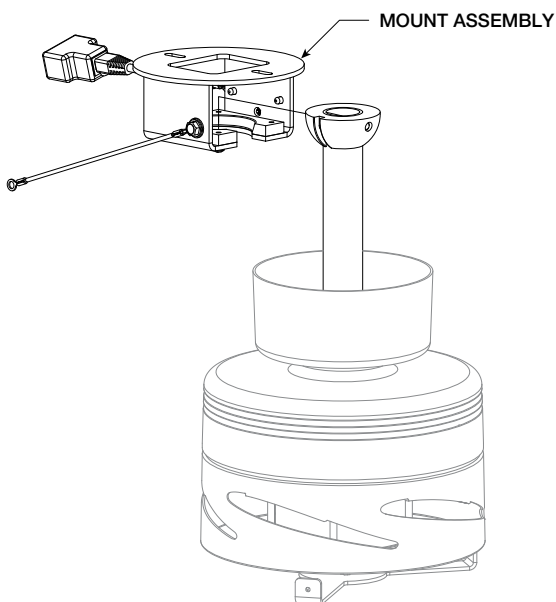

- Place a level against the downtube and adjust the angle of the downtube until the fan is level. Make sure that the tab on the universal mount remains inside the groove on the mounting ball.

**IMPORTANT:** The tab on the universal mount must be inside the groove on the mounting ball to prevent fan tilt, swaying, and other unsafe operation conditions.

# Safety Retention Cable Installation

**NOTE:** Failure to install the safety retention cable will result in voiding of the fan warranty.

Required Components from Bag # 918341:

- Upper Safety Cable (1)
- U-Bolt Steel Cable Clamp (1)

Hardware/Tools Needed (Not Included):

- #2 Phillips Screwdriver
- Socket Wrench with 5/16 in. Socket
- Torque Wrench (up to 100 in-lbf)

1. Attach the upper safety retention cable to the fan-rated junction box or mounting structure using appropriate hardware (by others).
2. Pull the loose end of the lower safety retention cable through the eyelet in the upper safety retention cable and form a loop. Do not allow either cable to come in contact with any sharp edges.
3. Align the loose end of the lower safety cable (referred to as the dead-end) with the length of cable that is sticking out of the downtube (referred to as the live-end).
4. Attach the dead-end of the lower safety cable to the live-end using the supplied U-bolt steel cable clamp. Loosely tighten the nuts on the steel cable clamp, leaving enough room for the lower safety cable to slide through the clamp.
5. Pull the dead-end of the lower safety cable through the steel cable clamp to tighten the cable. The cable should be pulled taut, leaving only a small amount of slack in the cable to ensure proper functioning.
6. Tighten the nuts on the steel cable clamp using a 5/16 in. socket and torque to 54 in-lbf (6.10 N·m), alternating between nuts until reaching proper torque.
7. Trim excess cable making sure to leave at least 3 inches of cable past the steel cable clamp on the dead end.
8. Feed any remaining slack in the lower safety cable inside the cavity of the universal mount or back down the downtube to ensure it does not prevent the mount cover from being installed.

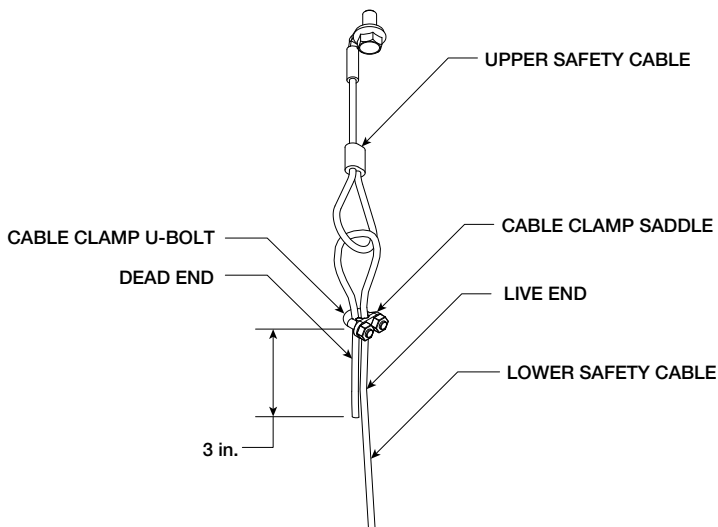

**IMPORTANT:** The steel cable clamp must be installed a minimum of 3 in. away from the dead-end of the lower safety cable to ensure proper functioning.

**IMPORTANT:** Steel cable clamps are composed of two parts: the U-bolt and the saddle. Steel cable clamp must be installed with the U-bolt over the dead-end of the lower safety retention cable and the saddle over the live-end of the lower safety cable. Failure to install steel cable clamps in this manner may result in unsafe operating conditions. Refer to drawings for correct orientation.

# Airfoil Blade and Winglet Installation

## Required Loose Components (Included):

- Airfoil Blade (5)
- Winglet (5)

## Required Components from Bag # 918342:

- M4x10 Machine Screw (5)
- #10-24 x 1 in. Bolt with Thread Locker (15)
- Airfoil Washer Plate (5)

## Hardware/Tools Needed (Not Included):

- Socket Wrench with 5/16 in. Socket
- Torque Wrench (up to 100 in-lbf)
- #2 Phillips Screwdriver

1. Insert one winglet into the hollow cavity of each airfoil blade on the end of the blade with only one bolt hole. Install (1) M4x10 machine screw into the threaded hole to secure the winglet to the blade. Torque screws to 30 in-lbs.

**IMPORTANT:** Do not use an impact driver to tighten screws that secure winglets to airfoil blades. Overtightening may damage the blades or strip the threaded holes in the winglets.

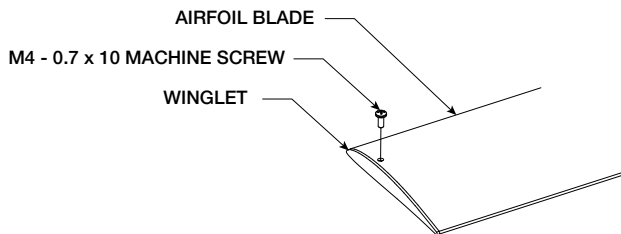
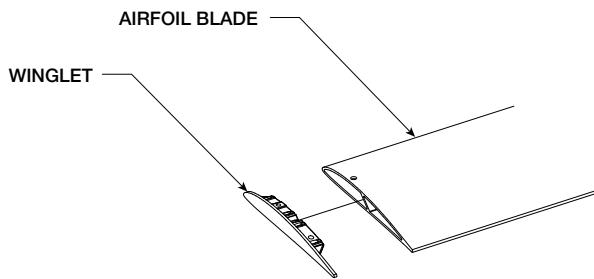

2. Lift the first blade into place and slide inside the opening on the hub until the mounting holes in the blade align with the threaded holes in the hub. It might be necessary to use two people for this step.

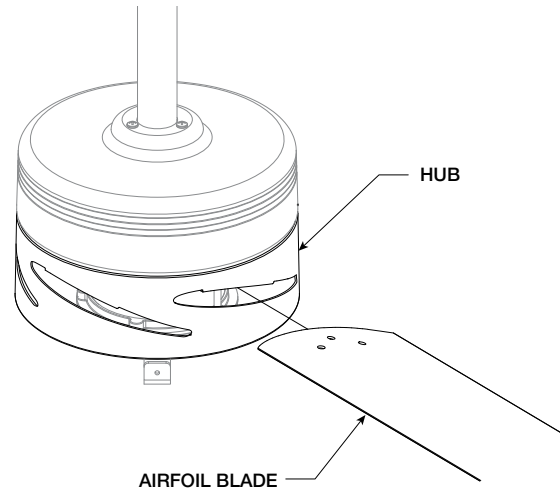

3. With the blade in position, install (1) washer plate and (3) #10-24 x 1 in. bolts into the threaded holes to secure the blade to the hub. Hand tighten hardware, but be careful not to overtighten.

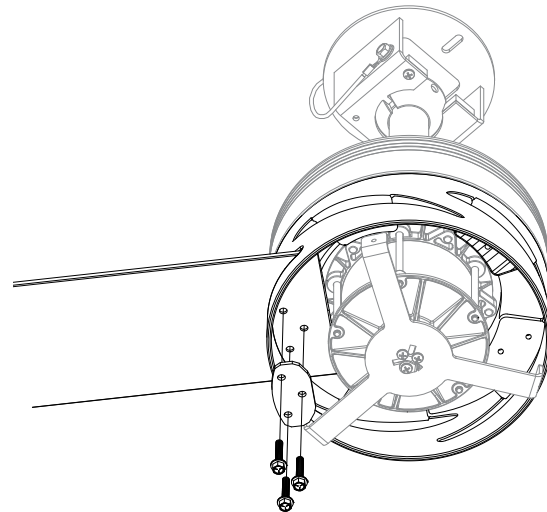

4. Repeat steps 1 through 3 on remaining airfoil blades. Torque the (15) installed bolts to 35 in-lbf, making sure to alternate fasteners until proper torque is achieved on all fasteners.

**IMPORTANT:** Do not use an impact driver to tighten bolts that secure airfoil blades to the hub. Overtightening may damage the blades and hub, or strip the threaded holes.

## Hub Plate Installation

Required Loose Components (Included):

- Hub Plate (1)

Required Components from Bag # 918341:

- M4x10 Machine Screw (3)

Hardware/Tools Needed (Not Included):

- #2 Phillips Screwdriver

1. Align (3) holes in the hub plate with the threaded holes on the hub retention bracket.

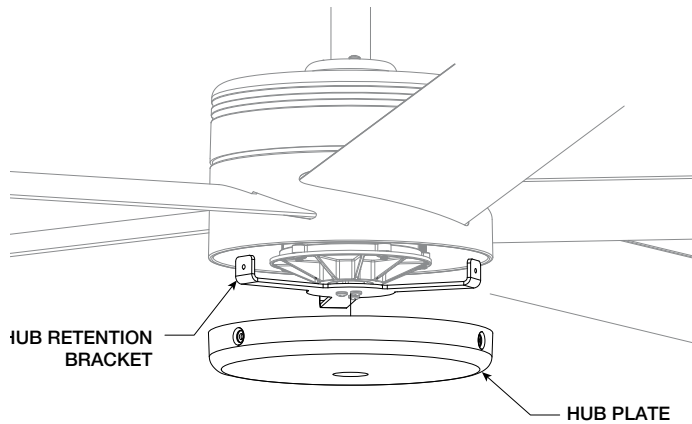

2. Insert (1) M4x10 machine screw per hole and hand tighten to ensure all fasteners will engage the threaded holes.
3. Hand tighten fasteners using a #2 Phillips screwdriver.

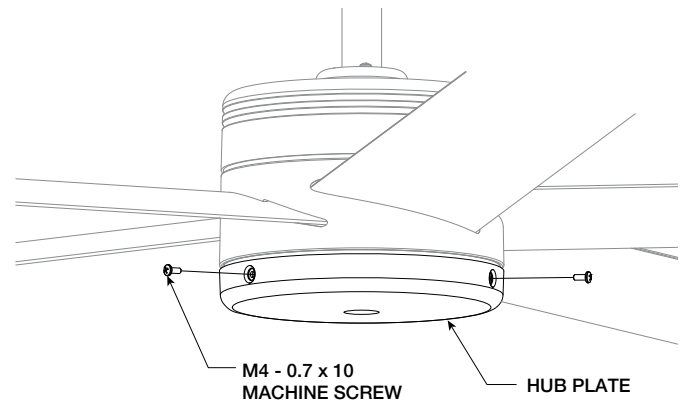

4. Rotate the fan impeller by hand to ensure that it rotates freely and does not rub on the hub plate or come into contact with any obstructions.

## Fire System Integration (Optional)

### DANGER

Always disconnect, lock and tag power source before installing or servicing. Failure to disconnect power source can result in fire, shock or serious injury.

### DANGER

Pour écarter les risques d'incendie, de choc électrique ou de blessure grave, veiller à toujours débrancher, verrouiller et étiqueter la source de courant avant l'installation ou l'entretien.

The following instructions are optional. Fans do not need to be integrated with a building's fire suppression system unless required by local codes or deemed necessary by the authority having jurisdiction (AHJ).

**NOTE:** The following instructions are only applicable to buildings that are equipped with a fire suppression system. If the building does not contain a fire suppression system, leave the jumper wire installed on the enable and ground terminals of the 5-position euro connector (located on the side of the universal mount) and continue with the rest of the installation.

**IMPORTANT:** To ensure proper function of the fire alarm emergency stop feature, fans must be installed using a normally-closed PAM-1 fire alarm relay or an equivalent electromechanical or reed relay. Solid state relays or other digital switching relays cannot be used.

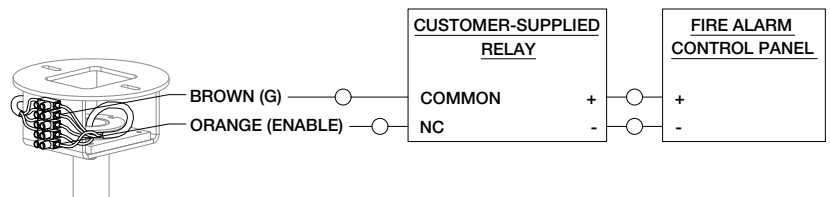

**IMPORTANT:** The fire alarm relay should only be installed by qualified personnel who are familiar with the operation of building fire suppression systems. It is the sole responsibility of the installer to ensure correct operation of the fire alarm relay in the event of a fire emergency in the building.

Hardware/Tools Needed (Not Included):

- Low Voltage (24VDC/VAC or 115VAC), Normally Closed PAM-1 Relay (1)
- 1/8 in. Slotted Screwdriver
- Wire Strippers

1. If the building is equipped with a fire suppression system, remove the factory-installed jumper wire from the ground and enable terminals of the 5-position euro connector located on the side of the universal mount.
2. Wire the normally-closed PAM-1 relay to the ground and enable terminals of the 5-position euro connector, and the building's fire suppression system using the wiring diagram shown below.

# Power Wiring

**IMPORTANT:** Do not apply power until mechanical installation, communication wiring, and fan control installation are complete.

**IMPORTANT:** Do not apply power to the fan above the rated voltage of the variable frequency drive (VFD). Failure to comply with this warning will result in voiding of the product warranty and may result in permanent damage to the VFD and motor.

**IMPORTANT:** To prevent electrical failures, source power must comply with the following power quality requirements. If source power falls outside of these specified tolerances, an external power line filter will be required (by others). If other power quality issues are present, contact the factory for support.

Allowable Voltage Fluctuation	+/- 10% of nominal
Allowable Frequency Fluctuation	+/- 5% of nominal (47-63 Hz)
Area of Use	Do not install fans in electrical environments with Pollution higher than Degree 2 in accordance with UL 61800-5-1
Surge Immunity	Do not install fans in electrical environments above Installation Class 3 in accordance with IEC 61000-4-5

Required Components from Bag # 918341:

- Electrical Lever Connector (3)

Hardware/Tools Needed (Not Included):

- #2 Phillips Screwdriver

1. Using the supplied electrical lever connectors, connect supply power wiring to the factory-installed wiring pigtail. Refer to the wiring diagram below.

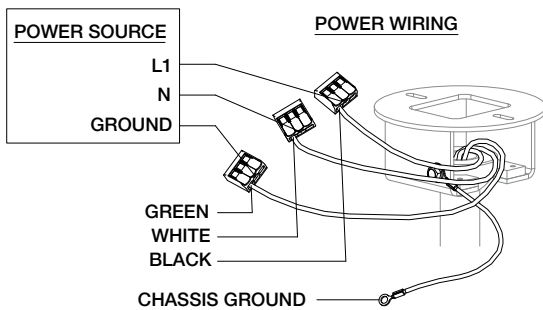

2. Connect the chassis ground wire to the fan-rated junction box or building structure using appropriate fastener (by others).

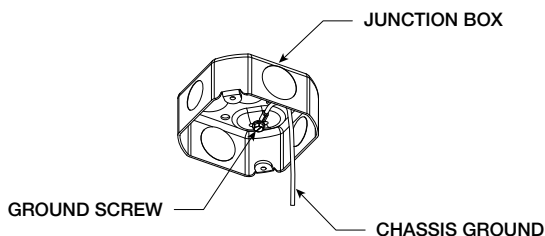

3. Feed any loose power wiring inside the cavity of the universal mount or back down the downtube to ensure it does not prevent the mount cover from being installed.

## Disconnect and Fuse Installation

1. If provided, mount and wire the optional safety disconnect switch outside of the sweep of the fan's airfoil blades. Installation should be completed per the disconnect manufacturer's recommendation. Be sure to follow all national and local codes for electrical installation.
2. If fusing is required, refer to the fuse sizing charts included below. If the fan was supplied with the optional fused disconnect, the fuses received will match the model shown below. Install fuses per the manufacturer's recommendation. Be sure to follow all national and local codes for electrical installation.

Fuse Sizing Chart	
VCFC-5 (4.3 to 7 ft.), 50W Motor	
Motor Voltage	115V/60 Hz/1 PH
Motor Full Load Amps (FLA)*	1.5
Fuse Required**	FRS-R-5

\* FLA is based on worst case system conditions assuming lowest nominal voltage and phase.

\*\* Fuses shown are available as an optional accessory. Fuses provided by others must meet requirements of all national and local codes.

## Communication Wiring

**IMPORTANT:** VCFC fans must be installed with the supplied CAT-5e communication cable or shielded CAT-5e (by others) that complies with the following specifications. Cable must be twisted pair, shielded 26 AWG CAT-5e cable with a drain wire and must be compliant with ISO 11801. Cable must use shielded RJ45 connectors with a soldered drain and wiring configuration must follow EIA/TIA T568B wiring pinout. Individual CAT-5e cable lengths must not exceed 200 ft. in order to prevent network communication issues.

### With Pre-Built CAT-5e Cable

Required Loose Components (Included):

- Shielded CAT-5e Control Cable (1)

Required Components from Bag # 918341:

- M4x10 Machine Screw (3)

Hardware/Tools Needed (Not Included):

- 1/8 in. Slotted Screwdriver

1. Connect the fan's communication wiring pigtail to the open side of the 5-position euro connector installed on the universal mount. Make sure that the wire colors are installed as shown below.

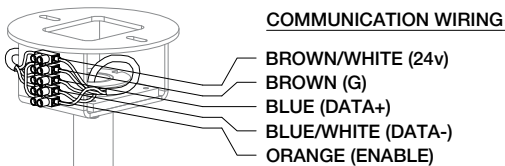

2. Plug one end of the shielded CAT-5e control cable that was previously routed to the fan's mounting location into the 2-way RJ45 splitter located at the universal mount. The cable can be plugged into any open receptacle on the splitter.

**SHIELDED TWISTED PAIR CAT-5e CONNECTION**

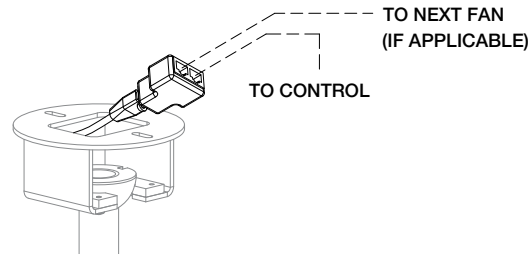

3. Feed any loose communication wiring inside the cavity of the universal mount or back down the downtube to ensure it does not prevent the mount cover from being installed.
4. Identify the desired location for installation of the fan control and run the remainder of the shielded CAT-5e control cable to this location.
5. Secure the shielded CAT-5e control cable to the building structure to ensure it does not interfere with fan performance. To prevent communication issues, do not coil excess control cable or route control cable with power wiring.
6. If one control source will be used to operate multiple fans, the fans can be daisy-chained together to create a network using the following instructions.
  - a. Connect a shielded CAT-5e control cable to the first fan in the daisy-chain using steps 1-3 above.
  - b. Plug an additional CAT-5e control cable into the 2-way RJ45 splitter located at the top of the downtube on the first fan. Connect the other end of this CAT-5e cable into the 2-way splitter on the next fan.
  - c. Repeat step 6b. for subsequent fans until all fans in the chain are connected in series.

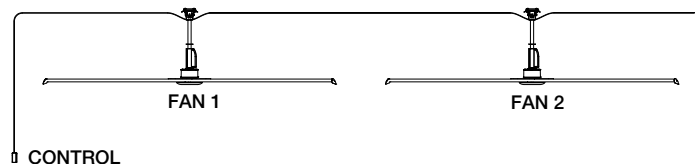

## With Optional 1,000 ft. Bulk Spool of CAT-5e Cable

### Required Loose Components (Included):

- 1,000 ft. Bulk Spool of CAT-5e Control Cable (1)
- Shielded, Pass-Through RJ45 Connectors (25)

### Hardware/Tools Needed (Not Included):

- CAT-5e Termination Tool

1. Determine required length of CAT-5e cable run. Unspool appropriate amount of cable and cut to length.

**IMPORTANT:** Individual CAT-5e cable lengths must not exceed 200 ft. in order to prevent network communication issues.

2. Strip and remove 2 in. of CAT-5e cable jacket leaving the foil shield intact.
3. Fold foil shield back over cable jacket and trim foil so that 1/4 in. remains.
4. Untwist conductor pairs, straighten and align wires according to EIA/TIA T568B wiring pinout.

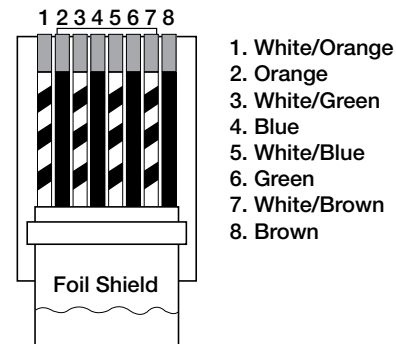

**NOTE:** RJ45 connector in this image is shown with clip pointed away from installer.

5. Trim conductor ends flush leaving 1 in. exposed.
6. Fully insert cable into shielded, pass-through RJ45 connectors until foil enters back end of connector. Use only the provided RJ45 connectors.
7. Verify that conductors are in the correct wiring scheme order.
8. Crimp RJ45 connector with CAT-5e termination tool (not included).
9. Repeat on opposite end of CAT-5e cable to complete cable construction.
10. Follow the “With Pre-Built CAT-5e Cable” instructions on page 15 to complete communication wiring and fan control installation.



# Fan Networking

If networking multiple fans to run using a single control source, the wiring on each fan's 5-position euro connector will need to be adjusted using the following instructions.

## First Fan

Required Components from Bag # 918342:

- M4x10 Machine Screw (2)

Hardware/Tools Needed (Not Included):

- #2 Phillips Screwdriver
- 1/8 in. Slotted Screwdriver

1. Determine the first fan in the network daisy-chain by identifying the fan that will be directly connected to the control source.
2. Verify that the low voltage wiring is installed on the 5-position euro connector located on the side of the universal mount as shown in the diagram and picture on this page.
3. Install the mount cover using (2) M4x10 machine screws.

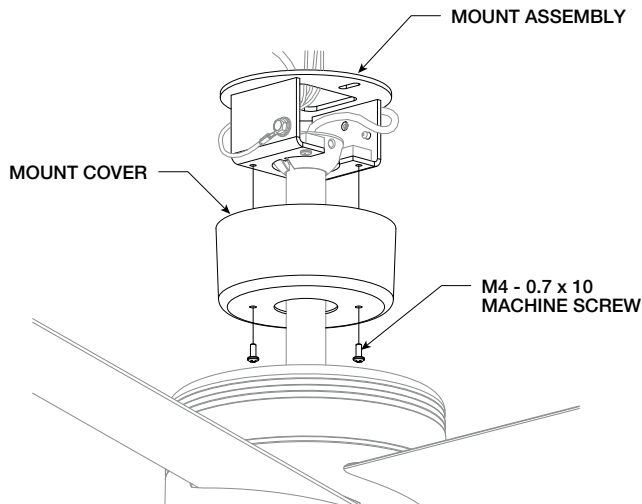
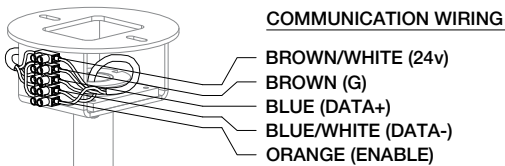

4. Apply power to the first fan in the network daisy-chain.

**IMPORTANT:** Do not apply power to any additional fans in the network. Modbus addresses cannot be set with multiple fans powered on.

5. Set the desired Modbus address for the fan using the instructions provided with the fan control. A table with all possible Modbus addresses is shown below.
6. Turn network biasing on for the fan using the instructions provided with the fan control.
7. Disconnect power to the first fan in the network daisy-chain before proceeding.

Fan Number	Modbus Address
N/A - RESERVED FOR HVLS FAN CONTROLS	1
1	2
2	3
3	4
4	5
5	6
6	7
7	8
8	9
9	10
10	11
11	12
12	13
13	14
14	15
15	16
16	17
17	18
18	19
19	20
20	21
21	22
22	23
23	24
24	25
25	26
26	27
27	28

## All Remaining Fans

Required Components from Bag # 918342:

- M4x10 Machine Screw (2)

Hardware/Tools Needed (Not Included):

- #2 Phillips Screwdriver
- 1/8 in. Slotted Screwdriver

1. On the 5-position euro connector located on the side of the universal mount, remove the 24V (brown-white) wire and cap with a wire nut or heat shrink. When complete, verify that the low voltage wiring is installed on the 5-position euro connector as shown in the diagram and picture on this page.

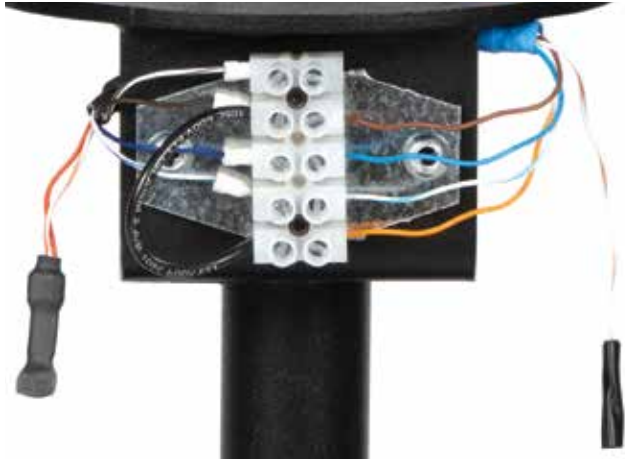
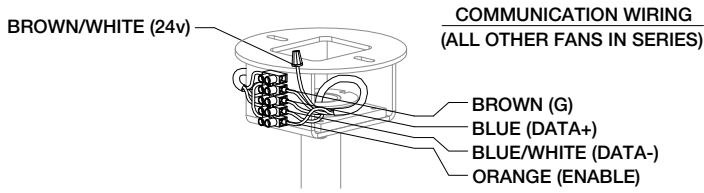

2. Install the mount cover using (2) M4x10 machine screws.

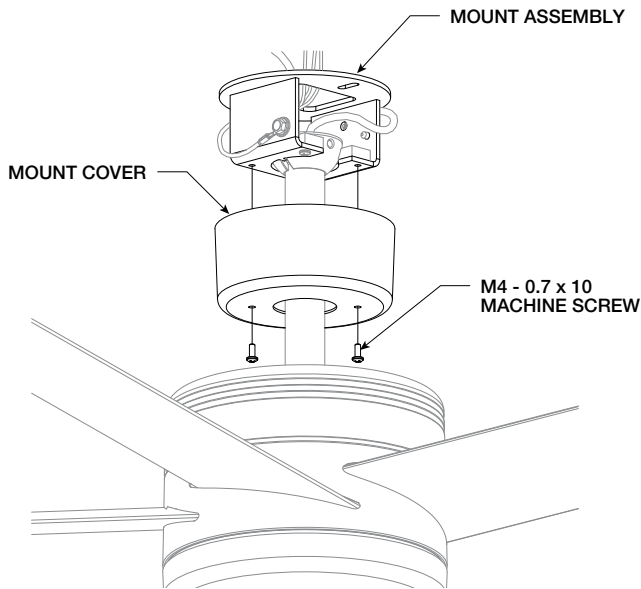

3. Apply power to the next fan in the network daisy-chain.

**IMPORTANT:** Do not apply power to any additional fans in the network. Modbus addresses cannot be set with multiple fans powered on.

4. Set the desired Modbus address for the current fan using the instructions provided with the fan control. Make sure that each successive fan has a unique Modbus address. A table with all possible Modbus addresses is shown below.

**NOTE:** It is good practice to use successive Modbus addresses for networked fans, but this is not necessary for proper functioning of the network.

5. Verify that network biasing is turned off for the current fan using the instructions provided with the fan control.
6. Disconnect power to the current fan.
7. Repeat steps 3-6 for each successive fan in the network daisy-chain.

Fan Number	Modbus Address
N/A - RESERVED FOR HVLS FAN CONTROLS	1
1	2
2	3
3	4
4	5
5	6
6	7
7	8
8	9
9	10
10	11
11	12
12	13
13	14
14	15
15	16
16	17
17	18
18	19
19	20
20	21
21	22
22	23
23	24
24	25
25	26
26	27
27	28

## Pre-Start-Up Checks

1. Disconnect and lock-out all power switches to fan.
2. Check all fasteners and set screws on the universal ceiling mount, mounting ball, mount cover, upper motor cover, impeller, motor/hub assembly, hub plate, and accessories for tightness.
3. Rotate the fan impeller by hand to ensure that it rotates freely and does not rub on the hub plate or come into contact with any obstructions.
4. Check all electrical connections for proper attachment.
5. Verify that the fan is hanging so that the airfoils and downtube are level and the fan is plumb to the floor. Make sure that the tab on the universal mount remains inside the groove on the mounting ball if adjustments are made to the fan's hanging position.

## Fan Operation

**IMPORTANT:** If unusual vibration or oscillating movement is observed during fan operation, immediately discontinue use of the fan and contact the manufacturer or a suitably qualified maintenance/repair technician.

1. When the fan is started, observe the operation and check for any unusual noise, vibration or overheating. Refer to the Troubleshooting section of this manual if a problem develops.
2. With the system in full operation, measure current input to the VFD and compare with the FLA ratings in the tables above to determine if the motor/VFD system is operating under safe load conditions.
3. Keep approaches to fan clean and free from obstruction.

## Fan Inspection

### DANGER

Disconnect and secure to the 'OFF' position all electrical power to the fan prior to inspection or servicing. Failure to comply with this safety precaution could result in serious injury or death.

### DANGER

Pour écarter les risques de blessure grave ou de mort, débrancher et verrouiller l'alimentation électrique en position « Arrêt » avant tout contrôle ou entretien.

Inspection of the fan should be conducted at the first 30 minute and 24 hour intervals of satisfactory operation.

- 30 Minute Interval - Check all fasteners for tightness. Adjust and tighten as necessary.
- 24 Hour Interval - Inspect all fan components. Check all fasteners and safety retention cable. Adjust and tighten as necessary.

## Fan Maintenance

### DANGER

Disconnect and secure to the 'OFF' position all electrical power to the fan prior to inspection or servicing. Failure to comply with this safety precaution could result in serious injury or death.

### DANGER

Pour écarter les risques de blessure grave ou de mort, débrancher et verrouiller l'alimentation électrique en position « Arrêt » avant tout contrôle ou entretien.

**NOTE:** Installation and maintenance are to be performed only by qualified personnel who are familiar with local codes and regulations and have experience with this type of equipment.

Once the fan has been put into operation, a periodic maintenance program should be set up to ensure reliable fan performance. A proper maintenance program will help deliver years of dependable service. Items to be included in this program are as follows:

1. Verify that all fasteners are tight and properly torqued.
2. Verify that all of the fan's safety systems (safety cable, hub retaining bracket) are properly installed. Inspect for signs of damage or failure.

3. Inspect the fan for signs of fatigue, corrosion, or wear.
4. Impellers require little attention when moving clean air. Occasionally, oil and dust may accumulate causing imbalance. When this occurs, clean the impeller and other fan components to ensure smooth and safe operation. Remove any accumulated dust and dirt using hot water or mild cleaning solutions. Harsh chemicals should not be used to clean the fan as they may damage the fan's finish or motor.

**IMPORTANT:** Do not allow water or solvents to enter the motor. Under no circumstances should motors be sprayed with steam, water or solvents.

5. Motor maintenance is generally limited to cleaning. Limit cleaning to exterior surfaces only. Removing dust buildup on motor housing ensures proper motor cooling.
6. Prior to restarting unit, check all fasteners for tightness each time maintenance checks are performed.

## Troubleshooting

### DANGER

Disconnect and secure to the 'OFF' position all electrical power to the fan prior to inspection or servicing. Failure to comply with this safety precaution could result in serious injury or death.

### DANGER

Pour écarter les risques de blessure grave ou de mort, débrancher et verrouiller l'alimentation électrique en position « Arrêt » avant tout contrôle ou entretien.

Each fan bears a manufacturer's nameplate with the fan's model number and a unique serial number for identification. This information will assist the local representative and the manufacturer in providing service and replacement parts.

**IMPORTANT:** Do not remove VFD enclosure or VFD circuit board from motor/hub assembly under any circumstances. Removal of the VFD or VFD circuit board will result in voiding of the fan warranty.

## Fan Balancing (Optional)

Required Components from Bag # 918439:

- Clip-on Balance Weights (8)
- Permanent Balance Weights (8)

1. If unbalance or swaying are observed during fan operation, add the (4) supplied clip-on weights to one airfoil blade. Turn the fan on and observe fan operation. Take note if fan balance is improved.
  2. Move the (4) clip-on weights to each blade and repeat step 1 to determine which blade requires permanent balancing weights to be applied.
3. Once the ideal blade is identified, move the clip-on weights from the blade tip towards the motor hub to identify the appropriate location for weights to be applied. Test fan operation at multiple locations until best operation is observed.
4. After identifying the appropriate location and quantity of weights to apply, replace the clip-on weights with permanent weights using the same quantity and location.

## General Troubleshooting

Problem: Unknown, Initial Troubleshooting Steps.				
1	Is supply power turned on at all circuit breakers and fan disconnects?	Yes ⬇️	No ⬇️	<b>No supply power to fans.</b> Turn circuit breakers and disconnects to “on” position.
2	Is there line voltage across L1 and L2/N on supply power wiring?	Yes ⬇️	No ⬇️	<b>Supply power wiring not connected.</b> Connect proper power supply to fan. Refer to wiring diagram on page 14.
3	Are line voltage measurements within +/- 10% of nominal voltage across L1 and L2/N on supply power wiring?	Yes ⬇️	No ⬇️	<b>Phase imbalance or incorrect supply power applied to fan.</b> Correct supply power wiring to fan.
4	Are resistance measurements between 500k Ohms and Open across L1 and L2/N on power wiring? Are resistance measurements Open across L1 and GND, and L2/N and GND on power wiring?	Yes ⬇️	No ⬇️	<b>Electrical short in supply power wiring.</b> Replace supply power wiring.
5	Were fans and controls installed using only the provided networking components (green shielded CAT-5e cables, black shielded 3-way RJ45 splitters) or components that comply with specifications on page 15?	Yes ⬇️	No ⬇️	<b>Networking components may be defective, incorrectly wired, or do not meet required specifications.</b> Replace with provided components or components that comply with specifications on page 15.
6	Are 3-way RJ45 splitters installed with the single-port side connected to black cable inside fan downtube?	Yes ⬇️	No ⬇️	<b>Incorrect splitter orientation.</b> Unplug splitter and reconnect in the proper orientation.
7	Have all CAT-5e cable connections been unplugged and reconnected to ensure that cables are fully seated (will hear a “click” when fully seated)?	Yes ⬇️	No ⬇️	<b>Loose or misaligned CAT-5e cable connection.</b> Unplug and reconnect all CAT-5e cable connections.
8	Are the Modbus addresses and biasing settings set as shown on pages 16-18 for all fans?	Yes ⬇️	No ⬇️	<b>Incorrect Modbus and/or biasing settings on one or multiple VFDs.</b> Adjust Modbus addresses and biasing settings as shown on pages 16-18. All fans must have a unique Modbus address setting.
9	Does communication wiring on VFD of fan 1 (directly connected to control via shielded CAT-5e cable) match the wiring diagram for fan 1 on page 16?	Yes ⬇️	No ⬇️	<b>Communication wiring on fan 1 is incorrect.</b> Turn off supply power to fan and correct wiring as shown in wiring diagram on page 16. Then turn supply power on.
10	Does communication wiring on VFDs of all remaining fans match the wiring diagram for all remaining fans on page 17?	Yes ⬇️	No ⬇️	<b>Communication wiring on one or multiple fans is incorrect.</b> Turn off supply power to fans and correct wiring as shown in wiring diagram on page 17. Then turn supply power on.
11	Do fans operate as expected?	Yes ⬇️	No ⬇️	<b>Check detailed troubleshooting steps on the following pages or contact the factory.</b>
<b>Everything is working properly.</b>				

## Controls Troubleshooting

Problem: Standard Touchscreen control will not turn on.				
1	Is the 24V wire (brown-white) connected on euro connector of fan 1 (directly connected to control via shielded CAT-5e cable)?	Yes ⬇️	No ⬇️	<b>No supply power to control.</b> Controls are powered by VFD on fan 1 (directly connected to control via shielded CAT-5e cable). Connect the 24V wire (brown-white) to the euro connector of fan 1. Refer to instructions on page 16.
2	Is supply power turned on at all circuit breakers and fan disconnects?	Yes ⬇️	No ⬇️	<b>No supply power to fans.</b> Turn circuit breakers and disconnects to “on” position.
3	Were fans and controls installed using only the provided networking components (green shielded CAT-5e cables, black shielded 3-way RJ45 splitters) or components that comply with specifications on page 15?	Yes ⬇️	No ⬇️	<b>Networking components may be defective, incorrectly wired, or do not meet required specifications.</b> Replace with provided components or components that comply with specifications on page 15.
4	Are 3-way RJ45 splitters installed with the single-port side connected to black cable inside fan downtube?	Yes ⬇️	No ⬇️	<b>Incorrect splitter orientation.</b> Unplug splitter and reconnect in the proper orientation.
5	Have all CAT-5e cable connections been unplugged and reconnected to ensure that cables are fully seated (will hear a “click” when fully seated)?	Yes ⬇️	No ⬇️	<b>Loose or misaligned CAT-5e cable connection.</b> Unplug and reconnect all CAT-5e cable connections.
6	Does the screen on the control light up?	Yes ⬇️	No ⬇️	<b>Contact factory.</b>
<b>Everything is working properly.</b>				

<b>Problem: Advanced Touchscreen control will not turn on.</b>				
1	Is the power adapter cable wired into the control panel?	Yes ⬆️	No ⬇️	<b>No supply power to control panel.</b> Wire the power adapter cable into the control panel as shown in the wiring diagram in the control manual.
2	Is the power adapter connected to a 115V electrical outlet?	Yes ⬆️	No ⬇️	<b>No supply power to control panel.</b> Connect the power adapter to a 115V electrical outlet.
3	Is supply power turned on at the circuit breaker for 115V electrical outlet?	Yes ⬆️	No ⬇️	<b>No supply power to control panel.</b> Turn circuit breaker to “on” position.
4	Is the shielded RJ12 cable wired into the control panel?	Yes ⬆️	No ⬇️	<b>No supply power or communications to touchscreen interface.</b> Wire the shielded RJ12 cable into the control panel as shown in the wiring diagram in the control manual.
5	Is the shielded RJ12 cable connected to the touchscreen interface?	Yes ⬆️	No ⬇️	<b>No supply power or communications to touchscreen interface.</b> Connect the shielded RJ12 cable to the open port on the back of the touchscreen interface.
6	Has the shielded RJ12 cable been unplugged and reconnected to the touchscreen interface to ensure that it is fully seated (will hear a “click” when fully seated)?	Yes ⬆️	No ⬇️	<b>Loose or misaligned RJ12 cable connection.</b> Unplug and reconnect shielded RJ12 cable to the open port on the back of the touchscreen interface.
7	Does the screen on the touchscreen interface light up?	Yes ⬆️	No ⬇️	<b>Contact factory.</b>
<b>Everything is working properly.</b>				

<b>Problem: One or more fans not found by control.</b>				
1	Were fans and controls installed using only the provided networking components (green shielded CAT-5e cables, black shielded 3-way RJ45 splitters) or components that comply with specifications on page 15?	Yes ⬆️	No ⬇️	<b>Networking components may be defective, incorrectly wired, or do not meet required specifications.</b> Replace with provided components or components that comply with specifications on page 15.
2	Does communication wiring on euro connector of fan 1 (directly connected to control via shielded CAT-5e cable) match the wiring diagram for fan 1 on page 16?	Yes ⬆️	No ⬇️	<b>Communication wiring on fan 1 is incorrect.</b> Turn off supply power to fan and correct wiring as shown in wiring diagram on page 16. Then turn supply power on.
3	Are the Modbus addresses and biasing settings set as shown on page 17 for fan 1?	Yes ⬆️	No ⬇️	<b>Incorrect Modbus and/or biasing settings on fan 1.</b> Adjust Modbus address and biasing settings as shown on page 17. All fans must have a unique Modbus address setting.
4	Does communication wiring on euro connector of fan 2 (directly connected to fan 1 via shielded CAT-5e) match the wiring diagram for “all remaining fans” on page 17?	Yes ⬆️	No ⬇️	<b>Communication wiring on fan 2 is incorrect.</b> Turn off supply power to fan and correct wiring as shown in wiring diagram on page 17. Then turn supply power on.
5	Are the Modbus addresses and biasing settings for fan 2 (directly connected to fan 1 via shielded CAT-5e cable) set as shown for “all remaining fans” on page 18?	Yes ⬆️	No ⬇️	<b>Incorrect Modbus and/or biasing settings on fan 2.</b> Adjust Modbus address and biasing settings as shown on page 18. All fans must have a unique Modbus address setting.
6	After repeating steps 4-5 for all remaining fans, can all fans be found using autodetect feature on control?	Yes ⬆️	No ⬇️	<b>Contact factory.</b>
<b>Everything is working properly.</b>				

## Fan Troubleshooting

Problem: One or more fans found by control but will not run.				
1	Have all fault codes been acknowledged and reset on fan control?	Yes ⬇	No ⬆	<b>One or more fans may have experienced a fault.</b> Refer to list of fault codes on page 26 for detailed descriptions. Acknowledge and reset all faults, then cycle power to fans. Fans will only operate when Op Status code is equal to 0. Refer to instructions in the control manual for accessing Op Status code.
2	Is the control set to a speed greater than 0 and have the fans been turned on via the control's power button?	Yes ⬇	No ⬆	<b>Control is not sending a run command to fans.</b> Set speed to a value between 1-10 and press the control's power button to turn fans on. Control will indicate that fans are on by displaying a green power icon or stating "On".
3	Do fans operate as expected?	Yes ⬇	No ⬆	<b>Contact factory.</b>
<b>Everything is working properly.</b>				

Problem: One or more fans attempt to run, but do not rotate completely.				
1	Are fan size and blade count set appropriately in the control for all installed fans?	Yes ⬇	No ⬆	<b>Incorrect torque/speed command to fans.</b> Set fan size and blade count using instructions in the control manual. Fan size and blade count must be set to match physical product.
2	Rotate all fans by hand. Can fans rotate freely without any audible rubbing, scraping, or grinding noise?	Yes ⬇	No ⬆	<b>Rubbing components on the fan hub and/or airfoils.</b> Correct any issues that are found.
3	Do fans operate as expected?	Yes ⬇	No ⬆	<b>Contact factory.</b>
<b>Everything is working properly.</b>				

Problem: One or more fans run intermittently, but will not run consistently.				
1	Have all fault codes been acknowledged and reset on fan control?	Yes ⬇	No ⬆	<b>One or more fans may have experienced a fault.</b> Refer to list of fault codes on page 26 for detailed descriptions. Acknowledge and reset all faults, then cycle power to fans. Fans will only operate when Op Status code is equal to 0. Refer to instructions in the control manual for accessing Op Status code.
2	Are line voltage measurements within +/- 10% of nominal voltage across L1 and L2/N on supply power wiring?	Yes ⬇	No ⬆	<b>Phase imbalance or incorrect supply power applied to fan.</b> Correct supply power wiring to fan.
3	Are resistance measurements between 500k Ohms and Open across L1 and L2/N on power wiring? Are resistance measurements Open across L1 and GND, and L2/N and GND on power wiring?	Yes ⬇	No ⬆	<b>Electrical short in supply power wiring.</b> Replace supply power wiring.
4	Were fans and controls installed using only the provided networking components (green shielded CAT-5e cables, black shielded 3-way RJ45 splitters) or components that comply with specifications on page 15?	Yes ⬇	No ⬆	<b>Networking components may be defective, incorrectly wired, or do not meet required specifications.</b> Replace with provided components or components that comply with specifications on page 15.
5	Have all CAT-5e cable connections been unplugged and reconnected to ensure that cables are fully seated (will hear a "click" when fully seated)?	Yes ⬇	No ⬆	<b>Loose or misaligned CAT-5e cable connection.</b> Unplug and reconnect all CAT-5e cable connections.
6	Are the Modbus addresses and biasing settings set as shown on pages 16-18 for all fans?	Yes ⬇	No ⬆	<b>Incorrect Modbus and/or biasing settings on one or multiple VFDs.</b> Adjust Modbus addresses and biasing settings as shown on pages 16-18. All fans must have a unique Modbus address setting.
7	Do fans operate as expected?	Yes ⬇	No ⬆	<b>Contact factory.</b>
<b>Everything is working properly.</b>				

Problem: One or more fans run, but are making excessive noise/vibrating.				
1	Have all fasteners been torqued to the appropriate values listed in the Installation, Operation and Maintenance Manual?	Yes ⬇️	No ⬇️	<b>Loose fasteners.</b> Torque all fasteners to the appropriate values. Refer to pages 7-13 for torque specifications of each fastener.
2	Is the downtube level on all sides for all installed fans?	Yes ⬇️	No ⬇️	<b>Fans not installed level.</b> Refer to page 10 for fan levelling instructions.
3	Rotate all fans by hand. Can fans rotate freely without any audible rubbing, scraping, or grinding noise?	Yes ⬇️	No ⬇️	<b>Rubbing components on the fan hub and/or airfoils.</b> Correct any issues that are found.
4	Has noise/vibration ceased?	Yes ⬇️	No ⬇️	<b>Contact factory.</b>
<b>Everything is working properly.</b>				

Problem: One or more fans run, but I don't feel much airflow.				
1	Are fans installed with a minimum of 1 foot of clearance to ceiling structure?	Yes ⬇️	No ⬇️	<b>Fan is starved for air.</b> Correct installation to maintain minimum clearance requirements.
2	Are fan size and blade count set appropriately in the control for all installed fans?	Yes ⬇️	No ⬇️	<b>Incorrect torque/speed command to fans.</b> Set fan size and blade count using instructions in the control manual. Fan size and blade count must be set to match physical product.
3	Is the control set to the maximum fan speed (speed setting of 10)?	Yes ⬇️	No ⬇️	<b>Fan speed too low. Increase fan speed until desired airflow is achieved.</b> Refer to instructions in the control manual.
4	Is the control set to forward (downward airflow) operation?	Yes ⬇️	No ⬇️	<b>Fan operating in reverse (upward airflow).</b> Refer to instructions in the control manual to change direction of operation.
5	Are airfoil blades installed so that the concave or cupped side is pointing down?	Yes ⬇️	No ⬇️	<b>Airfoil blades are installed upside down.</b> Remove and reinstall airfoil blades so that the concave or cupped side is pointing down towards the floor. Refer to instructions on page 12.
6	Do fans operate as expected?	Yes ⬇️	No ⬇️	<b>Contact factory.</b>
<b>Everything is working properly.</b>				

Problem: One or more fans not operating at expected RPM (too fast or too slow).				
1	Are fan size and blade count set appropriately in the control for all installed fans?	Yes ⬇️	No ⬇️	<b>Incorrect torque/speed command to fans.</b> Set fan size and blade count using instructions in the control manual. Fan size and blade count must be set to match physical product.
2	Rotate all fans by hand. Can fans rotate freely without any audible rubbing, scraping, or grinding noise?	Yes ⬇️	No ⬇️	<b>Rubbing components on the fan hub and/or airfoils.</b> Correct any issues that are found.
3	Do fans operate as expected?	Yes ⬇️	No ⬇️	<b>Contact factory.</b>
<b>Everything is working properly.</b>				



<b>Problem: One or more fans not operating after fire suppression system testing.</b>				
1	Has fire alarm been cleared and reset in the building?	Yes ⬇️	No ➡️	<b>Fans are shutdown due to fire alarm.</b> Clear fire alarm and reset fire suppression system. Fans will not operate during fire alarm as required by NFPA 13.
2	Have all fault codes been acknowledged and reset on fan control?	Yes ⬇️	No ➡️	<b>One or more fans may have experienced a fault.</b> Refer to list of fault codes on page 26 for detailed descriptions. Acknowledge and reset all faults, then cycle power to fans. Fans will not operate when Op Status code 5 or “Fire Relay” alarms are active. Refer to instructions in the control manual for accessing Op Status code.
3	Were fans installed using PAM-1 electromechanical relays or other electromechanical relays approved by fan manufacturer?	Yes ⬇️	No ➡️	<b>Fire alarm relays may be defective, incorrectly wired, or do not meet required specifications.</b> Replace fire alarm relays with PAM-1 or other approved electromechanical relays. Solid state relays cannot be used.
4	Disconnect fire alarm relay wiring and install jumper wire between ground and enable terminals on the euro connectors of all fans (refer to page 13). Turn fans on using control. Do fans operate as expected?	Yes ⬇️	No ➡️	<b>Contact factory.</b>
5	Remove jumper wire from ground and enable terminals on the euro connectors of all fans (refer to page 13). Turn fans on using control. Do fans operate as expected?	Yes ⬇️	No ➡️	<b>Fire alarm relays and/or fire alarm relay wiring are defective.</b> Replace defective components.
<b>Everything is working properly.</b>				

<b>Problem: One or more fans operated normally for a period of time, but have stopped running.</b>				
1	Have all fault codes been acknowledged and reset on fan control?	Yes ⬇️	No ➡️	<b>One or more fans may have experienced a fault.</b> Refer to list of fault codes on page 26 for detailed descriptions. Acknowledge and reset all faults, then cycle power to fans. Fans will only operate when Op Status code is equal to 0. Refer to instructions in the control manual for accessing Op Status code.
2	Is supply power turned on at all circuit breakers and fan disconnects?	Yes ⬇️	No ➡️	<b>No supply power to fans.</b> Turn circuit breakers and disconnects to “on” position.
3	Are there visible signs of damage on supply power wiring or VFD circuit boards (black marks, damaged components, etc.)?	Yes ⬇️	No ➡️	<b>Damaged or defective VFDs. Contact factory.</b>
4	Do fans operate as expected?	Yes ⬇️	No ➡️	<b>Contact factory.</b>
<b>Everything is working properly.</b>				

## Fault Code Causes and Possible Solutions

Code	Fault	Description	Possible Cause(s)	Solution
0	No Fault	Fan is operating as expected	-	-
1	Modbus Timeout	Inconsistent Modbus RTU communication between control and drive resulting in incorrect fan operation	<ol style="list-style-type: none"> <li>1. Loose CAT-5e cable connections</li> <li>2. Unshielded or damaged CAT-5e cables and RJ45 splitters</li> <li>3. Incorrect network biasing settings</li> <li>4. Incorrect low voltage wiring on euro connector</li> <li>5. Incorrect supply power applied to VFD</li> <li>6. Supply power phase imbalance</li> </ol>	<ol style="list-style-type: none"> <li>1. Verify that all CAT-5e cable connections are fully seated and secure</li> <li>2. Replace cables with the provided networking components (green shielded CAT-5e cables and black shielded 3-way RJ45 splitters) or components that comply with specifications on page 15</li> <li>3. Refer to Fan Networking instructions on pages 16-18</li> <li>4. Refer to Fan Networking instructions on pages 16-18</li> <li>5. Verify that supply voltage is within +/- 10% of the VFD's rated voltage</li> <li>6. Verify that current is consistent across all phases of supply power</li> </ol>
2	NOT USED			
3	Motor Over Temperature	Internal motor temperature exceeds maximum value resulting in reduced fan speed or shutdown	Ambient temperature too high at the ceiling	Allow motor to cool before increasing speed or restarting fan
4	Drive Over Temperature	Internal VFD temperature exceeds maximum value resulting in reduced fan speed or shutdown	Ambient temperature too high at the ceiling	Allow VFD to cool before increasing speed or restarting fan
5	Bus Over Voltage	Internal VFD voltage is higher than expected resulting in fan shutdown	Incorrect supply voltage	Verify that supply voltage is within +/- 10% of the VFD's rated voltage
6	Bus Under Voltage	Internal VFD voltage is lower than expected resulting in fan shutdown	<ol style="list-style-type: none"> <li>1. Incorrect supply voltage</li> <li>2. Rapid power-cycling at circuit breaker</li> </ol>	<ol style="list-style-type: none"> <li>1. Verify that supply voltage is within +/- 10% of the drive's rated voltage</li> <li>2. After turning power off, wait 30-60 seconds before turning power back on</li> </ol>
7	Phase Over Current	Current is higher than expected on at least one phase of supply power resulting in fan shutdown	<ol style="list-style-type: none"> <li>1. Incorrect supply power</li> <li>2. Supply power phase imbalance</li> </ol>	<ol style="list-style-type: none"> <li>1. Verify that supply power meets all power quality requirements on page 14 and that supply voltage is within +/- 10% of the drive's rated voltage</li> <li>2. Verify that current is consistent across all phases of supply power</li> </ol>
8	Microcontroller High Temp	Microcontroller temperature exceeds maximum value resulting in reduced fan speed or shutdown	Ambient temperature too high at the ceiling	Allow VFD to cool before increasing speed or restarting fan
9	Overspeed Fault	Motor speed is greater than maximum allowable speed resulting in reduced fan speed or shutdown	<ol style="list-style-type: none"> <li>1. Incorrect blade count and/or fan size selected in control</li> <li>2. Wind gusts in building</li> </ol>	<ol style="list-style-type: none"> <li>1. Set fan size and blade count to match physical product using instructions in the control manual</li> <li>2. Close overhead doors, etc. or relocate fan</li> </ol>

# Modbus Register List

HVLS fan VFDs are configured for Modbus RTU communication as standard. The Modbus register list is for applications where a building management system (BMS) or field-supplied control are to be used for fan operation. A baud rate of 19200 bps and a device polling delay of 260 ms are recommended for network functionality.

Register	Name	R/W	Retentive	Signed	Format	Range	Default	Description	Detail	
Control	1	Run Command	R/W		x	0,1,2		0=Stop=clear Fault(s); 1=Reverse; 2=Forward; 99=Reset		
	2	Torque Reference	R/W		xxx	1...100		Percentage of full torque. Torque output determines fan speed.		
	3	Operational Status	R		x	0...6		1=Comm CRC errors, 2=Drive Faulted, 3=Motor temp warning, 4=IGBT temp warning, 5=Drive Inhibited (Fire Input), 6=Wind Shut Down active		
	4	Light Control	R/W		xxx	0..100	0	J5 0-10V Output for Optional Light Control (%)	Resets to 0 after power cycle	
	5	External Temperature	R		xxxxx	-400..1100		External Temp (°C) (0.1 unit)	Based off an external 10K @ 25C NTC thermistor	
Fault	6	Last Fault Code	R	R	xxx			Integer code representing fault history	At each fault occurrence, values are shifted to next register and the current fault is displayed in Last Fault Code. Values are retained after power cycle.	
	7	Second Last Fault	R	R	xxx					
	8	Third Last Fault	R	R	xxx					
	9	Fourth Last Fault	R	R	xxx					
	10	Fifth Last Fault	R	R	xxx					
Diagnostics	11	Firmware Version	R	R	xxxxx	1-500		Incremental Version Count		
	12	Operating Hours	R	R	xxxxx	0-65535		Operating hours (driving motor)	MAX 65535	
	13	Motor RPM	R		S xxx	-300...300		Motor RPM (0.1 rpm)		
	14	Voltage, DC Bus	R		xxx	0...1000		Bus Voltage (Volts) (1 units)		
	15	Voltage, Output RMS	R		xxx	0...1000		RMS Modulated Output Voltage (Volts) (1 units)		
	16	Current, Motor RMS	R		xx.x	0...150		RMS Motor current (Amps) (0.1 units)		
	17	Temperature, Motor	R		S xxx.x	-300...1100		Motor Temp (°C) (0.1 units)		
	18	Temperature, Transistor	R		S xxx.x	-400...1250		Transistor Temp (°C) (0.1 units)	Transistor to Heatsink	
	19	Temperature, MCU	R		S xxx.x	-300...1350		MCU Temp (°C) (0.1 units)		
	20	Thermal Speed Derate	R		xxx	0...100		Speed/Torque derate based on overtemp (%)	Thermal regulation (Motor and/or Drive)	
	21	Communication Errors	R		xxx	0-65535		Number of errors since last power cycle	0-65535	
	22	Min Speed	R/W	R	xxx	0...200		Minimum allowable motor RPM for fan model/size		
	23	Max Speed	R/W	R	xxx	0...200		Maximum allowable motor RPM for fan model/size		
	24	Biasing	R/W	R	x	0, 1		0=no bias; 1=680 Ohm pullup/pulldown biasing		
	25	-- Spare --	R				0			
Configuration	26	KEEP ALIVE (WatchDog)	R/W	R	xxxxx	0-65535	30	Seconds	Any message resets; if a timeout occurs, fan will stop (if running)	
	27	MODBUS Serial Speed	R/W		x	0...9	5	Baud Rate Setting (SW2: Pin 7 ON)	0	1200 bps
									1	2400 bps
									2	4800 bps
									3	9600 bps
									4	19200 bps
									5	38400 bps
									6	57600 bps
7	115200 bps									
28	Motor Type	R/W			0..2	0	13,70,170	0=13; 1 = 70; 2=170		
29	MODBUS Device ID	R/W	R		1-247	2	New Device ID is set after power cycle			
30	-- Spare --	R/W				0				

NOTE: Registers 1000-1150 are reserved for internal Diagnostics and Testing.

# Maintenance Log

---

Date \_\_\_\_\_ Time \_\_\_\_\_ AM/PM

Notes: \_\_\_\_\_

\_\_\_\_\_

\_\_\_\_\_

\_\_\_\_\_

Date \_\_\_\_\_ Time \_\_\_\_\_ AM/PM

Notes: \_\_\_\_\_

\_\_\_\_\_

\_\_\_\_\_

\_\_\_\_\_

Date \_\_\_\_\_ Time \_\_\_\_\_ AM/PM

Notes: \_\_\_\_\_

\_\_\_\_\_

\_\_\_\_\_

\_\_\_\_\_

Date \_\_\_\_\_ Time \_\_\_\_\_ AM/PM

Notes: \_\_\_\_\_

\_\_\_\_\_

\_\_\_\_\_

\_\_\_\_\_

Date \_\_\_\_\_ Time \_\_\_\_\_ AM/PM

Notes: \_\_\_\_\_

\_\_\_\_\_

\_\_\_\_\_

\_\_\_\_\_

Date \_\_\_\_\_ Time \_\_\_\_\_ AM/PM

Notes: \_\_\_\_\_

\_\_\_\_\_

\_\_\_\_\_

\_\_\_\_\_

Date \_\_\_\_\_ Time \_\_\_\_\_ AM/PM

Notes: \_\_\_\_\_

\_\_\_\_\_

\_\_\_\_\_

\_\_\_\_\_

Date \_\_\_\_\_ Time \_\_\_\_\_ AM/PM

Notes: \_\_\_\_\_

\_\_\_\_\_

\_\_\_\_\_

\_\_\_\_\_

## Our Commitment

---

*As a result of our commitment to continuous improvement, Venco reserves the right to change specifications without notice.*



Phone: 1.833.881.0565 • Fax: 715.355.2399 • E-mail: [info@vencoproducts.com](mailto:info@vencoproducts.com) • Website: [www.vencoproducts.com](http://www.vencoproducts.com)