

## Installation, Operation and Maintenance Manual

Please read and save these instructions for future reference. Read carefully before attempting to assemble, install, operate or maintain the product described. Protect yourself and others by observing all safety information. Failure to comply with these instructions will result in voiding of the product warranty and may result in personal injury and/or property damage.

These instructions describe the installation of a CRD-1WJ in designs: L501, L502, L503, L506, L507, L508, L512, L513, L514, L515, L516, L517, L519, L522, L523, L533, L537, L545, M530, M538, and M563 as detailed in the UL Fire Resistance Directory.

Number	Description
1	Flooring Systems
2	Wood Joists
3	Cross Bridging
4	CRD-1WJ Assembly (damper, steel box, & insulation)
5	Mounting angle
6	Gypsum board (see UL Fire Resistance Directory for type)
7	Finishing System (not shown)
8	Grille

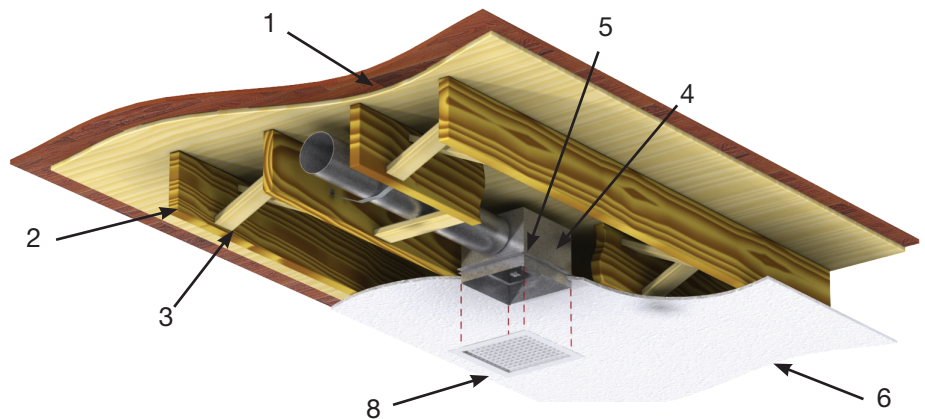

Figure 1

### Receiving and Handling

Upon receiving dampers, check for both obvious and hidden damage. If damage is found, record all necessary information on the bill of lading and file a claim with the final carrier. Check to be sure that all parts of the shipment, including accessories, are accounted for.

Dampers must be kept dry and clean. Indoor storage and protection from dirt, dust and the weather is highly recommended. Do not store at temperatures in excess of 100°F (38°C).

### Safety Warning

Improper installation, adjustment, alteration, service or maintenance can cause property damage, injury or death. Read the installation, operating, and maintenance instructions thoroughly before installing or servicing this equipment.

### General Information

“UL CLASSIFIED (see complete marking on product)”

“UL CLASSIFIED to Canadian safety standards (see complete marking on product)”

Standard 555C (Listing #R13446)

This manual is the property of the owner and is required for future maintenance. Please leave it with the owner when the jobs is complete.

## Pre-Installation Guidelines

The following items will aid in completing the damper installation in a timely and effective manner.

- 1) Check the drawings for proper damper locations within the building. Visually inspect the damper for damage. CRD-1WJ are shipped from the factory with blades in the closed position. The fusible link must be installed at the time of installation such that the blades are held open as shown in **Figure 2**.
- 2) Lift or handle damper using sleeve or frame. Do not lift damper using blades.
- 3) Fasteners (screws, bolts, rivets, etc.) used for installation must not interfere with blade operation.
- 4) Flexible duct must be Class 1 or 0 type, bearing the UL listed mark. Steel duct must be a minimum 28 ga. (0.5mm) and maximum 20 ga. (1 mm).
- 5) Ceiling damper must be installed as described in these installations.
- 6) Ceiling penetration shall be located between floor/ceiling joists.
- 7) The CRD-1WJ supplied without a factory supplied plenum box require a steel plenum to be field installed (see page 8).
- 8) Dampers shipped with factory attached plenums **MUST** be installed prior to sheetrock ceiling installation
- 9) Dampers must be installed into opening and free of twist or other misalignment. Out of square, racked, twisted, or misaligned installation can cause excessive leakage.
- 10) Dampers must be kept clean and protected from dirt, dust and other foreign materials prior to and after installation. Examples of such foreign materials include but are not limited to:
  - a) Mortar dust
  - b) Drywall dust
  - c) Firesafing materials
  - d) Wall texture
  - e) Paint overspray
- 11) Damper should be sufficiently covered as to prevent overspray if wall texturing or spray painting will be performed within 5 feet of the damper. Excessive dirt or foreign material deposits on the damper can cause excessive leakage and/or torque requirements to exceed damper/actuator design.

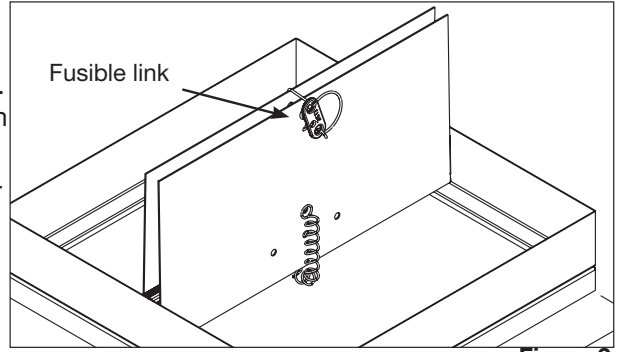

## Installation

The damper assembly is to be attached to the joists using 2 - 1 in. x 1/2 in. x 20 ga. (25 mm x 13 mm x 1 mm) mounting angles. See **Figure 3**.

- 1) Attach the mounting angles to the damper box on the sides of the box without the supplied flanges. Attach the mounting angles 5/8 in. (16 mm) above using minimum #8 sheet metal screws or 3/16 in. (5 mm) angle and a maximum of 2 in. (51 mm) from the corner of the box.
- 2) Insert the damper assembly, with attached mounting angles, between ceiling joists and attach to joists using minimum 2 - #8 x 3/4 in. (19 mm) nails per side - see **Figure 4 & 5**.

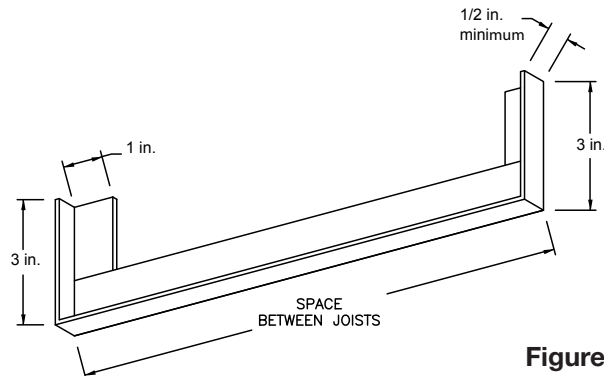

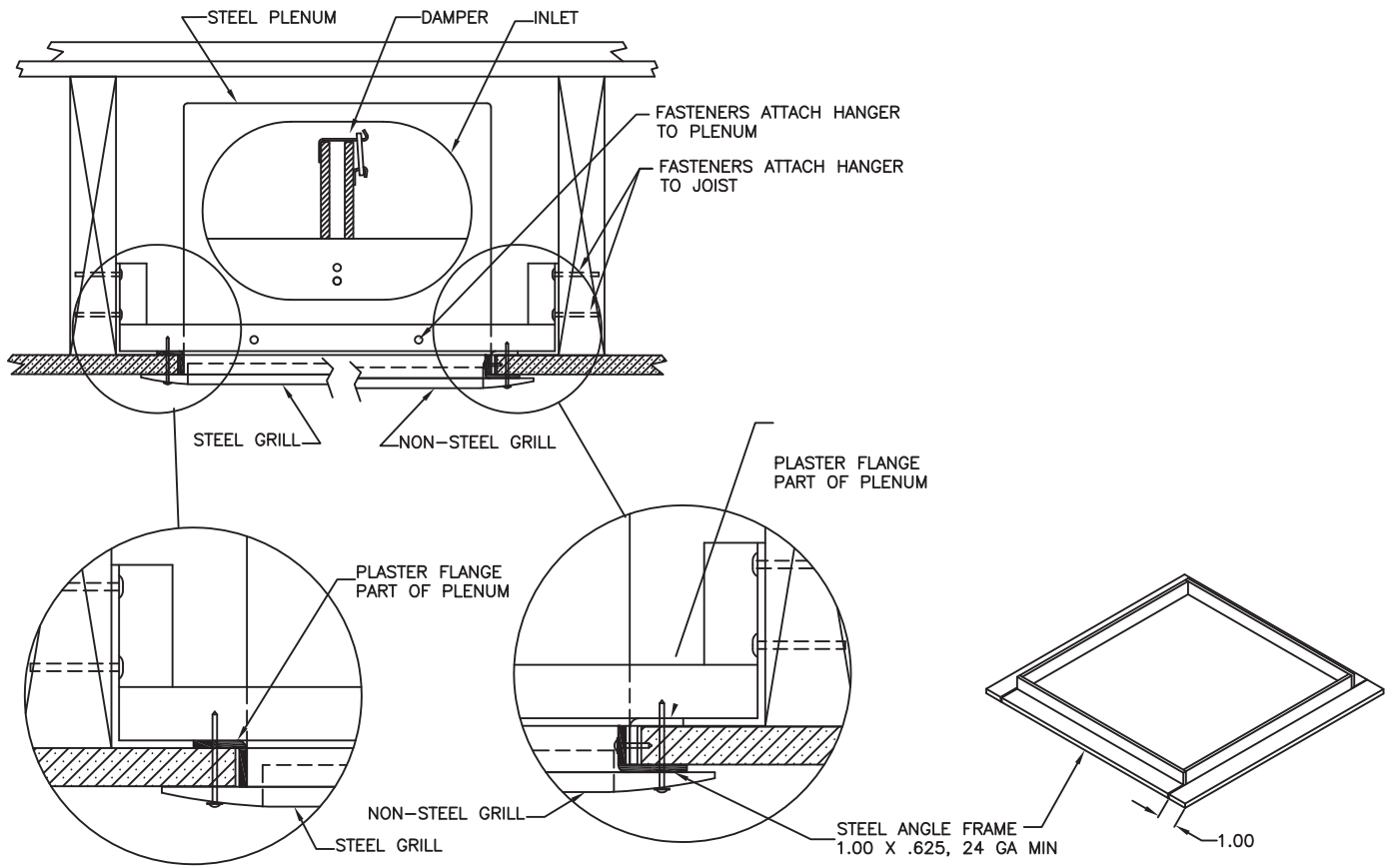

Figure 4

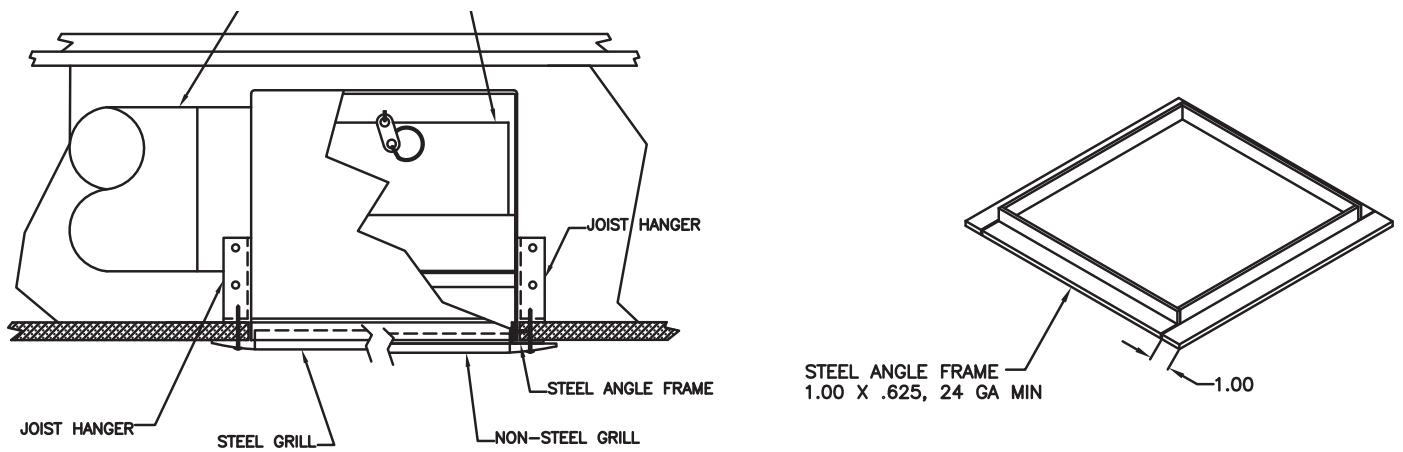

Figure 5

## Field Installation of Steel Plenums for CRD-1WJ

- 1) The steel plenum box shall be a minimum of 24 ga. (0.7 mm) of galvanized steel.
- 2) The inside width x length dimensions of the steel plenum shall be sized no greater than  $\frac{1}{8}$  in. (3 mm) larger than the damper frame. The maximum plenum height shall be  $8\frac{5}{8}$  in. (219 mm). The plenum should be sized to provide a snug fit over the damper frame.
- 3) The plenum duct collars shall be a minimum of 24 ga. (0.7 mm) galvanized steel. The total area of the plenum box duct collars shall not exceed 59.5 sq. in. (1511 sq. mm) with a maximum of two duct collars per plenum. Duct collars shall be securely fastened to the plenum surface. Any segment of the duct collar that protrudes inside the plenum wall must not interfere with the damper blade operation.
- 4) The steel plenum box is to be attached to the damper using #8 screws,  $\frac{1}{8}$  in. (3 mm) rivets, spot welds, or tack welds. Minimum of two per side (**Figure 6 and 7**).
- 5) The attachment of the screws or rivets must not interfere with the damper operation.

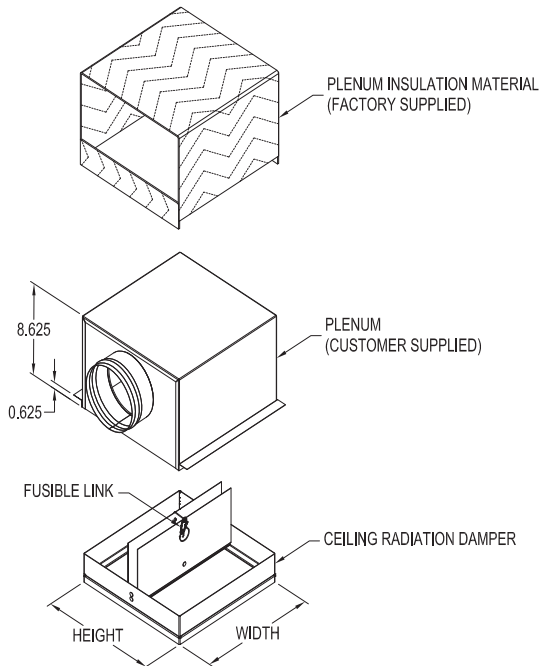

Figure 6: Exploded view

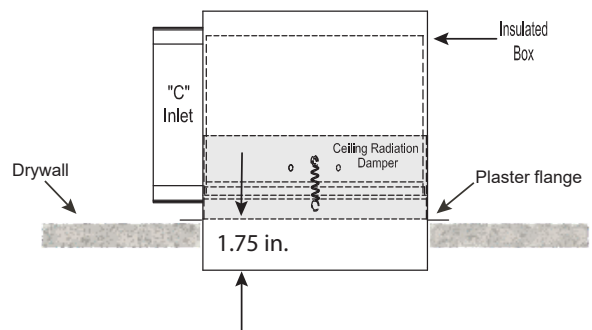

Figure 7: Assembled view

## Damper Maintenance

Dampers do not typically require maintenance as long as they are kept dry and clean. If cleaning is necessary, use mild detergents or solvents. If lubrication is desired for components, such as axle bearings, do not use oil-based lubricants or any other lubricants that attract contaminants such as dust.

Dampers and their actuator(s) must be maintained, cycled, and tested a minimum in accordance with:

- The latest editions of NFPA 80, 90A, 92A, 92B, 101, 105, UL864, AMCA 503-03, and local codes.

## Our Commitment

*As a result of our commitment to continuous improvement, Venco reserves the right to change specifications without notice.*



Phone: 1.833.881.0565 • Fax: 715.355.2399 • E-mail: info@vencoproducts.com • Website: www.vencoproducts.com