

Wiring Diagrams: FSKN120-BAC

RRL

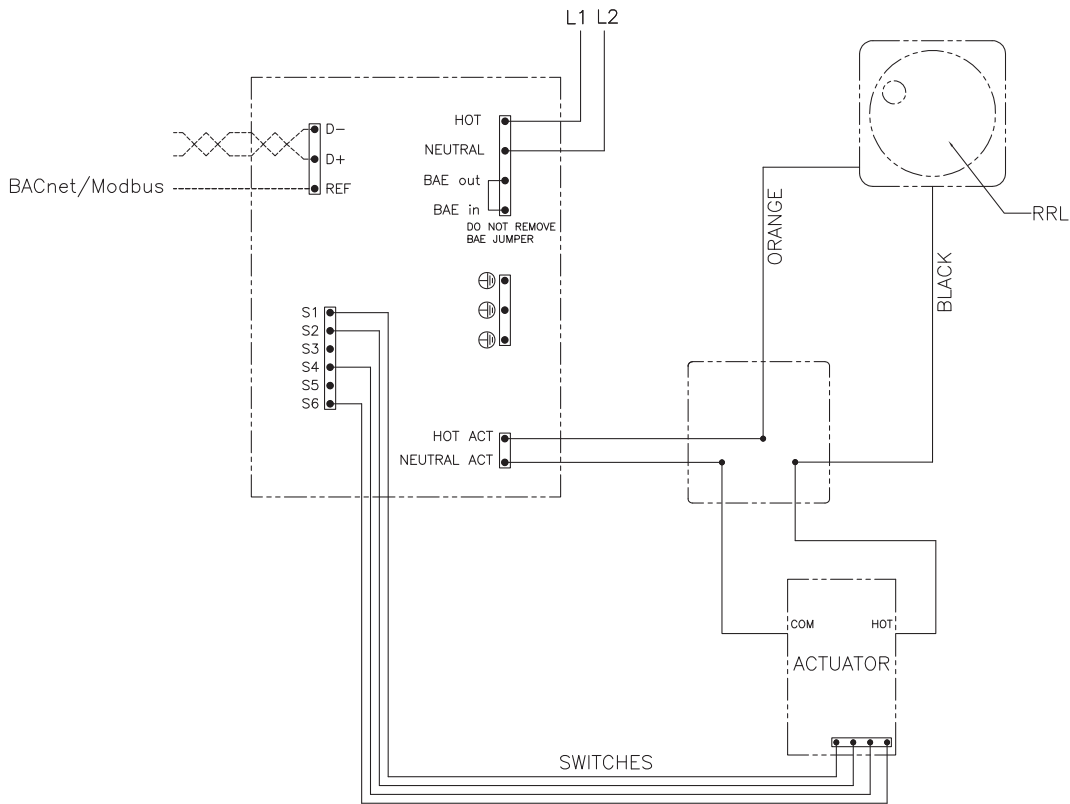

RRL with no flow smoke detector

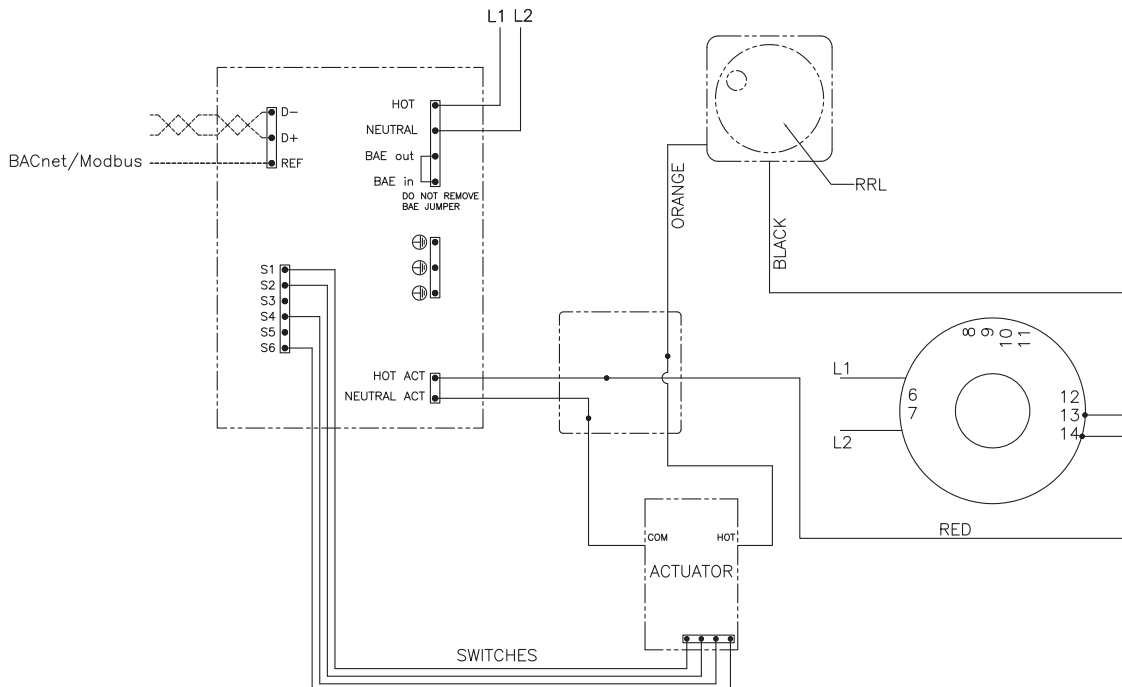

Wiring Diagrams: FSKN120-BAC

RRL with Low Flow Smoke Detector

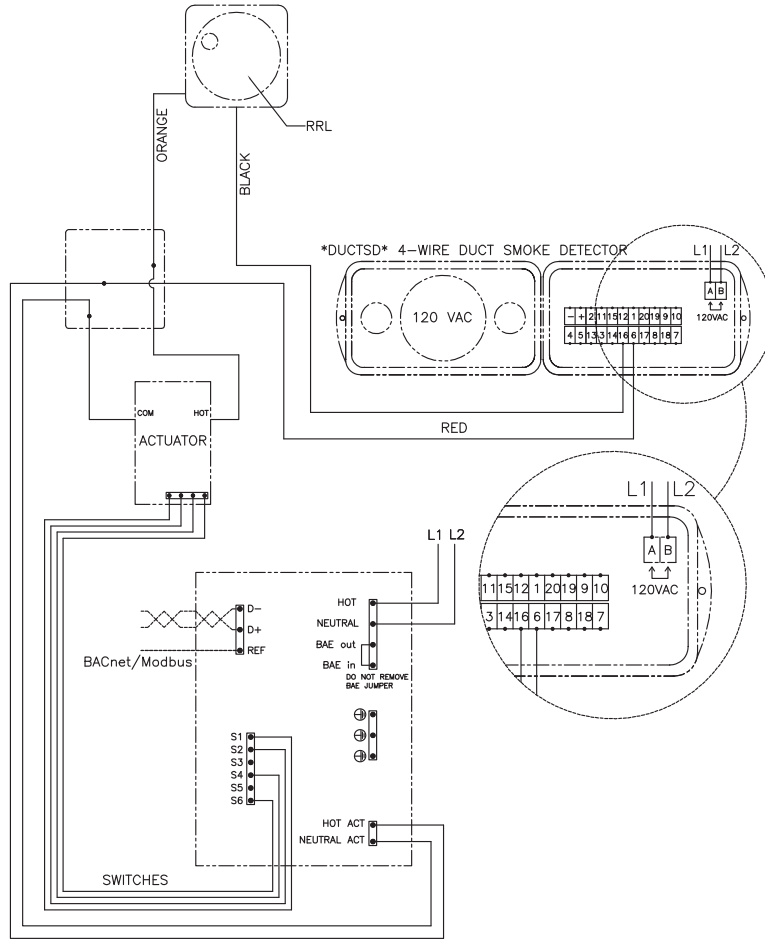

RRL/OCI

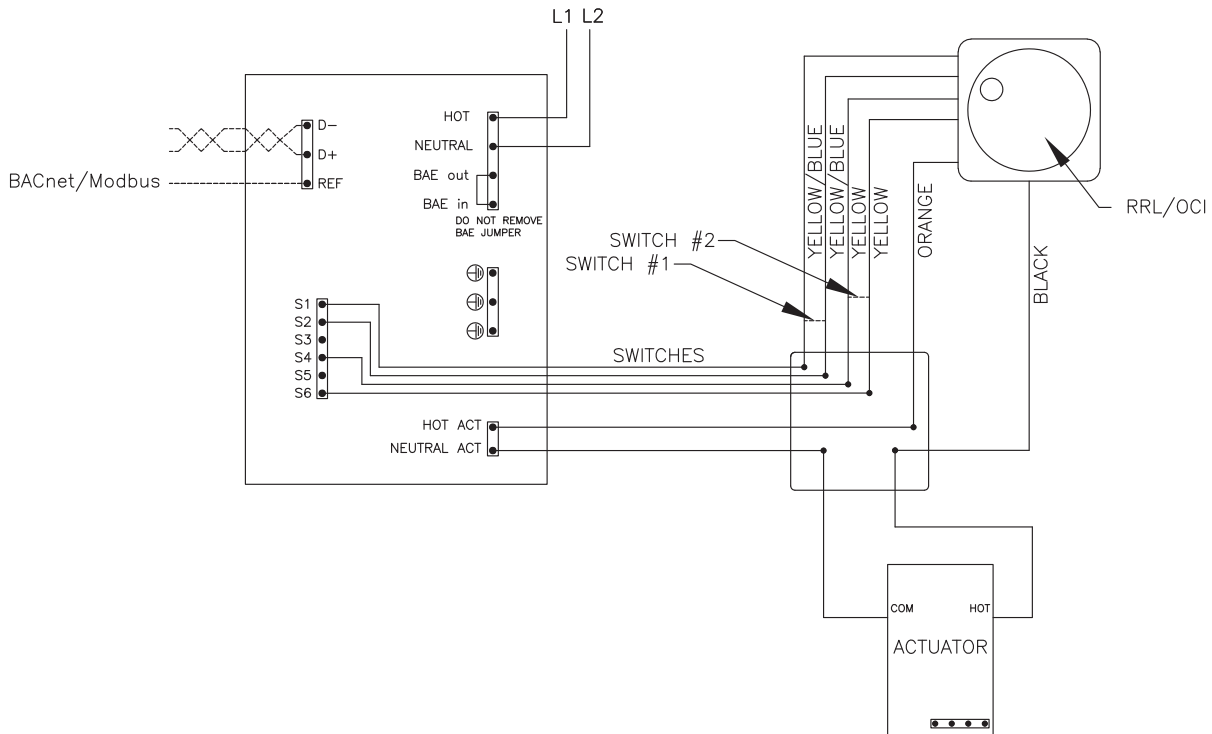

Wiring Diagrams: FSKN120-BAC

RRL/OCI with no flow smoke detector

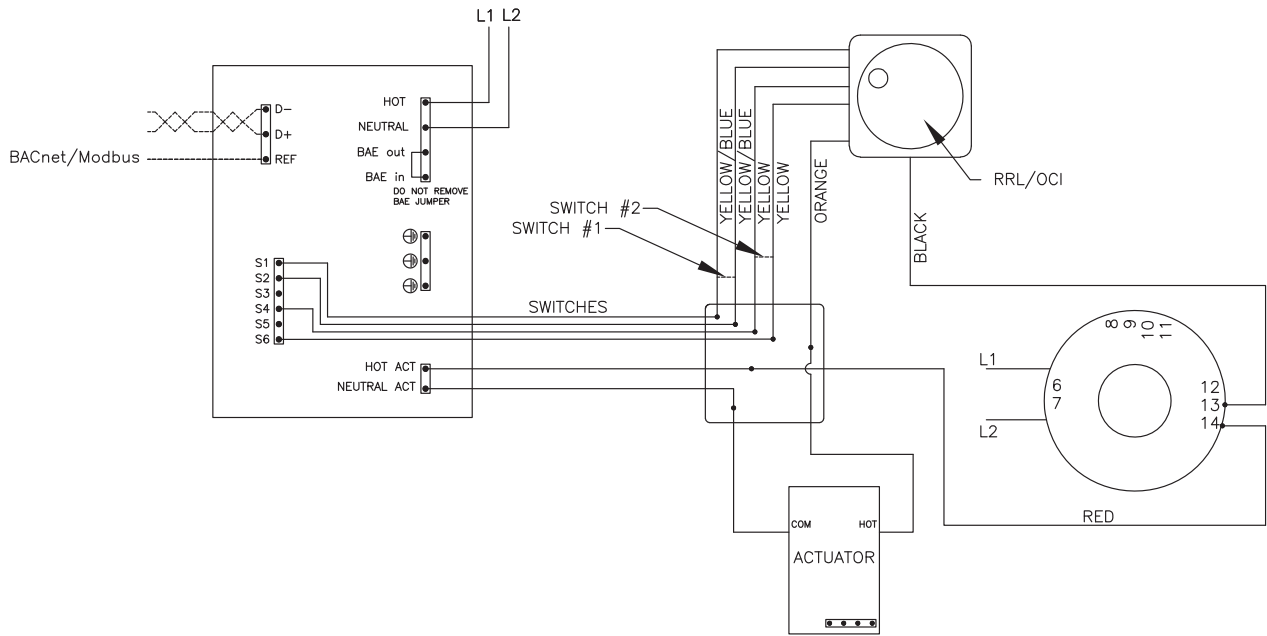

RRL/OCI with low flow smoke detector

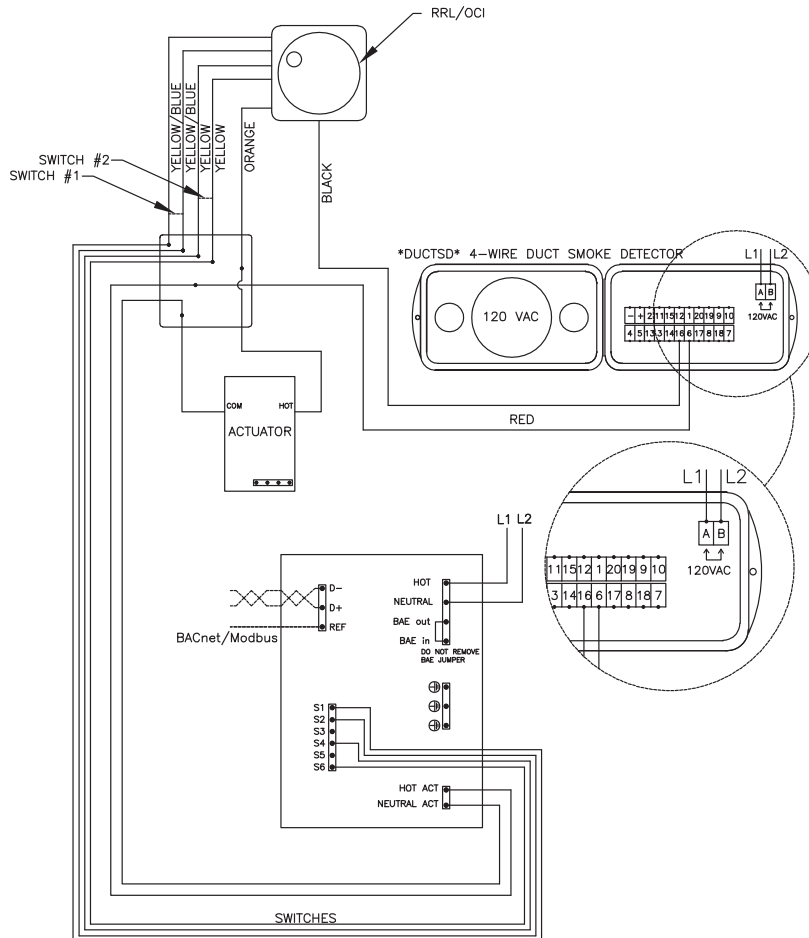

Wiring Diagrams: FSKN120-BAC

OCI

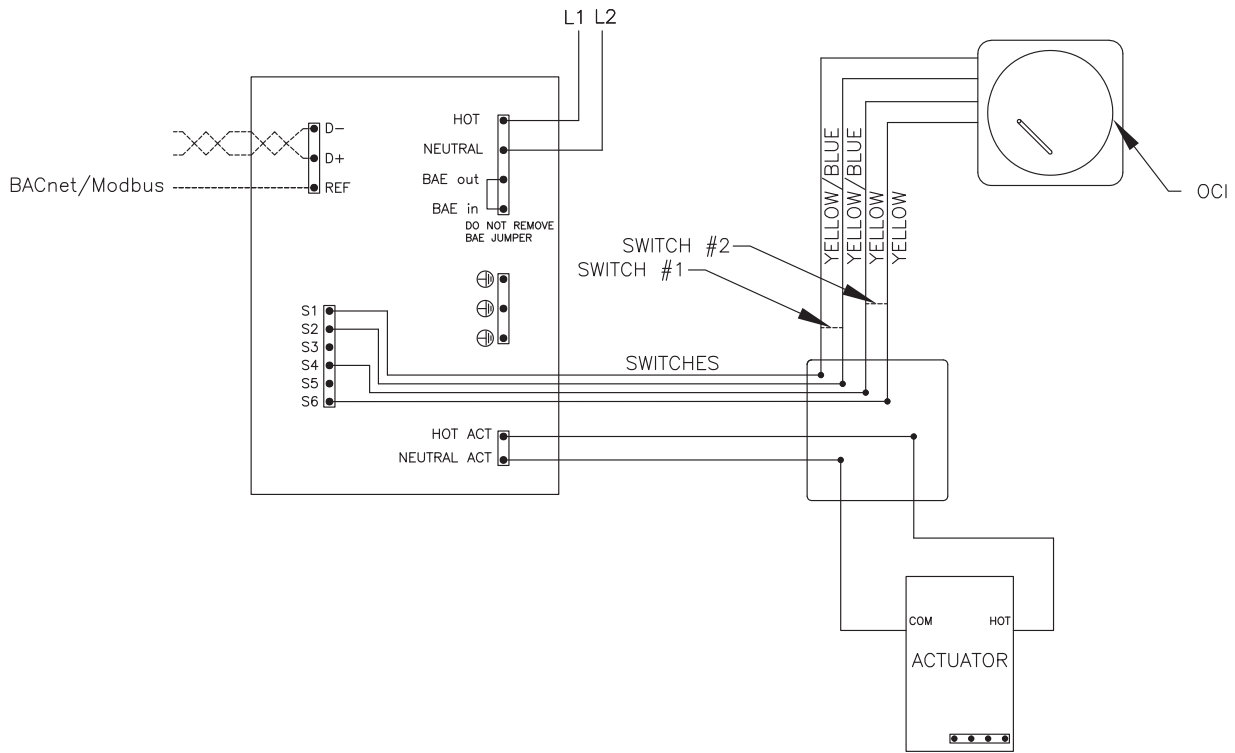

OCI with no flow smoke detector

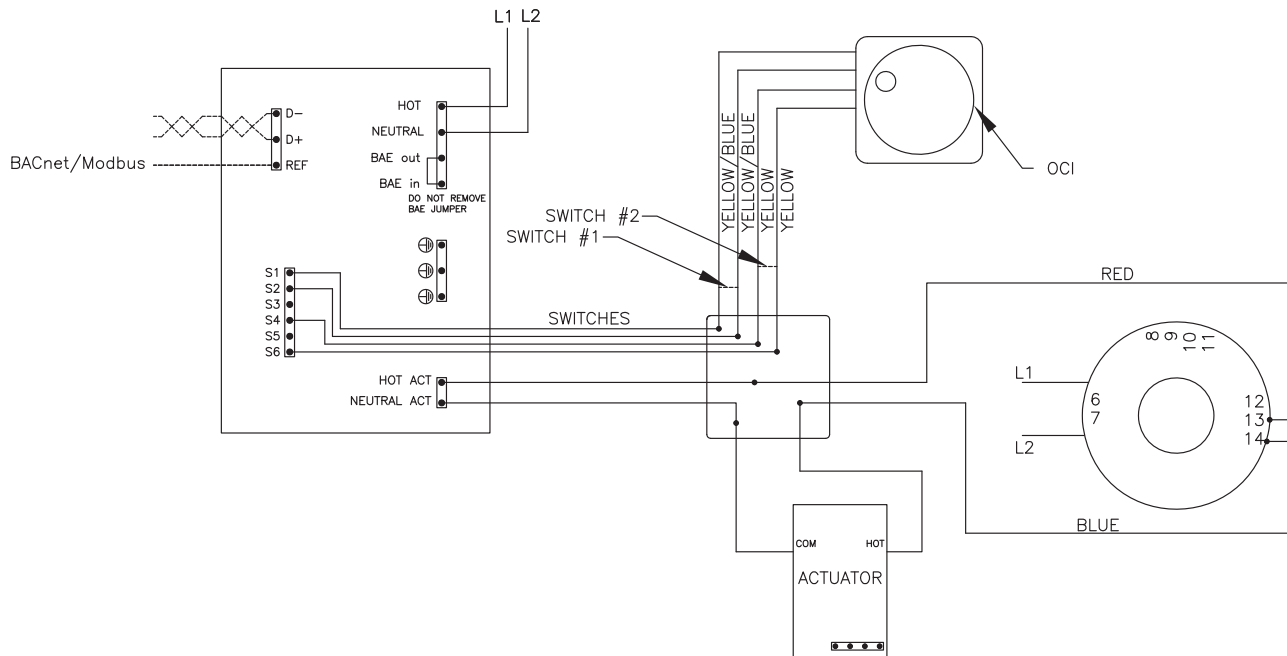

Wiring Diagrams: FSKN120-BAC

OCI with low flow smoke detector

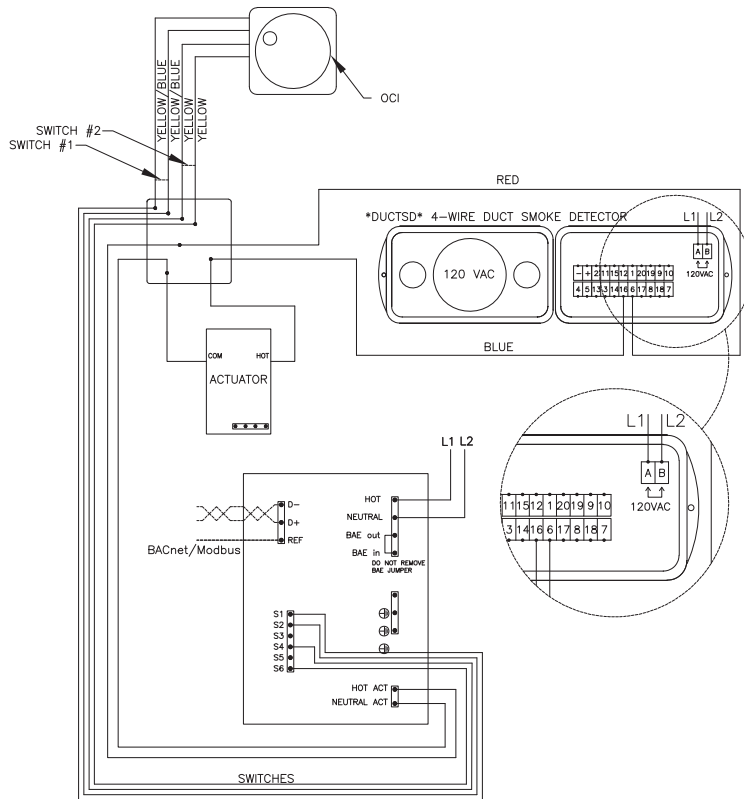

Wiring Diagrams: FSKN24-BAC

RRL

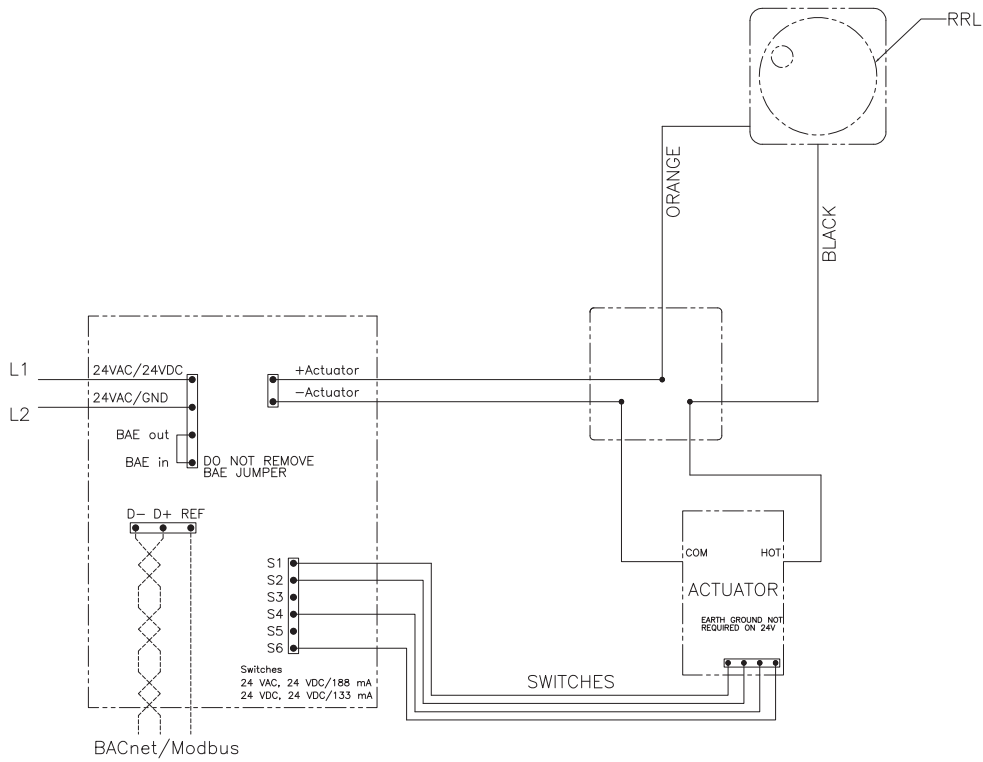

RRL with no flow smoke detector

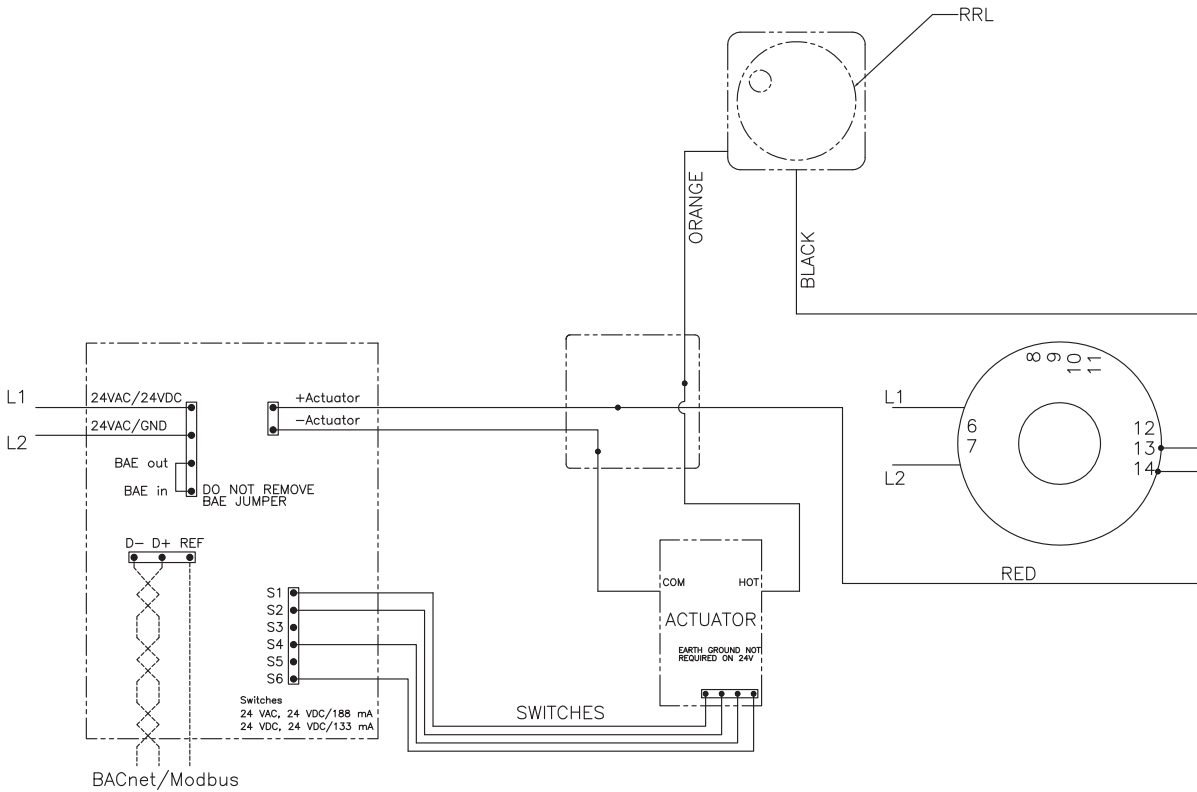

Wiring Diagrams: FSKN24-BAC

RRL with low flow smoke detector

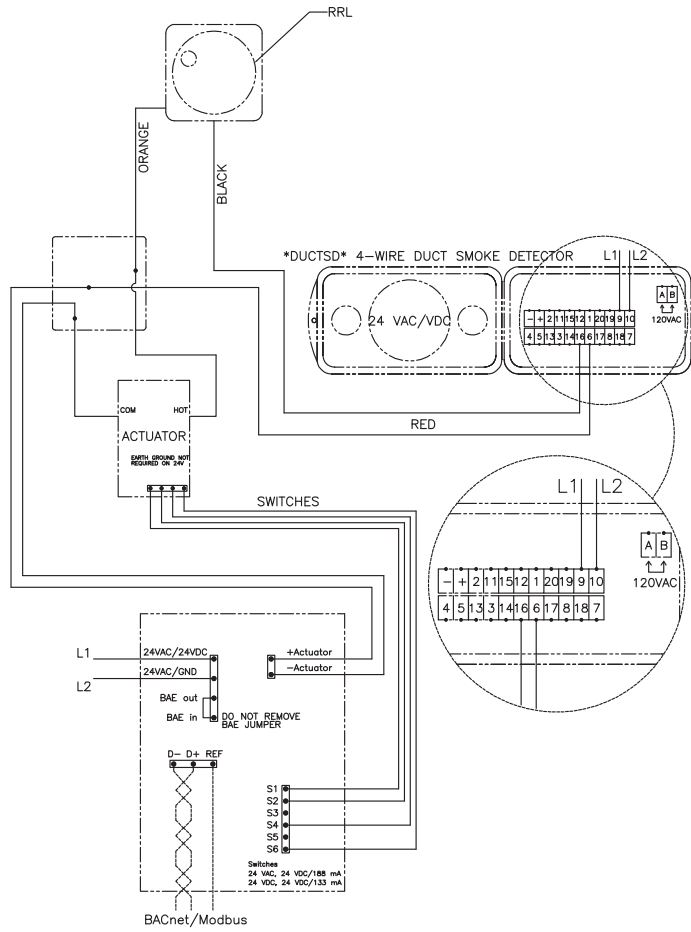

RRL/OCI

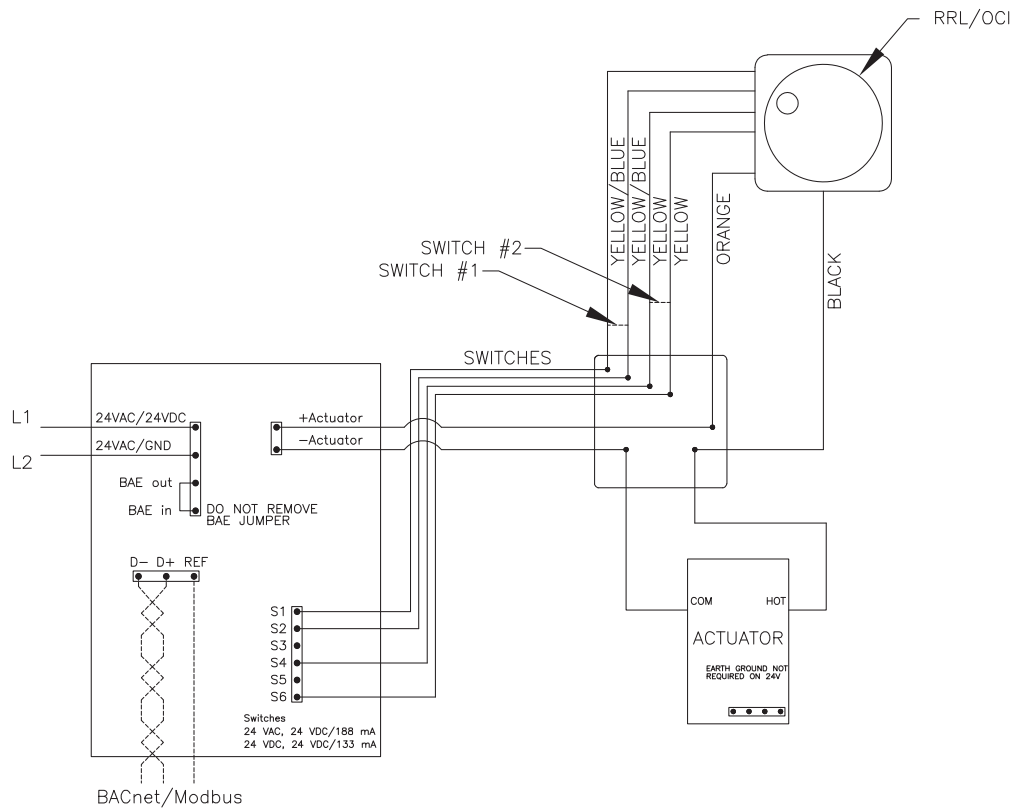

Wiring Diagrams: FSKN24-BAC

RRL/OCI with no flow smoke detector

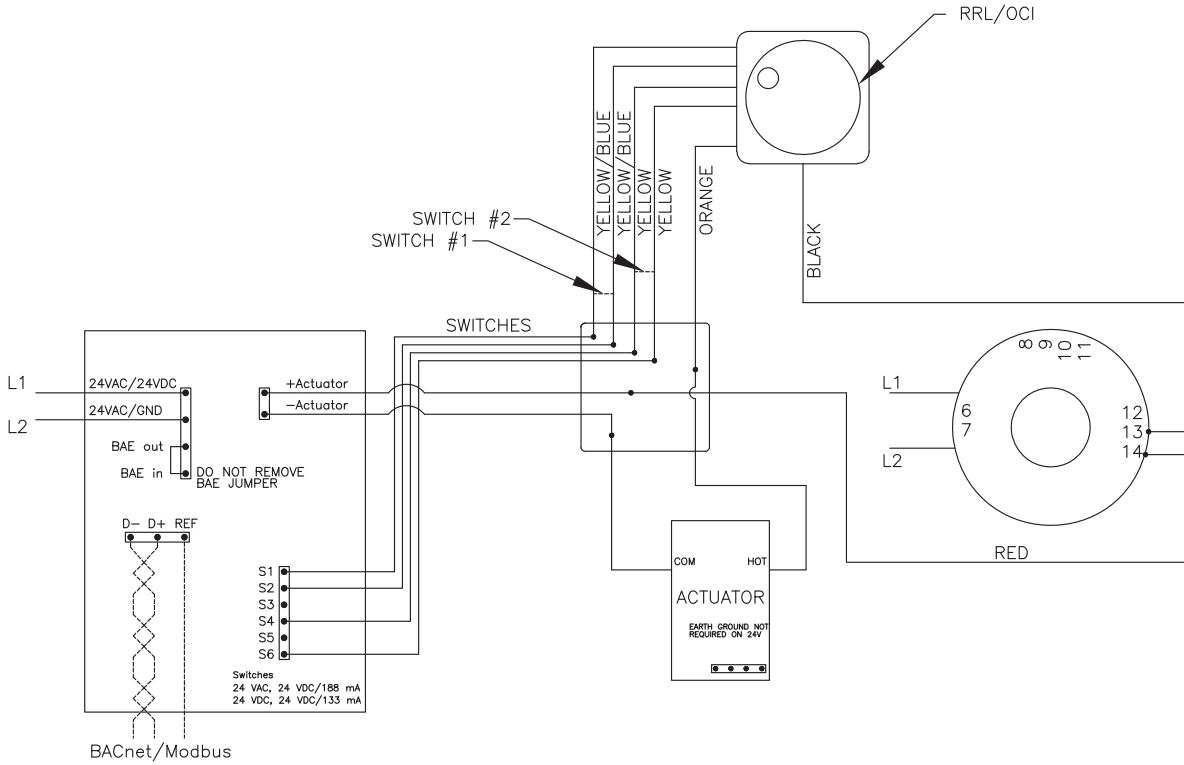

RRL/OCI with low flow smoke detector

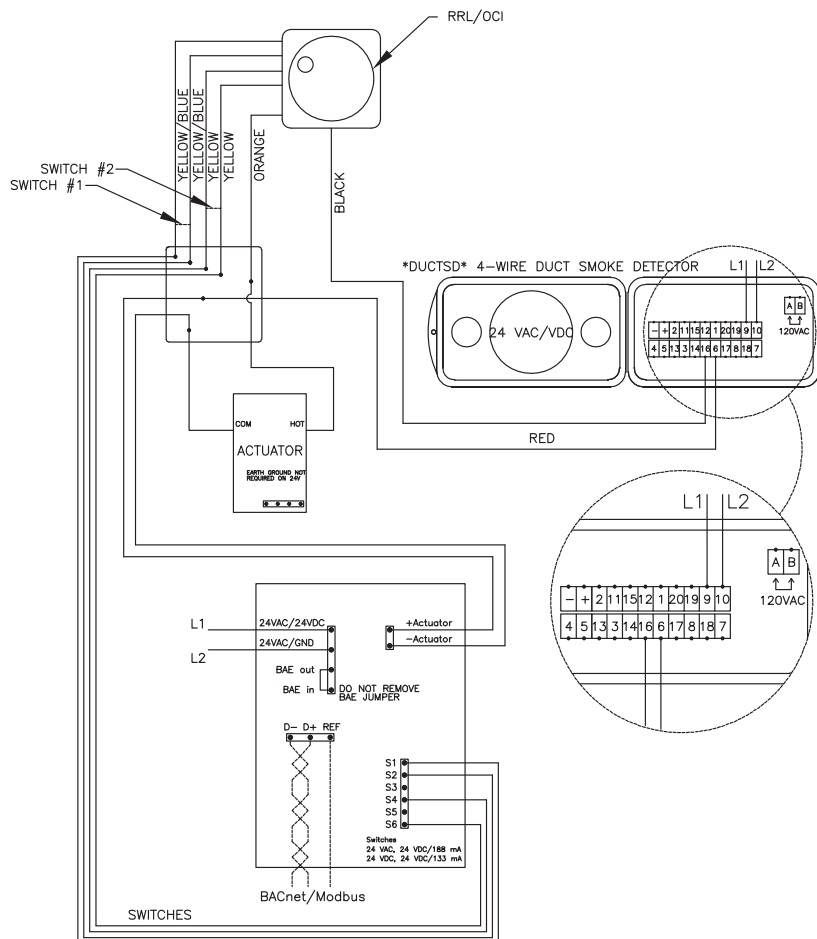

Wiring Diagrams: FSKN24-BAC

OCI

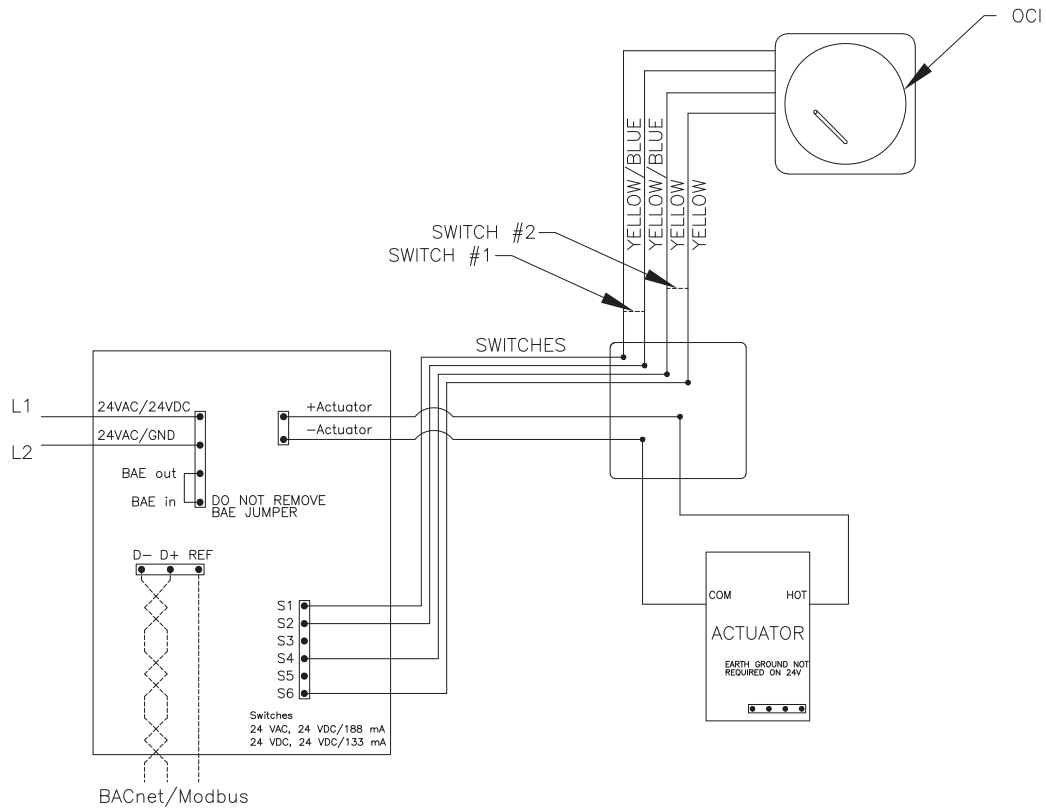

OCI with no flow smoke detector

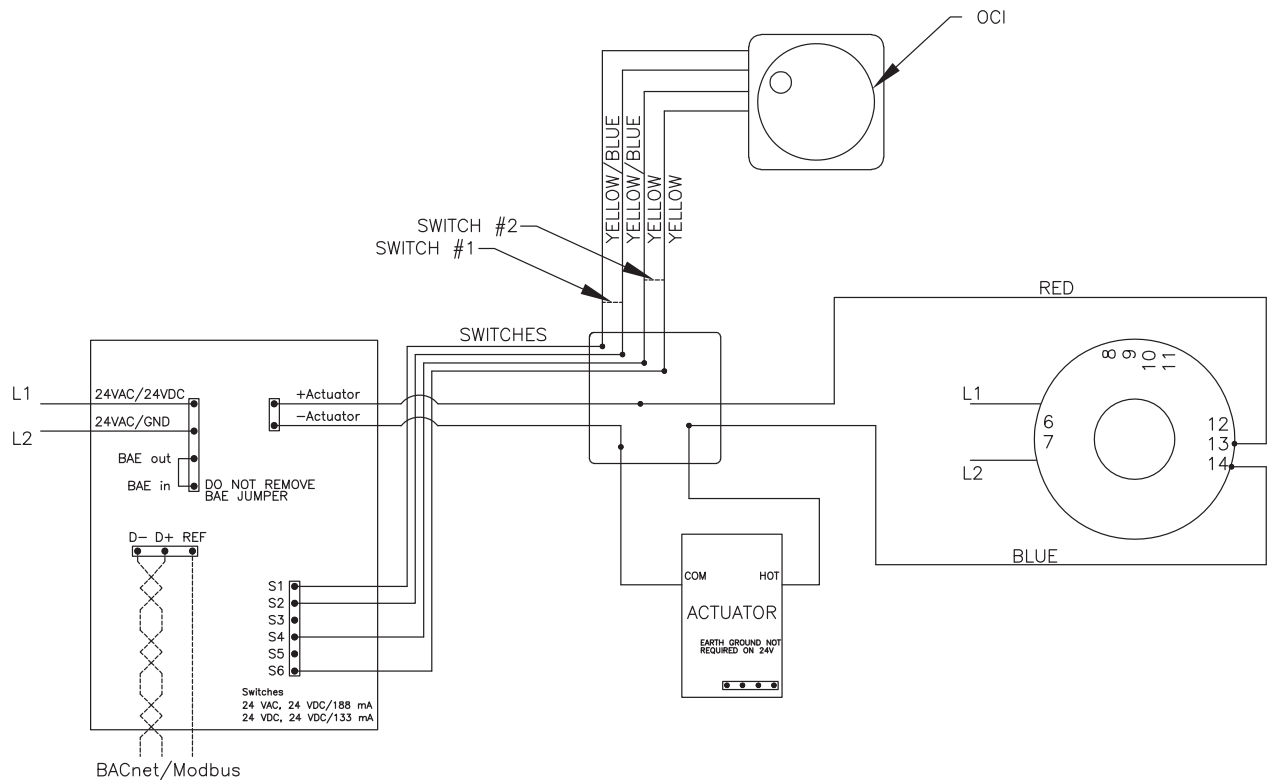

Wiring Diagrams: FSKN24-BAC

OCI with low flow smoke detector

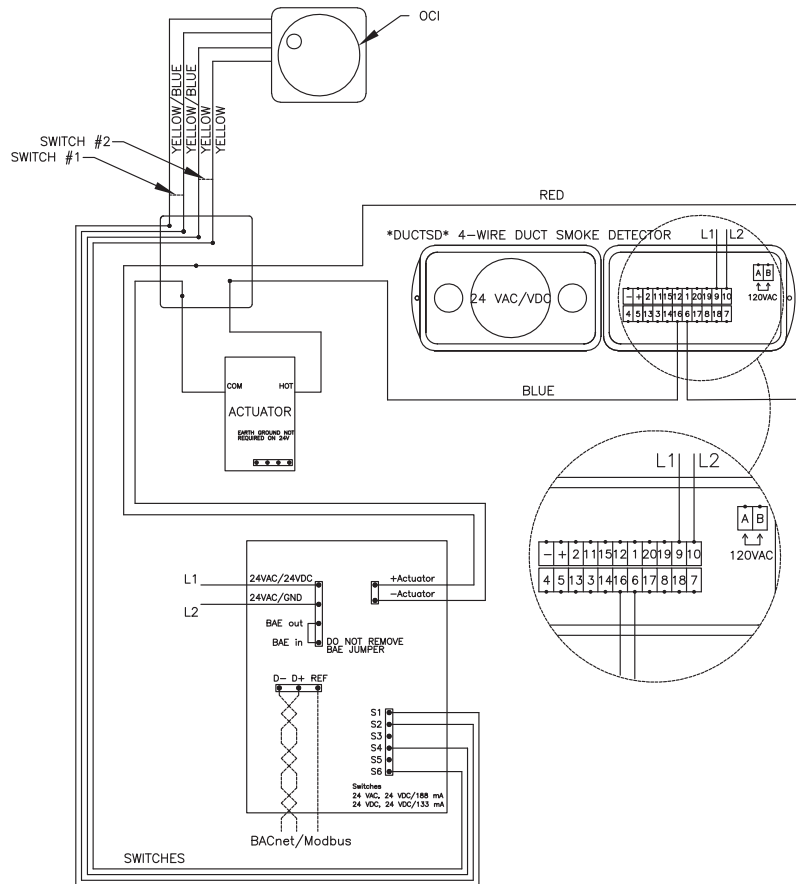

Reference links to Belimo:

[Installation Instructions](#)

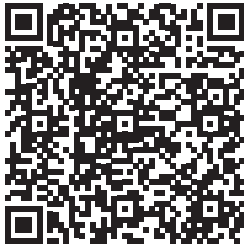

[FSKN Application Guide](#)



[FSKN BACnet & Modbus Information](#)



Our Commitment

As a result of our commitment to continuous improvement, Venco Products reserves the right to change specifications without notice.



Phone: 1.833.881.0565 • Fax: 715.355.2399 • E-mail: info@vencoproducts.com • Website: www.vencoproducts.com