

Actuator mounting and hardware requirements vary based on the specific damper configuration. This supplement will provide general guidelines on factory and field requirements. Refer to your specific damper configuration and damper drive arrangement supplement for details. Consult factory for specific mounting and hardware information when required.

For vertical blade damper models, the blades would run vertically and the actuator would be on the top or bottom.

### Factory Actuator

A factory furnished actuator may be ordered from Greenheck installed directly on the damper or as an actuator kit (for field installation). Right hand (standard) and left hand (optional) mounting is available in all mounting styles.

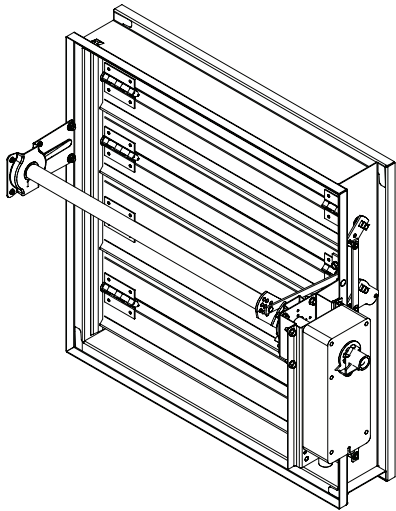

**Jackshaft external (right)** includes actuator and mounting hardware. Typically extend 6¼ inches beyond the frame. For specific actuator model information, see control damper submittals.

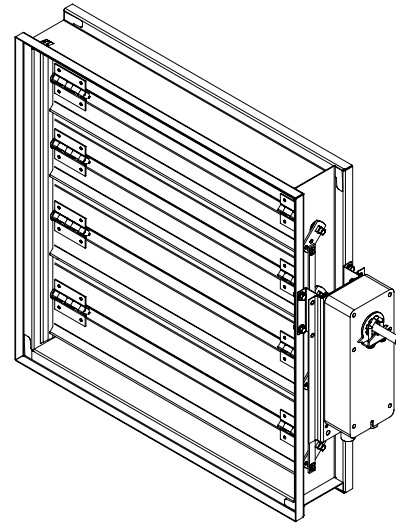

**Non-jackshaft external (right)** includes actuator and mounting hardware

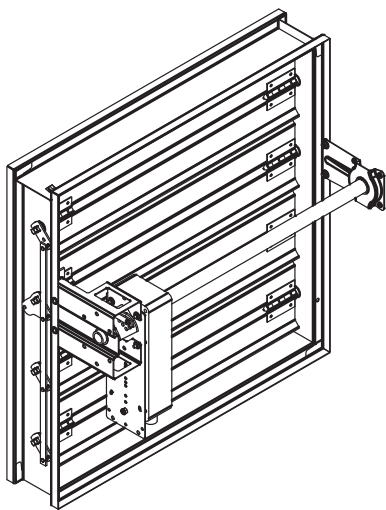

**Jackshaft internal (left)** includes actuator and mounting hardware. Components will not extend past the perimeter of the frame. Actuator is in the airstream.

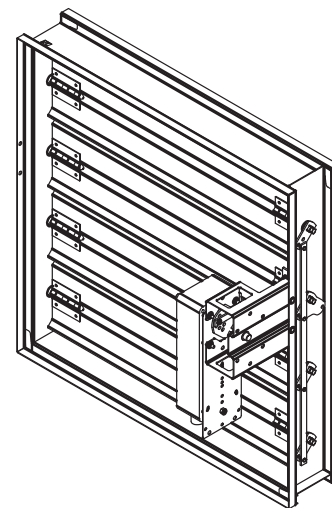

**Non jackshafted internal (right)** includes actuator and mounting hardware. Actuator is in the airstream.

## Factory Actuator

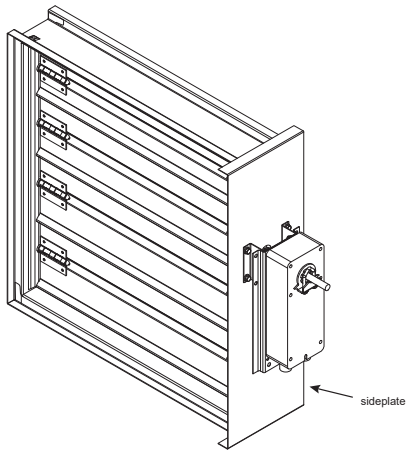

**Sideplate external (right)** includes sideplate, actuator and mounting hardware. Typically extends  $6\frac{1}{4}$  inches beyond the frame. See control damper submittals for specific actuator model information.

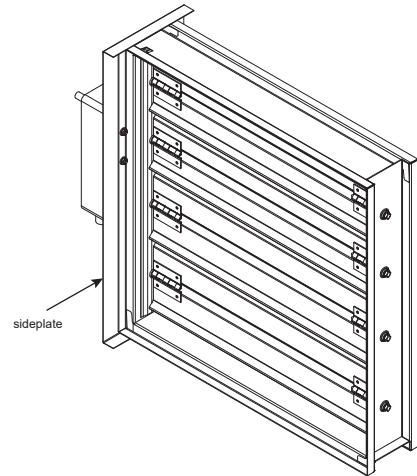

**Sideplate external (left)** includes sideplate, actuator, and mounting hardware.

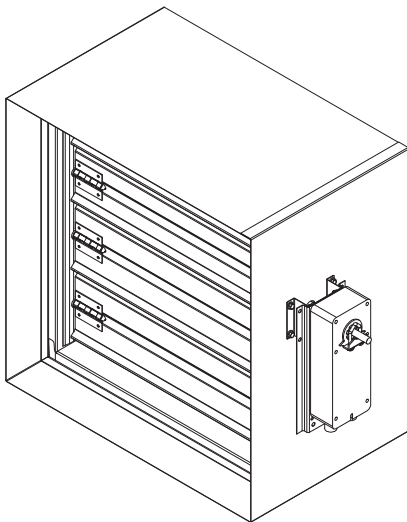

**Sleeve external (right)** includes damper sleeve, actuator, and mounting hardware. See control damper submittals for specific actuator model information.

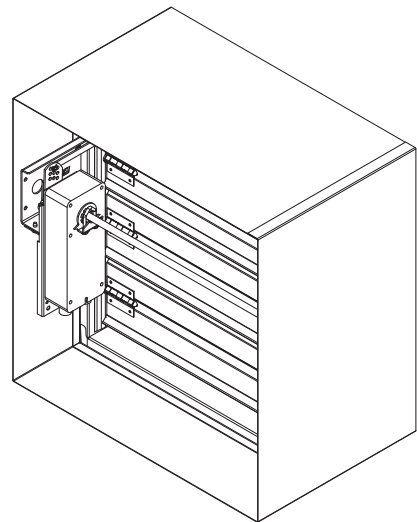

**Sleeve internal (left)** includes sleeve, actuator, mounting hardware. Actuator is in the airstream.

**Note:** Dampers with transitions are configured the same as dampers with sleeves.

## Customer Supplied Actuator

For dampers that ship with factory-mounted actuators, jackshafts are provided as ½ or 1 inch, damper configuration dependent. For customer supplied actuators, jackshaft, if required, will always be furnished with a 1 in. diameter jackshaft. Right hand (standard) and left hand (optional) mounting is available in all mounting styles.

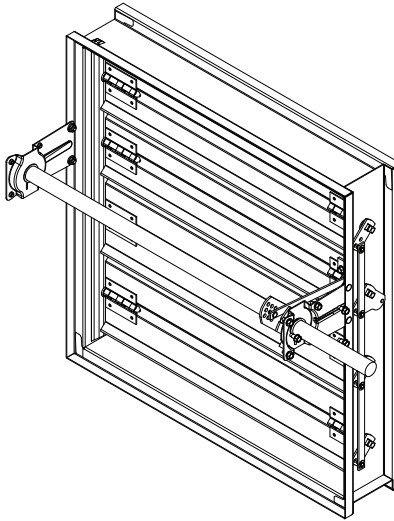

**Jackshaft external (right)** includes crankarm assembly and jackshaft, no actuator mounting hardware.

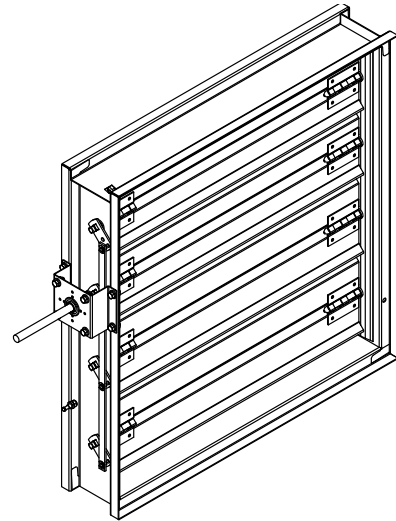

**Non-jackshafted external (left)** includes extension pin. Standoff bracket is optional.

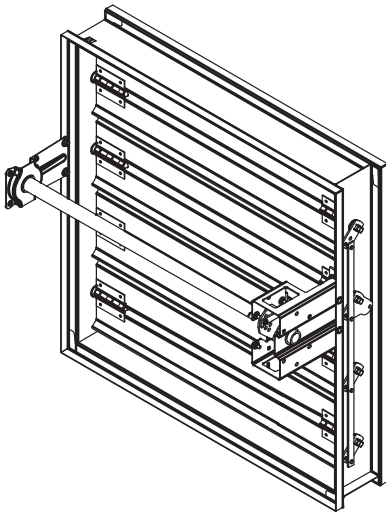

**Jackshaft internal (right)** includes crankarm assembly and jackshaft, no actuator mounting hardware. Actuator is in the airstream.

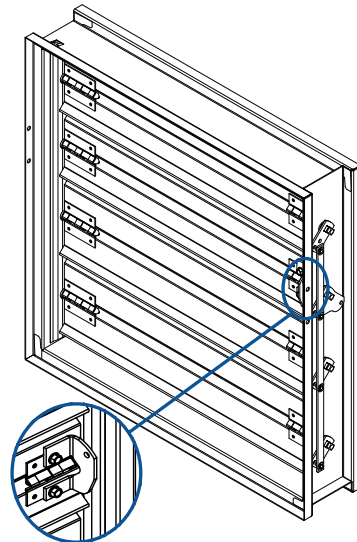

**Non-jackshaft internal (right)** includes blade lever, no actuator mounting or linkage hardware provided. Not recommended for direct drive actuators.

## Bracket Only

Our standard factory provided bracket works with most commercially available direct drive actuators. Right hand (standard) and left hand (optional) mounting is available in all mounting styles.

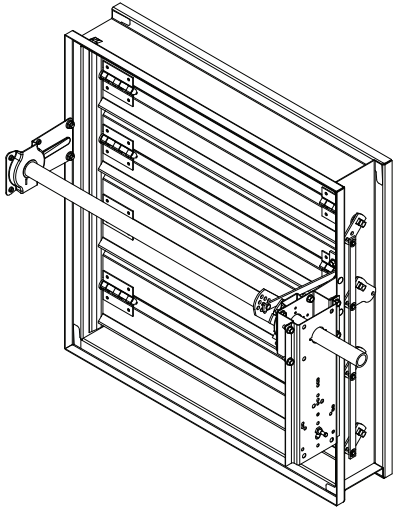

**Jackshaft external (right)** includes actuator mounting bracket

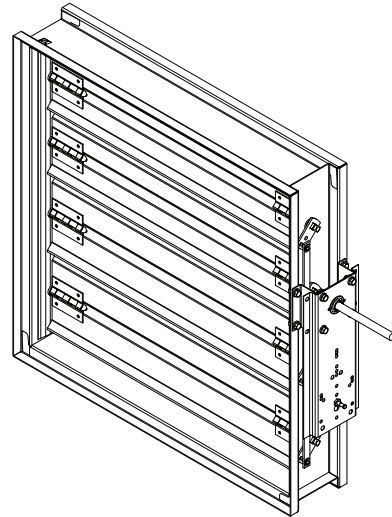

**Non-jackshafted external (right)** includes actuator mounting bracket

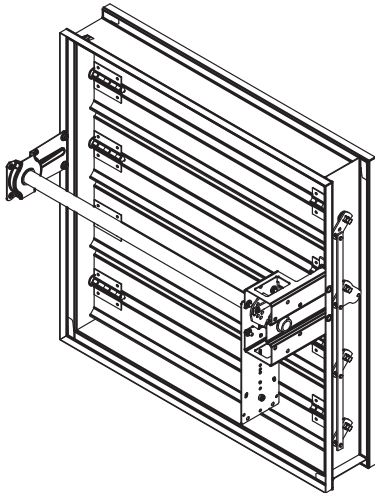

**Jackshaft internal (right)** includes actuator mounting bracket

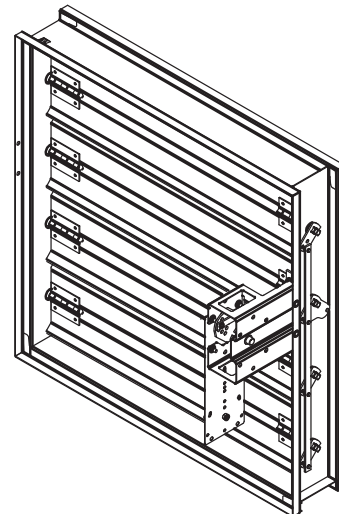

**Non-jackshafted internal (right)** includes actuator mounting bracket

## Mounting Orientation

---

Control dampers are rated for airflow in both directions which allows the damper to be mounted in any position with the blades horizontal. The damper can be rotated so the actuator is on the left or right side.

For vertical blade damper models, the blades would run vertically and the actuator would be at the top or bottom.



Rotate the damper from left hand to right hand and vice versa.

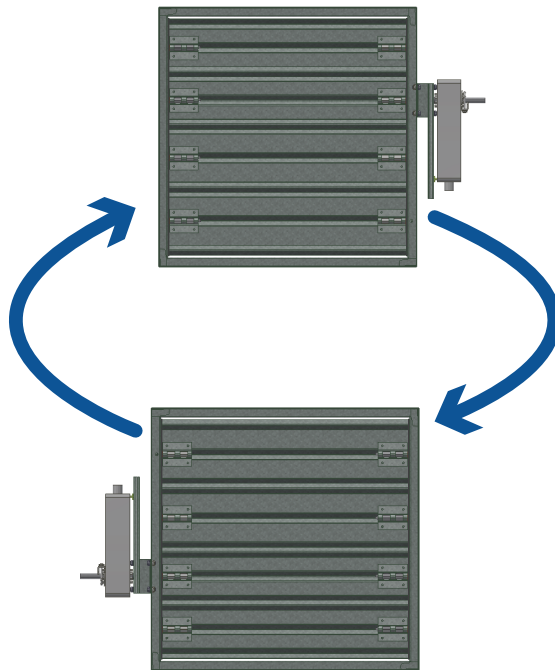

Flip the damper from right hand drive to left hand drive and vice versa.