

## Application

Model DFD-110 is approved for use in walls, floors, and partitions with fire resistance ratings less than 3 hours. This model carries a 1½ hour UL fire damper label. UL 555 classifies dynamic rated fire dampers for use in HVAC systems that are operational in the event of fire.

## Ratings

### UL 555 Fire Resistance

Fire Rating: 1½ hours

### Velocity

4000 fpm (20.3 m/s) vertical mount only, up to 24 in. x 24 in. (610mm x 610mm);  
2000 fpm (10.2 m/s) vertical or horizontal mount all sizes

### Pressure

Maximum: 4 in. wg (1 kPa)

## Construction

Construction	Standard	Optional
Frame Material	Galvanized steel*	-
Frame Depth	2¾ in. (56mm)	-
Blade Material	Galvanized steel*	-
Closure Spring	Stainless steel	-
Fusible Link	165°F (74°C)	212°F or 286°F (100°C or 141°C)
Mounting	Vertical	Horizontal

\* in gauges required by UL listing R13317

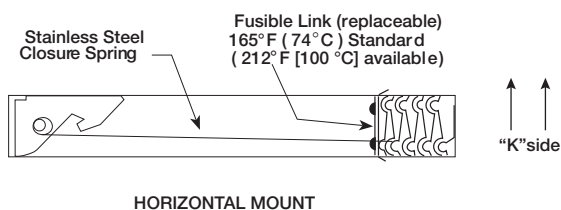

\* W & H dimensions furnished approximately ¼ in. (6mm) undersize.



See complete marking on product.

UL 555 Classification R16690

Model DFD-110 meets the requirements for fire dampers established by:

**National Fire Protection Association**

(NFPA Standards 80, 90A & 101)

**IBC International Building Codes**

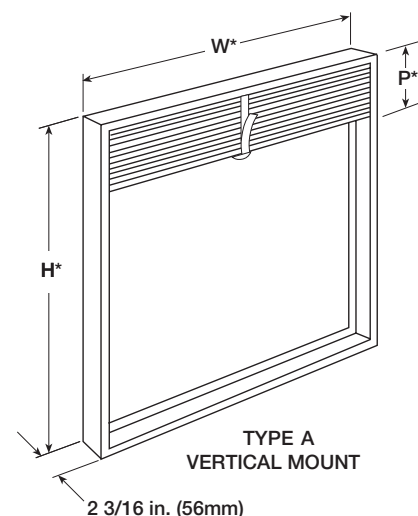

## Options and Accessories

---

- [Breakaway connections](#)
- Clean wrap
- Closed indicator switch
- Flanges
- [Grille tabs](#)
- [Retaining angles](#)
- Sealed transitions and sleeve
- Transitions: B, B2

## Document Links

---



[INSTALLATION](#)



[CATALOG](#)



[WARRANTY](#)



[SELECTION GUIDE](#)

## Factory Sleeve Option

All fire damper installations require the use of sleeves, angles and methods described in the installation instructions. Sleeves can be field fabricated or factory furnished as a completed damper/sleeve assembly.

Sleeves are galvanized steel and are available in 20 through 10 ga. (1mm - 3.5mm) thicknesses and lengths up to 36 in. (914mm).

"K" dimension specifies location of damper within the sleeve. Minimum is 4 in. (102mm), maximum is "L" less 4 in. (102mm), which allows for mounting angle installation, and duct connection at each end of the sleeve. If "K" dimension is not specified, it will be provided as one half of "L" dimension (damper centered in sleeve).

**Note: If using access doors, the door should be installed on the "K" side of the damper.**

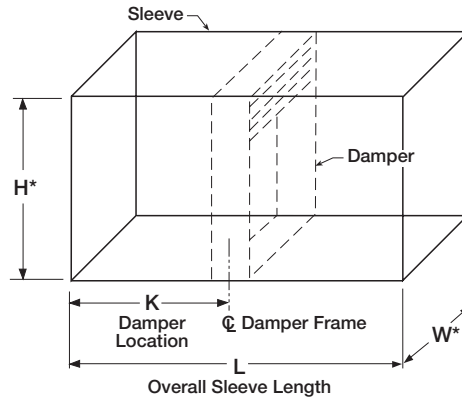

## Sealed Option

When sealed option is selected, B transition will need to be field sealed in the area where duct to sleeve connection is made.

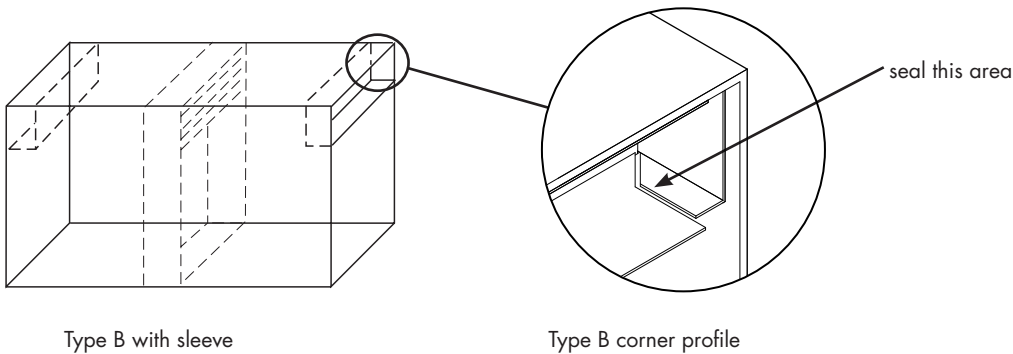

# Type A

Dampers larger than maximum single section size are supplied in 2 or more sections of equal size. Multi-section dampers are factory assembled ready for installation.

## Size Limitations

Inches (mm)	Type A		Type B & B2	
	Minimum	Maximum*	Minimum	Maximum*
<b>Single Section Vertical</b>	4 x 4 (102 x 102)	36 x 36 (914 x 914)	4 x 3 (102 x 76)	36 x 31 (914 x 787)
<b>Multi Section** Vertical</b>	NA	72 x 48 (1829 x 1219)	NA	72 x 45 (1829 x 1143)
<b>Single Section Horizontal</b>	4 x 4 (102 x 102)	30 x 30 (762 x 762)	4 x 3 (102 x 76)	30 x 26 (762 x 660)
<b>Multi Section** Horizontal</b>	NA	48 x 36 (1219 x 914)	NA	48 x 33 (1219 x 838)

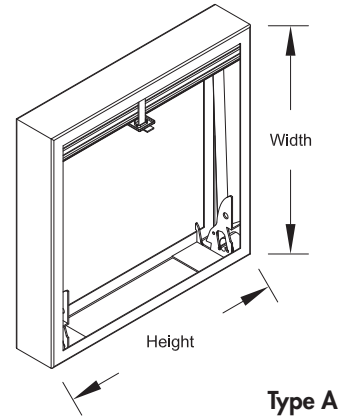

\* Sizes are based on 165°F closure temperature and 2000 fpm. Consult factory for maximum size for different temperatures and velocities.

Max. Type A Dimensions

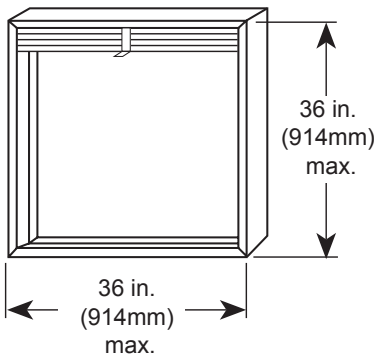

### Multi-Section Limitations

Maximum damper height is 48 in. (1219mm) when combination width is 72 in. (1829mm) or less.

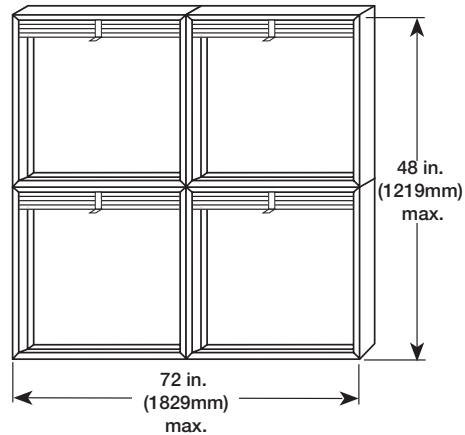

## Types B & B2

Dampers larger than maximum single section size are supplied in 2 or more sections of equal size. Note: All multiple section dampers with transitions, will include a factory installed sleeve.

Max. Type B Dimensions

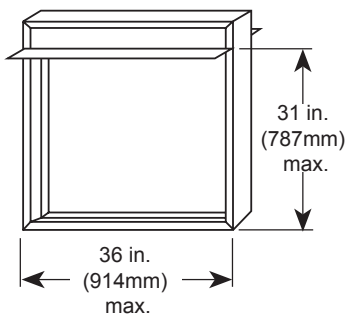

Type B2 side view

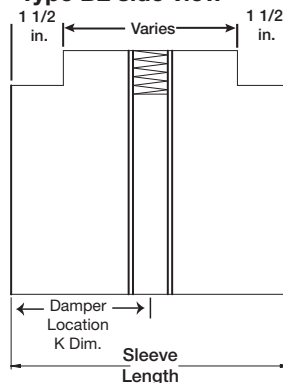

### Multi Section Limitations

Maximum damper height is 45 in. (1143mm) when combination width is 72 in. (1829mm) or less.

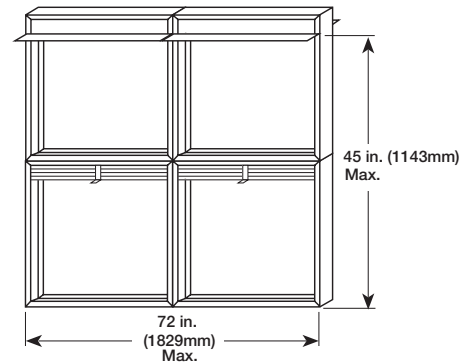

# Types B & B2

## Overall Damper and Blade Stack Dimensions

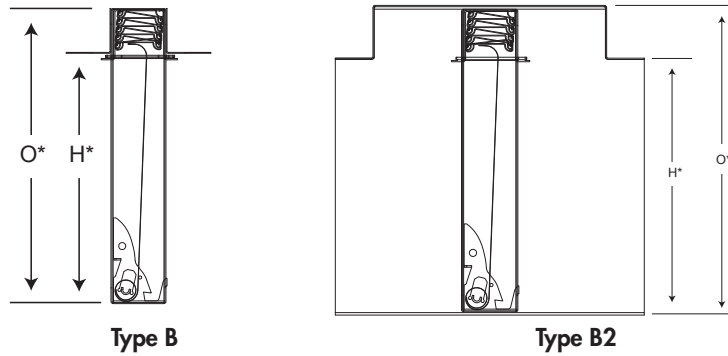

### Vertical Mount

H*	O*	H*	O*
3 (76)	5 (127)	23 (584)	27 (686)
4 (101)	6 (152)	24 (610)	28 (711)
5 (127)	7 (178)	25 (635)	29 (737)
6 (152)	8 (203)	26 (660)	30 (762)
7 (178)	9 (229)	27 (686)	31 (787)
8 (203)	10 (254)	28 (711)	32 (813)
9 (229)	11 (279)	29 (737)	33 (838)
10 (254)	12 (305)	30 (762)	34 (864)
11 (279)	13 (330)	31 (787)	36 (914)
12 (305)	14 (356)	32 (813)	37 (940)
13 (330)	15 (381)	33 (838)	37 (940)
14 (356)	16 (406)	34 (864)	37 (940)
15 (381)	18 (457)	35 (889)	38 (965)
16 (406)	19 (483)	36 (914)	39 (991)
17 (432)	20 (508)	37 (940)	40 (1016)
18 (457)	21 (533)	38 (965)	41 (1041)
19 (483)	22 (559)	39 (991)	42 (1067)
20 (508)	23 (584)	40 (1016)	43 (1092)
21 (533)	24 (610)	41 (1041)	44 (1118)
22 (559)	26 (660)	42 (1067)	45 (1143)

### Horizontal Mount

H*	O*	H*	O*
3 (76)	5 (127)	17 (432)	20 (508)
4 (101)	6 (152)	18 (457)	21 (533)
5 (127)	7 (178)	19 (483)	22 (559)
6 (152)	8 (203)	20 (508)	23 (584)
7 (178)	9 (229)	21 (533)	24 (610)
8 (203)	10 (254)	22 (559)	26 (660)
9 (229)	11 (279)	23 (584)	27 (686)
10 (254)	12 (305)	24 (610)	28 (711)
11 (279)	13 (330)	25 (635)	29 (737)
12 (305)	14 (356)	26 (660)	30 (762)
13 (330)	15 (381)	27 (686)	31 (787)
14 (356)	16 (406)	28 (711)	31 (787)
15 (381)	18 (457)	29 (737)	32 (813)
16 (406)	19 (483)	30 (762)	33 (838)

\* Dimensions in inches (mm). These dimensions are furnished approximately ¼ in. (6mm) undersize. (All 'H' dimensions larger than single section height are two sections high. Refer to chart. The top section is a Type B and the bottom sections are Type A).