

### Application

Model DFD-350 is approved for use in walls, floors, and partitions with fire resistance ratings of 3 hours or more. This model carries a 3 hour UL fire damper label. UL 555 classifies dynamic rated fire dampers for use in HVAC systems that are operational in the event of fire.

### Ratings

#### UL 555 Fire Resistance

Fire Rating: 3 hours

#### Velocity

4000 fpm (20.3 m/s) vertical mount only, up to 24 in. x 24 in. (610mm x 610mm);  
2000 fpm (10.2 m/s) vertical or horizontal mount all sizes

#### Pressure

Maximum: 4 in. wg (1 kPa)

### Construction

	Standard	Optional
<b>Frame Material</b>	Galvanized steel*	-
<b>Frame Depth</b>	3 1/16 in. (94mm)	-
<b>Blade Material</b>	Galvanized steel*	-
<b>Closure Spring</b>	Stainless steel	-
<b>Fusible Link</b>	165°F (74°C)	212°F or 286°F (100°C or 141°C)
<b>Mounting</b>	Vertical	Horizontal

\* in gauges required by UL listing R13317



\* W&H dimension furnished approximately 1/4 in. (6mm) undersize.



See complete marking on product.  
UL 555 Classification R13317

Model DFD-350 meets the requirements for fire damper established by:

**National Fire Protection Association**  
(NFPA Standards 80, 90A, & 101)  
**IBC International Building Codes**

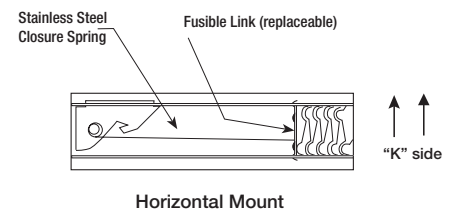
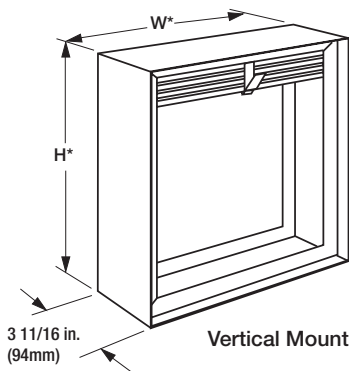

## Options and Accessories

---

- [Breakaway connections](#)
- Clean wrap
- Closed indicator switch
- Flanges
- [Grille tabs](#)
- [Retaining angles](#)
- Sealed transitions and sleeve
- Transitions: B, B2, C, CO, CR, R

## Document Links

---



[INSTALLATION](#)



[CATALOG](#)



[SELECTION GUIDE](#)



[WARRANTY](#)

## Factory Sleeve Option

All fire damper installations require the use of sleeves, angles and methods described in the installation instructions. Sleeves can be field fabricated or factory furnished as a completed damper/sleeve assembly.

Sleeves are galvanized steel and are available in 20 through 10 ga. (1mm - 3.5mm) thicknesses and lengths up to 36 in. (914mm).

"K" dimension specifies location of damper within the sleeve. Minimum is 4 in. (102mm), maximum is "L" less 4 in. (102mm), which allows for mounting angle installation, and duct connection at each end of the sleeve. If "K" dimension is not specified, it will be provided as one half of "L" dimension (damper centered in sleeve).

**Note: If using access doors, the door should be installed on the "K" side of the damper.**

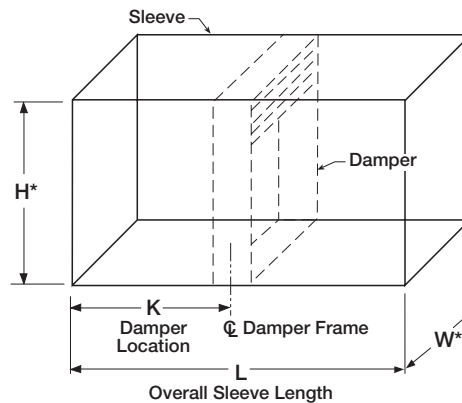

## Sealed Option

When sealed option is selected, B transition will need to be field sealed in the area where duct to sleeve connection is made.

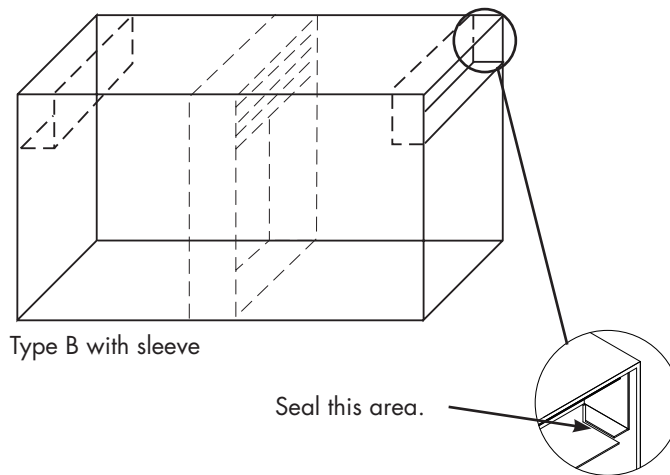

# Type A, B, & B2

Dampers larger than maximum single section sizes are supplied in 2 or more sections of equal size. Multi-section dampers are factory assembled ready for installation.

## Size Limitations

Inches (mm)	Type A		Type B & B2	
	Minimum	Maximum*	Minimum	Maximum*
<b>Single Section Vertical</b>	4 x 4 (102 x 102)	36 x 36 (914 x 914)	4 x 3 (102 x 76)	36 x 31 (914 x 787)
<b>Multi Section** Vertical</b>	NA	48 x 48 (1219 x 1219)	NA	48 x 45 (1219 x 1143)
<b>Single Section Horizontal</b>	4 x 4 (102 x 102)	30 x 30 (762 x 762)	4 x 3 (102 x 76)	30 x 26 (762 x 660)
<b>Multi Section** Horizontal</b>	NA	40 x 36 (1016 x 914)	NA	40 x 33 (1016 x 838)

\* Sizes are based on 165°F closure temperature and 2000 fpm. Consult factory for maximum size for different temperatures and velocities.

\*\* Consult factory for number of sections.

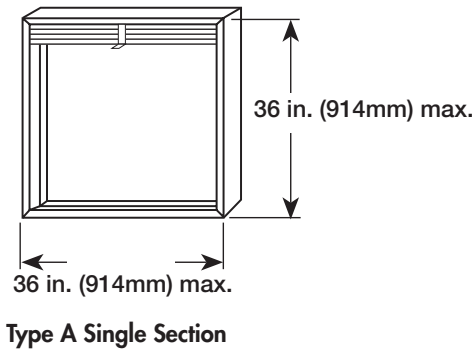
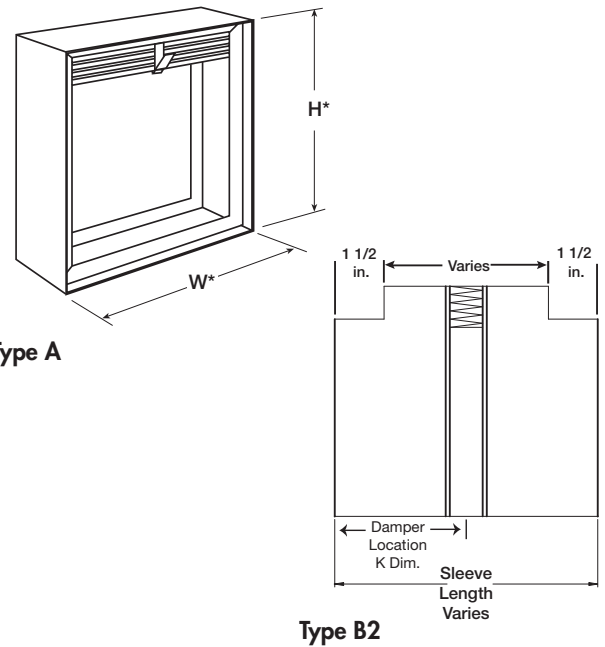

### Multi-Section Limitations

Maximum damper height is 48 in. (1219mm) when combination width is 48 in. (1219mm) or less.

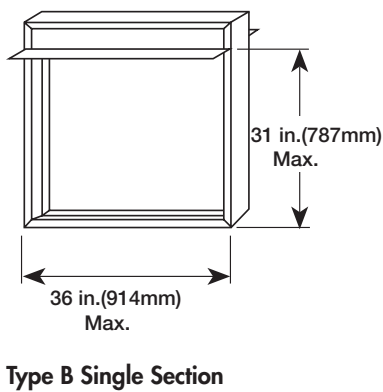
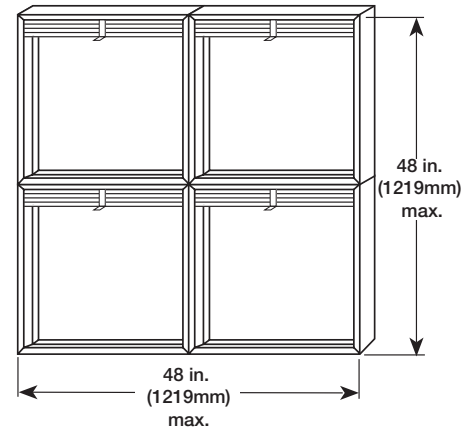

### Multi Section Limitations

Maximum damper height is 45 in. (1143mm) when combination width is 48 in. (1219mm) or less.

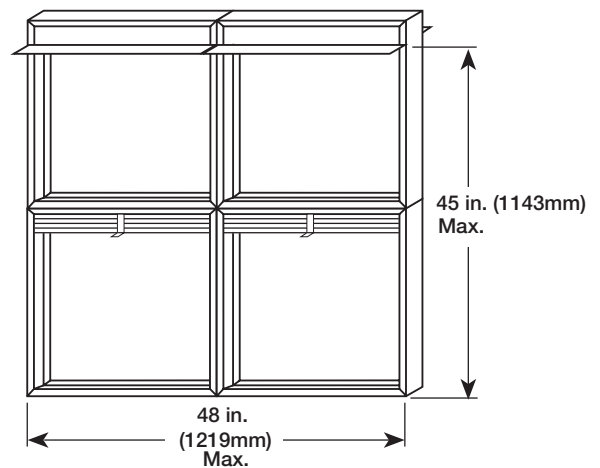

## Type A, B, & B2....

### Vertical Mount

H*	O*	H*	O*
3 (76)	5 (127)	25 (635)	29 (737)
4 (102)	6 (152)	26 (660)	30 (762)
5 (127)	7 (178)	27 (686)	31 (787)
6 (152)	8 (203)	28 (711)	32 (813)
7 (178)	9 (229)	29 (737)	33 (838)
8 (203)	10 (254)	30 (762)	34 (864)
9 (229)	11 (279)	31 (787)	36 (914)
10 (254)	12 (305)	32 (813)	37 (940)
11 (279)	13 (330)	33 (838)	37 (940)
12 (305)	14 (356)	34 (864)	37 (940)
13 (330)	15 (381)	35 (889)	38 (965)
14 (356)	16 (406)	36 (914)	39 (991)
15 (381)	18 (457)	37 (940)	40 (1016)
16 (406)	19 (483)	38 (965)	41 (1041)
17 (432)	20 (508)	39 (991)	42 (1067)
18 (457)	21 (533)	40 (1016)	43 (1092)
19 (483)	22 (559)	41 (1041)	44 (1118)
20 (508)	23 (584)	42 (1067)	45 (1143)
21 (533)	24 (610)	43 (1092)	46 (1168)
22 (559)	26 (660)	44 (1118)	47 (1194)
23 (584)	27 (686)	45 (1143)	48 (1219)
24 (610)	28 (711)		

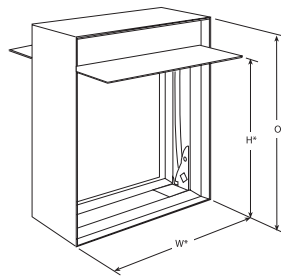

Type B

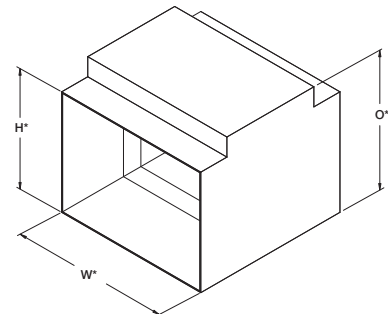

Type B2

### Horizontal Mount

H*	O*	H*	O*
3 (76)	5 (127)	19 (483)	22 (559)
4 (102)	6 (152)	20 (508)	23 (584)
5 (127)	7 (178)	21 (533)	24 (610)
6 (152)	8 (203)	22 (559)	26 (660)
7 (178)	9 (229)	23 (584)	27 (686)
8 (203)	10 (254)	24 (610)	28 (711)
9 (229)	11 (279)	25 (635)	29 (737)
10 (254)	12 (305)	26 (660)	30 (762)
11 (279)	13 (330)	27 (686)	31 (787)
12 (305)	14 (356)	28 (711)	31 (787)
13 (330)	15 (381)	29 (737)	32 (813)
14 (356)	16 (406)	30 (762)	33 (838)
15 (381)	18 (457)	31 (787)	34 (864)
16 (406)	19 (483)	32 (813)	35 (889)
17 (432)	20 (508)	33 (838)	36 (914)
18 (457)	21 (533)		

\* Dimension is inches (mm). These dimensions are furnished approximately 1/4 in. (6mm) undersize. All 'H' dimensions larger than single section height are two sections high. Refer to size limitations chart. The top section is a Type B/B2 and the bottom section are Type A.

## Type C, CO, CR, & R

Dampers larger than maximum single section sizes are supplied in 2 or more sections of equal size. Note: All multiple section dampers with transitions, will include a factory installed sleeve.

Inches (mm)	Type CR		Type CO & C		Type R+	
	Minimum	Maximum*	Minimum	Maximum*	Minimum	Maximum*
<b>Single section Vertical</b>	3 (76)	30 (762)	3 x 3 (76 x 76)	34 x 30 (864 x 762)	3 (76)	34 (864)
<b>Multi Section** Vertical</b>	NA	44 (1118)	NA	46 x 44 (1168 x 1118)	NA	46 (1168)
<b>Single Section Horizontal</b>	3 (76)	25 (635)	3 x 3 (76 x 76)	28 x 25 (711 x 635)	3 (76)	28 (711)
<b>Multi Section** Horizontal</b>	NA	32 (813)	NA	38 x 32 (965 x 813)	NA	34 (864)

+ With 2 in. (51mm) offset. Sizes adjust with 1 in. (25mm) offset.

\* Sizes are based on 165°F closure temperature and 2000 fpm. Consult factory for maximum size for different temperatures and velocities.

\*\* Consult factory for number of sections.

# Type C, CO, CR & R....

## Maximum Single Section Dimensions

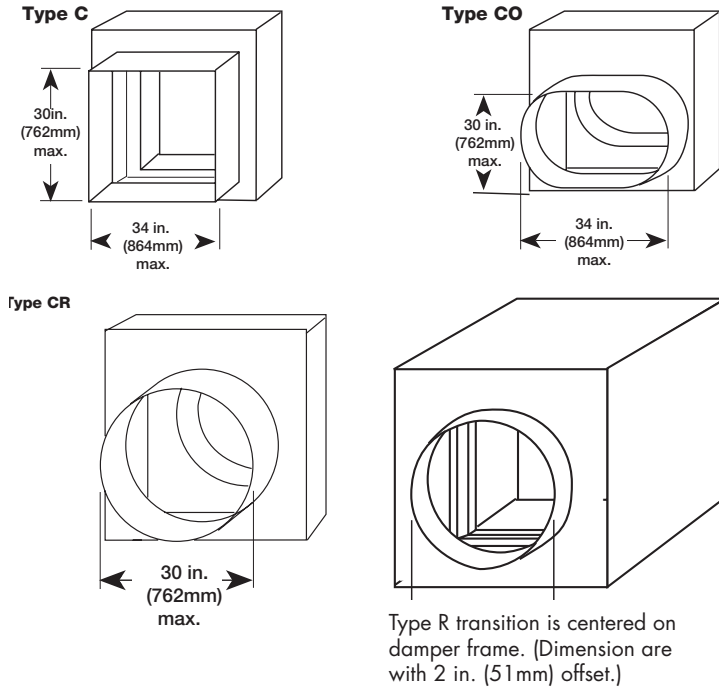

C, CO, CR transitions are positioned 1 in. (25mm) from bottom of sleeve.

## Overall Damper Dimensions

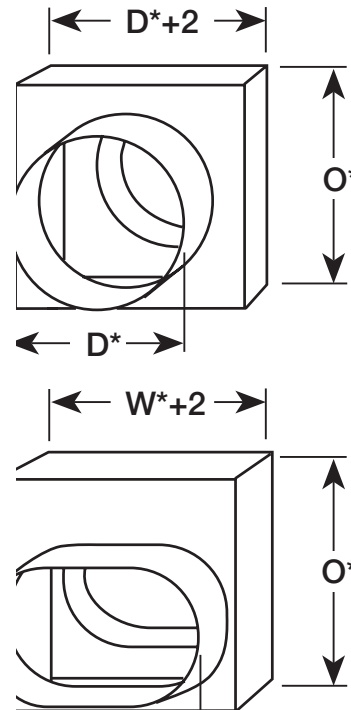

### Vertical Mount

H* or D*	O*	H* or D*	O*	H* or D*	O*
3 (76)	6 (152)	17 (432)	21 (533)	31 (787)	37 (940)
4 (102)	7 (178)	18 (457)	22 (559)	32 (813)	37 (940)
5 (127)	8 (203)	19 (483)	23 (584)	33 (838)	39 (991)
6 (152)	9 (229)	20 (508)	24 (610)	34 (864)	40 (1016)
7 (178)	10 (254)	21 (533)	26 (660)	35 (889)	41 (1041)
8 (203)	11 (279)	22 (559)	27 (686)	36 (914)	42 (1067)
9 (229)	12 (305)	23 (584)	28 (711)	37 (940)	43 (1092)
10 (254)	13 (330)	24 (610)	29 (737)	38 (965)	44 (1118)
11 (279)	14 (356)	25 (635)	30 (762)	39 (991)	45 (1143)
12 (305)	15 (381)	26 (660)	31 (787)	40 (1016)	46 (1168)
13 (330)	16 (406)	27 (686)	32 (813)	41 (1041)	47 (1194)
14 (356)	18 (457)	28 (711)	33 (838)	42 (1067)	48 (1219)
15 (381)	19 (483)	29 (737)	34 (864)	43 (1092)	49 (1244)
16 (406)	20 (508)	30 (762)	36 (914)	44 (1118)	50 (1270)

### Horizontal Mount

H* or D*	O*	H* or D*	O*
3 (76)	6 (152)	18 (457)	22 (559)
4 (102)	7 (178)	19 (483)	23 (584)
5 (127)	8 (203)	20 (508)	24 (610)
6 (152)	9 (229)	21 (533)	26 (660)
7 (178)	10 (254)	22 (559)	27 (686)
8 (203)	11 (279)	23 (584)	28 (711)
9 (229)	12 (305)	24 (610)	29 (737)
10 (254)	13 (330)	25 (635)	30 (762)
11 (279)	14 (356)	26 (660)	31 (787)
12 (305)	15 (381)	27 (686)	31 (787)
13 (330)	16 (406)	28 (711)	32 (813)
14 (356)	18 (457)	29 (737)	33 (838)
15 (381)	19 (483)	30 (762)	34 (864)
16 (406)	20 (508)	31 (787)	35 (889)
17 (432)	21 (533)	32 (813)	36 (914)

\* Dimension is inches (mm). These dimensions are furnished approximately 1/4 in. (6mm) undersize. All 'H' dimensions larger than single section height are two sections high. Refer to size limitations chart.