

Application

Model FD-150 is a static rated fire damper approved for use in floors, walls, and partitions with fire resistance ratings less than 3 hours. This model carries a 1 1/2 hour UL fire damper label. UL 555 classifies static rated fire dampers for use in HVAC systems that are automatically shut down in the event of fire.

Ratings

UL 555 Fire Resistance Rating

Fire Rating: 1 1/2 hours

Construction

	Standard	Optional
Frame Material	Galvanized steel*	-
Frame Depth	3 11/16 in. (94mm)	-
Blade Material	Galvanized steel*	-
Closure Spring	Stainless steel	-
Fusible Link	165°F (74°C)	212°F (100°C)
Mounting	Vertical	Horizontal

* in gauges required by UL listing R16690



* These dimensions are furnished approximately 1/4 in. (6mm) undersize.



See complete marking on product.
UL 555 Classification R13317

Model FD-150 meets the requirements for fire dampers established by:

National Fire Protection Association

NFPA Standards 80, 90, & 101

International Building Code (IBC)

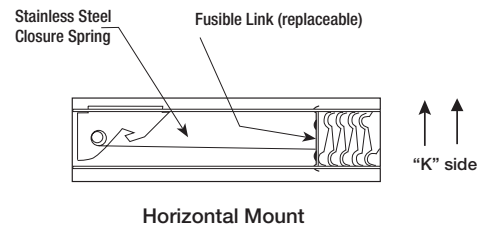
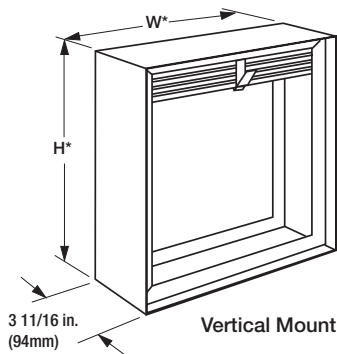

Options and Accessories

- Breakaway connections
- Clean wrap
- Closed indicator switch
- Flanges
- Grille tabs
- Retaining angles
- Sealed transitions and sleeve
- Transitions: B, B2, C, CO, CR, and R

Document Links



[INSTALLATION](#)



[CATALOG](#)



[SELECTION GUIDE](#)



[WARRANTY](#)

Factory Sleeve Option FD-150

All fire damper installations require the use of sleeves, angles and methods described in the installation instructions. Sleeves can be field fabricated or factory furnished as a completed damper/sleeve assembly.

Sleeves are galvanized steel and are available in 20 through 10 ga. (1mm - 3.5mm) thicknesses and lengths up to 36 in. (914mm).

"K" dimension specifies location of damper within the sleeve. Minimum is 4 in. (102mm), maximum is "L" less 4 in. (102mm), which allows for mounting angle installation, and duct connection at each end of the sleeve. If "K" dimension is not specified, it will be provided as one half of "L" dimension (damper centered in sleeve).

Note: If using access doors, the door should be installed on the "K" side of the damper.

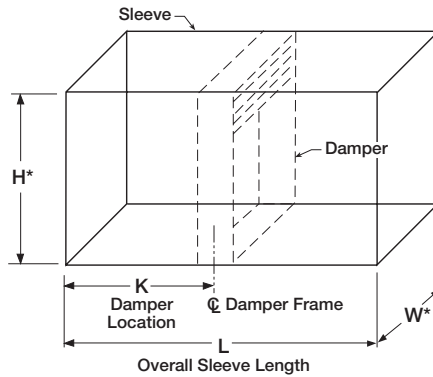

Sealed Option

When sealed option is selected, B transition will need to be field sealed in the area where duct to sleeve connection is made.

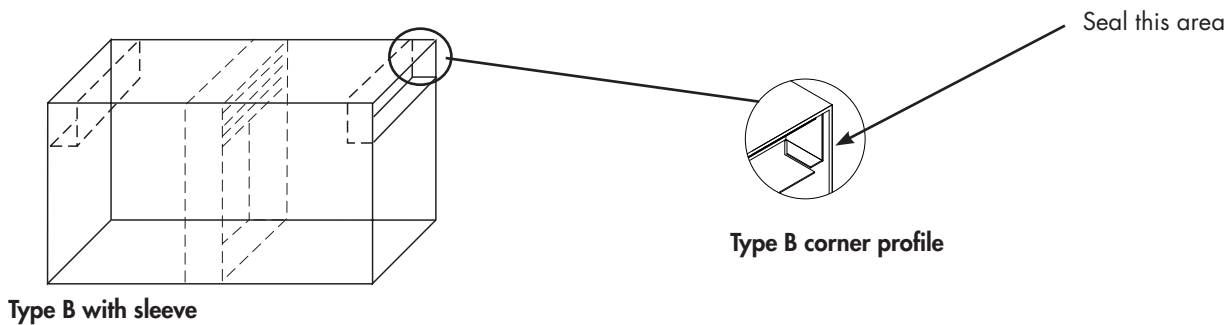

Type A

Dampers larger than maximum single section size are supplied in two or more sections of equal size. Multi-section dampers are factory assembled ready for installation.

Size Limitations

Inches (mm)	Type A		Type B & B2	
	Minimum	Maximum	Minimum	Maximum
Single Section Vertical	4 x 4 (102 x 102)	48 x 48 (1219 x 1219)	4 x 3 (102 x 76)	48 x 42 (1219 x 1067)
Multi Section Vertical*	NA	96 x 48, 74 x 74 or 120 x 40 (2438 x 1219, 1880 x 1880 or 3048 x 1016)	NA	96 x 42, 74 x 69 or 120 x 35 (2438 x 1067, 1880 x 1753 or 2048 x 889)
Single Section Horizontal	4 x 4 (102 x 102)	48 x 48 (1219 x 1219)	4 x 3 (102 x 76)	48 x 36 (1219 x 914)
Multi Section Horizontal*	NA	96 x 48 or 120 x 40 (2438 x 1219 or 3048 x 1016)	NA	96 x 42 or 120 x 35 (2438 x 1067 or 3048 x 889)

*Consult factory for number of sections.

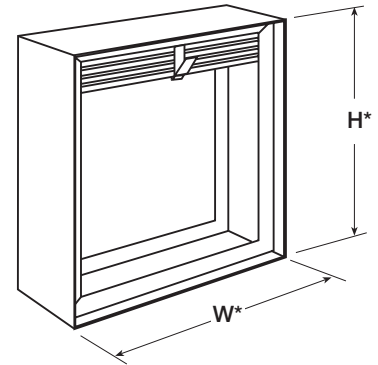

* These dimension are furnished approximately ¼ in. (6mm) undersize.

① Maximum Single Section Dimensions

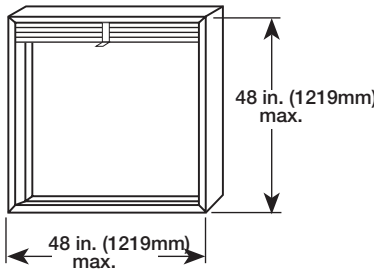

② Multi-Section Limitations

Maximum height is 48 in. (1219mm) when width is 96 in. (2438mm) or less.

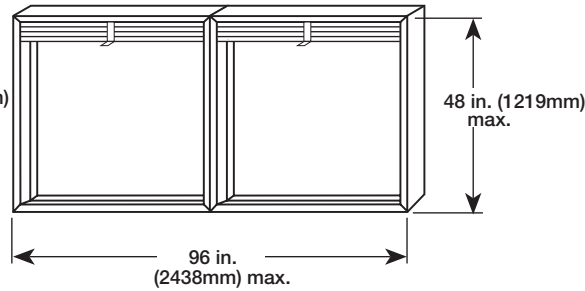

③ Multi-Section Limitations

Maximum height is 74 in. (1880mm) when width is less than or equal to 74 in. (1880mm). (Vertical mullion provided on dampers over 37 in. (940mm) wide and 48 in. (1219mm) high.

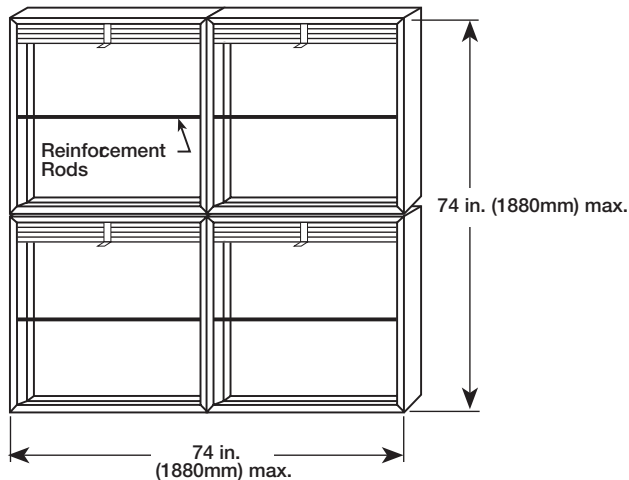

Type B & B2

Dampers larger than maximum single section size are supplied in two or more sections of equal size. Multi-section dampers are factory assembled ready for installation.

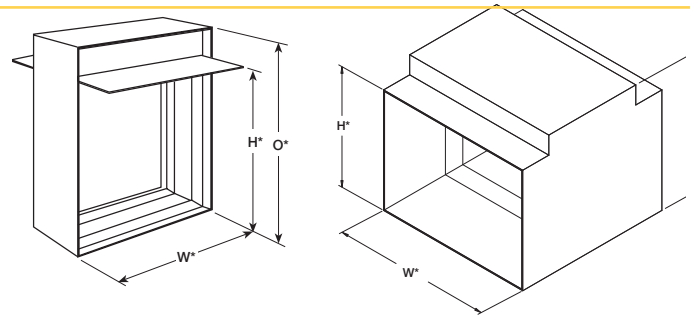

① Maximum Single Section Dimensions

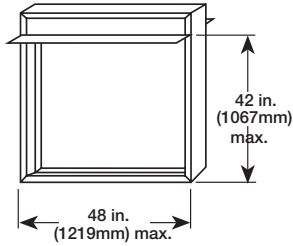

② Multi-Section Limitations

Maximum height is 42 in. (1067mm) when width is 96 in. (2438mm) or less

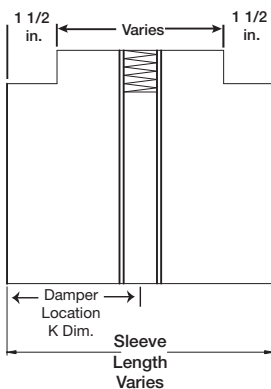
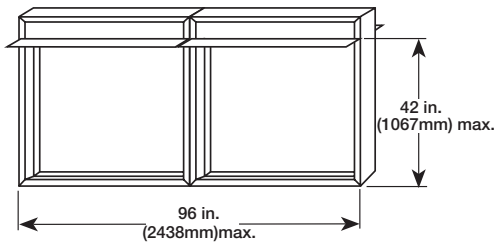

Type B2 side view

Type B

H*	O*
3 (76)	5 (127)
4 (102)	6 (152)
5 (127)	7 (178)
6 (152)	8 (203)
7 (178)	9 (229)
8 (203)	10 (254)
9 (229)	11 (279)
10 (254)	12 (305)
11 (279)	13 (330)
12 (305)	14 (356)
13 (330)	15 (381)
14 (356)	16 (406)
15 (381)	18 (457)
16 (406)	19 (483)
17 (432)	20 (508)
18 (457)	21 (533)
19 (483)	22 (559)
20 (508)	23 (584)
21 (533)	24 (610)
22 (559)	26 (660)
23 (584)	27 (686)
24 (610)	28 (711)
25 (635)	29 (737)
26 (660)	30 (762)
27 (686)	31 (787)
28 (711)	32 (813)
29 (737)	33 (838)
30 (762)	34 (864)
31 (787)	36 (914)
32 (813)	37 (940)
33 (838)	38 (965)
34 (864)	39 (991)
35 (889)	40 (1016)

Type B2

H*	O*
36 (914)	41 (1041)
37 (940)	42 (1067)
38 (965)	44 (1118)
39 (991)	45 (1143)
40 (1016)	46 (1168)
41 (1041)	47 (1194)
42 (1067)	48 (1219)
43 (1092)	49 (1245)
44 (1118)	49 (1245)
45 (1143)	49 (1245)
46 (1168)	50 (1270)
47 (1194)	51 (1295)
48 (1219)	52 (1321)
49 (1245)	53 (1346)
50 (1270)	54 (1372)
51 (1295)	55 (1397)
52 (1321)	56 (1422)
53 (1346)	57 (1448)
54 (1372)	58 (1473)
55 (1397)	59 (1499)
56 (1422)	60 (1524)
57 (1448)	61 (1549)
58 (1473)	62 (1575)
59 (1499)	63 (1600)
60 (1524)	64 (1626)
61 (1549)	65 (1651)
62 (1575)	66 (1676)
63 (1600)	67 (1702)
64 (1626)	68 (1727)
65 (1651)	70 (1778)
66 (1676)	71 (1803)
67 (1702)	72 (1829)
68 (1727)	73 (1854)
69 (1753)	74 (1880)

All multiple section dampers with B or B2 transitions, will include a factory installed sleeve.

* Dimension in inches (mm). These dimensions are furnished 1/4 in. (6mm) undersize. (All 'H' dimensions larger than 43 in. (1092mm) are two sections high. The bottom section is a Type A and the top section is a Type B & B2.)

FD-150 Type CR, CO, C & R

Dampers larger than maximum single section size are supplied in two or more sections of equal size. Multi-section dampers are factory assembled ready for installation.

Inches (mm)	Type CR		Type CO & C		Type R ^{*1}	
	Minimum	Maximum	Minimum	Maximum	Minimum	Maximum
Single section Vertical	3 (76)	41 (1041)	3 x 3 (76 x 76)	46 x 41 (1168 x 1041)	3 (76)	46 (1168)
Multi Section Vertical**	NA	68 (1727)	NA	94 x 41, 72 x 68 or 118 x 34 (2388 x 1041, 1829 x 1727 or 2997 x 864)	NA	72 (1829)
Single Section Horizontal	3 (76)	41 (1041)	3 x 3 (76 x 76)	46 x 41 (1168 x 1041)	3 (76)	46 (1168)
Multi Section Horizontal**	NA	NA	NA	94 x 41 or 118 x 34 (2388 x 1041 or 2997 x 864)	NA	NA

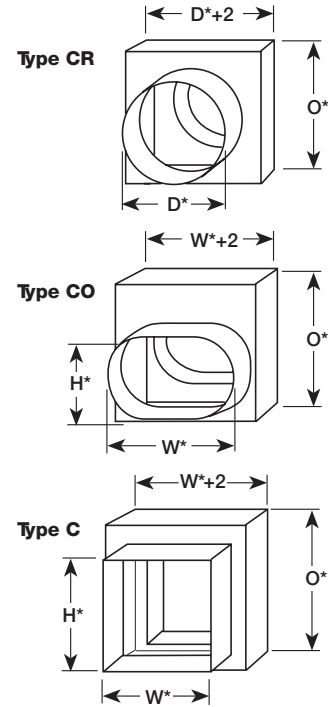

*¹ With 2 in. (51mm) offset. Sizes adjust with an 1 in (25mm) offset.

** Consult factory for number of sections.

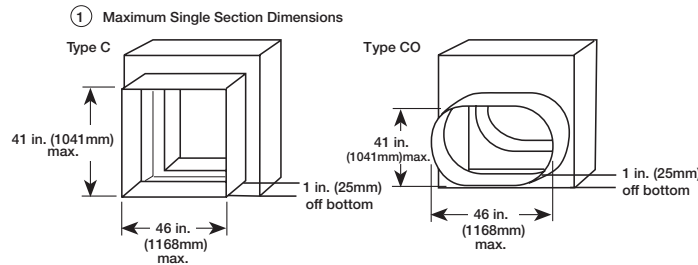

C, CO, CR transitions are positioned 1 in. (25mm) from bottom of sleeve.

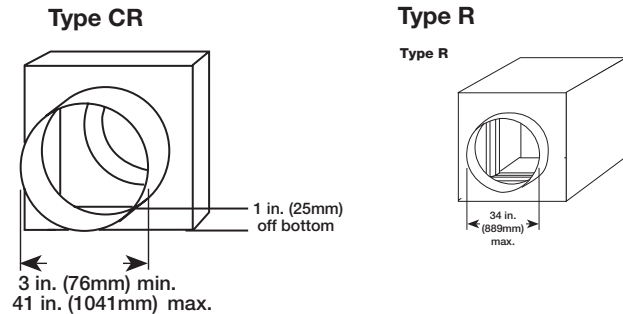

H* or D*	O*	H* or D*	O*	H* or D*	O*
3 (76)	6 (152)	25 (635)	30 (762)	47 (1194)	52 (1321)
4 (102)	7 (178)	26 (660)	31 (787)	48 (1219)	53 (1346)
5 (127)	8 (203)	27 (686)	32 (813)	49 (1245)	54 (1372)
6 (152)	9 (229)	28 (711)	33 (838)	50 (1270)	55 (1397)
7 (178)	10 (254)	29 (737)	34 (864)	51 (1295)	56 (1422)
8 (203)	11 (279)	30 (762)	36 (914)	52 (1321)	57 (1448)
9 (229)	12 (305)	31 (787)	37 (940)	53 (1346)	58 (1473)
10 (254)	13 (330)	32 (813)	38 (965)	54 (1372)	59 (1499)
11 (279)	14 (356)	33 (838)	39 (991)	55 (1397)	60 (1524)
12 (305)	15 (381)	34 (864)	40 (1016)	56 (1422)	61 (1549)
13 (330)	16 (406)	35 (889)	41 (1041)	57 (1448)	62 (1575)
14 (356)	18 (457)	36 (914)	42 (1067)	58 (1473)	63 (1600)
15 (381)	19 (483)	37 (940)	44 (1118)	59 (1499)	64 (1626)
16 (406)	20 (508)	38 (965)	45 (1143)	60 (1524)	65 (1651)
17 (432)	21 (533)	39 (991)	46 (1168)	61 (1549)	66 (1676)
18 (457)	22 (559)	40 (1016)	47 (1194)	62 (1575)	67 (1702)
19 (483)	23 (584)	41 (1041)	48 (1219)	63 (1600)	68 (1727)
20 (508)	24 (610)	42 (1067)	49 (1245)	64 (1626)	70 (1778)
21 (533)	26 (660)	43 (1092)	49 (1245)	65 (1651)	71 (1803)
22 (559)	27 (686)	44 (1118)	49 (1245)	66 (1676)	72 (1829)
23 (584)	28 (711)	45 (1143)	50 (1270)	67 (1702)	73 (1854)
24 (610)	29 (737)	46 (1168)	51 (1295)	68 (1727)	74 (1880)

* Dimension in inches (mm). These dimensions are furnished 1/4 in. (6mm) undersize except round and oval dimensions are approximately 1/8 in. (3mm) undersize. (All 'H' dimensions larger than single section height are two sections high.)



Copyright © 2024 Venco Products

FD-150, R8, January 2024

Venco Products reserves the right to make product changes without notice.