

Application

Model FD-350 is a static rated fire damper approved for use in walls, floors, and partitions with fire resistance ratings of 3 hours or more. This model carries a 3 hour UL fire damper label. UL555 classifies static rated fire dampers for use in HVAC systems that are automatically shut down in the event of fire.

Ratings

UL 555 Fire Resistance Rating

Fire Rating: 3 Hour

Construction

	Standard	Optional
Frame Material	Galvanized steel*	-
Frame Depth	3 ¹¹ / ₁₆ in. (94mm)	-
Blade Material	Galvanized steel*	-
Closure Spring	Stainless steel	-
Fusible Link	165°F (74°C)	212°F (100°C)
Mounting	Vertical	Horizontal

* in gauges required by UL listing R16690



* These dimensions are furnished approximately 1/4 in. (6mm) undersize.



See complete marking on product.
UL 555 Classification R16690

Model FD-350 meets the requirements for fire damper established by:
National Fire Protection Association
 (NFPA Standards 80, 90A & 101)
Underwriters Laboratories Standard 555
 (Listing #R16690)
IBC International Building Codes

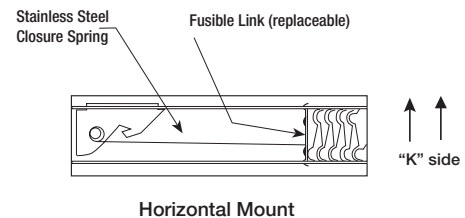
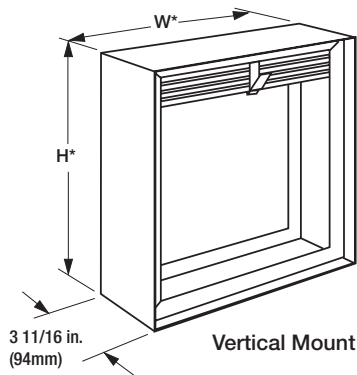

Options and Accessories

- Breakaway connections
- Clean wrap
- Closed indicator switch
- Flanges
- Grille tabs
- Retaining angles
- Security bars
- Sealed transitions and sleeve
- Transitions: B, B2, C, CO, CR, and R

Document Links



[INSTALLATION](#)



[CATALOG](#)



[WARRANTY](#)



[SELECTION GUIDE](#)

Factory Sleeve Option

All fire damper installations require the use of sleeves, angles and methods described in the installation instructions. Sleeves can be field fabricated or factory furnished as a completed damper/sleeve assembly.

Sleeves are galvanized steel and are available in 20 through 10 ga. (1mm - 3.5mm) thicknesses and lengths up to 36 in. (914mm).

"K" dimension specifies location of damper within the sleeve. Minimum is 4 in. (102mm), maximum is "L" less 4 in. (102mm), which allows for mounting angle installation, and duct connection at each end of the sleeve. If "K" dimension is not specified, it will be provided as one half of "L" dimension (damper centered in sleeve).

Note: If using access doors, the door should be installed on the "K" side of the damper.

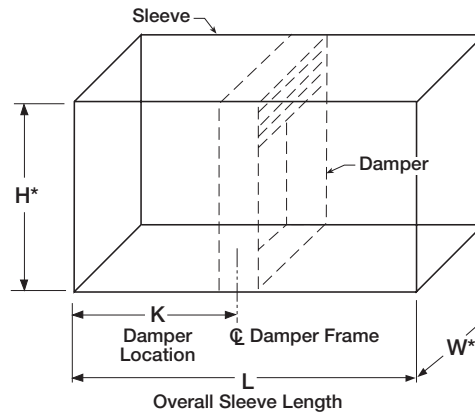

Sealed Option

When sealed option is selected, B transition will need to be field sealed in the area where duct to sleeve connection is made.

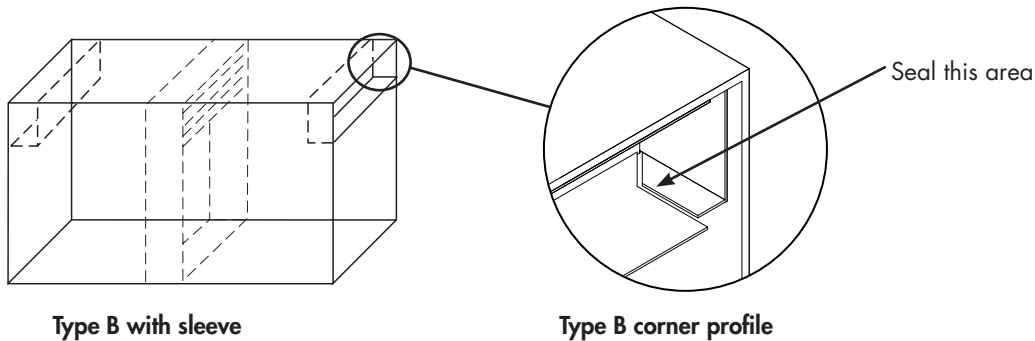

Type A

Dampers larger than maximum single section size are supplied in 2 or more sections of equal size. Multi-section dampers are factory assembled ready for installation.

Size Limitations

Inches (mm)	Type A		Type B & B2	
	Minimum	Maximum	Minimum	Maximum
Single Section Vertical	4 x 4 (102 x 102)	48 x 48 (1219 x 1219)	4 x 3 (102 x 76)	48 x 42 (1219 x 1067)
Single Section Horizontal	4 x 4 (102 x 102)	40 x 40 (1016 x 1016)	4 x 3 (102 x 76)	40 x 35 (1016 x 889)
Multi Section Horizontal**	NA	80 X 40 (2032 X 1016)	NA	80 X 35 (2032 X 889)

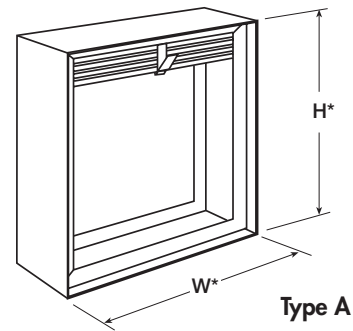

* These dimensions are furnished approximately 1/4 in. (6mm) undersize.

** Consult factory for number of sections.

Maximum Single Section Dimensions

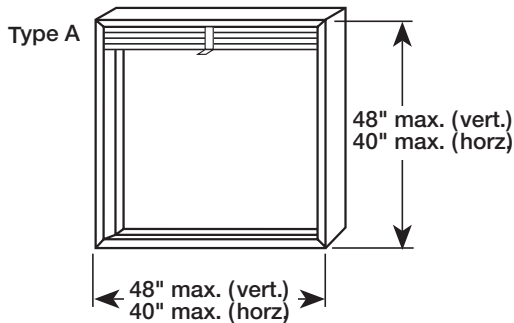

Multi-Section Limitations (horizontal only)

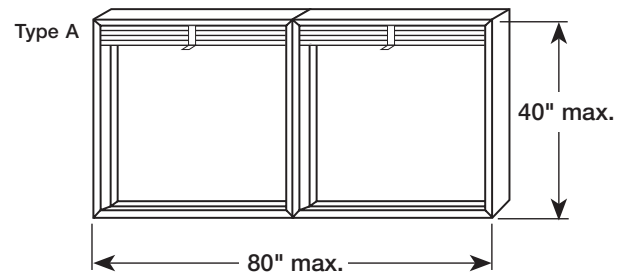

Type B & B2

Dampers larger than maximum single section size are supplied in 2 or more sections of equal size.

Note: All multiple section dampers with transitions, will include a factory installed sleeve.

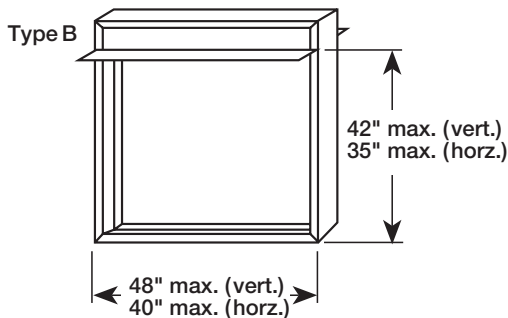

Type B2

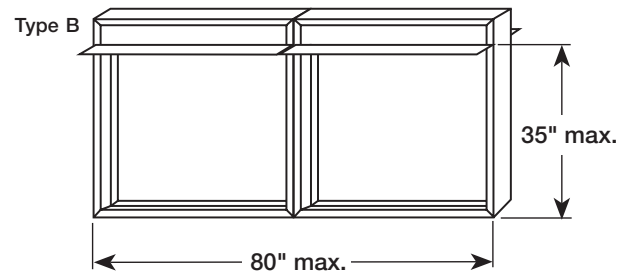
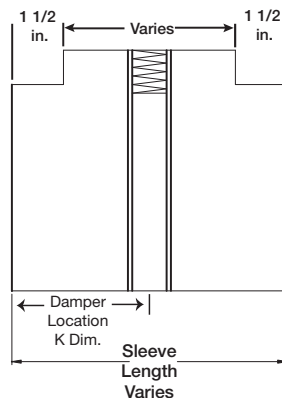

Type B & B2 cont...

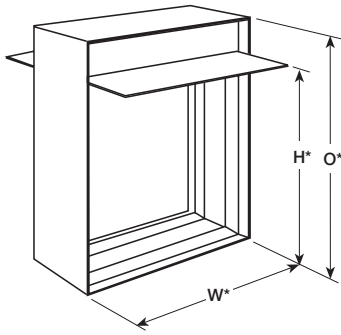

Type B

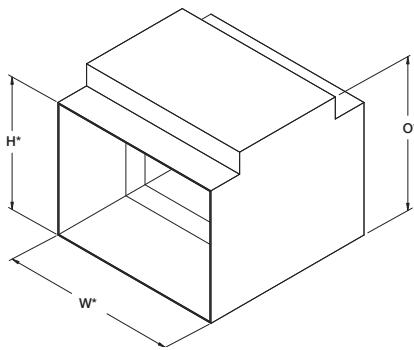

Type B2

Type B & B2 Overall Damper Dimensions

H*	O*	H*	O*
3 (76)	5 (127)	23 (584)	27 (686)
4 (102)	6 (152)	24 (610)	28 (711)
5 (127)	7 (178)	25 (635)	29 (737)
6 (152)	8 (203)	26 (660)	30 (762)
7 (178)	9 (229)	27 (686)	31 (787)
8 (203)	10 (254)	28 (711)	32 (813)
9 (229)	11 (279)	29 (737)	33 (838)
10 (254)	12 (305)	30 (762)	34 (864)
11 (279)	13 (330)	31 (787)	36 (914)
12 (305)	14 (356)	32 (813)	37 (940)
13 (330)	15 (381)	33 (838)	38 (965)
14 (356)	16 (406)	34 (864)	39 (991)
15 (381)	18 (457)	35 (889)	40 (1016)
16 (406)	19 (483)	36 (914)	41 (1041)
17 (432)	20 (508)	37 (940)	42 (1067)
18 (457)	21 (533)	38 (965)	44 (1118)
19 (483)	22 (559)	39 (991)	45 (1143)
20 (508)	23 (584)	40 (1016)	46 (1168)
21 (533)	24 (610)	41 (1041)	47 (1194)
22 (559)	26 (660)	42 (1067)	48 (1219)

Type C, CO, CR, & R

Dampers larger than maximum single section size are supplied in 2 or more sections of equal size. **Note:** All multiple section dampers with transitions, will include a factory installed sleeve.

Inches (mm)	Type CR		Type C & CO		Type R*1	
	Minimum	Maximum	Minimum	Maximum	Minimum	Maximum
Single Section Vertical	3 (76)	41 (1041)	3 x 3 (76 x 76)	46 x 41 (1168 x 1041)	3 (76)	46 (1219)
Single Section Horizontal	3 (76)	34 (864)	3 x 3 (76 x 76)	38 x 34 (965 x 864)	3 (76)	38 (1016)
Multi-Section Horizontal**	NA	NA	NA)	78 X 34 (1981 X 864)	NA	NA

** Consult factory for number of sections.

*1 With 2 in. (51mm) offset. Sizes adjust with an 1 in. (25mm) offset.

Type C, CO, CR, and R....

Maximum Single Section Dimen:

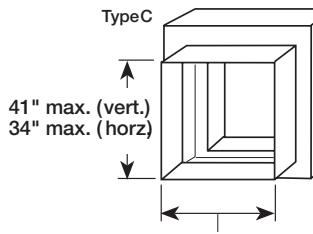

Dimensions

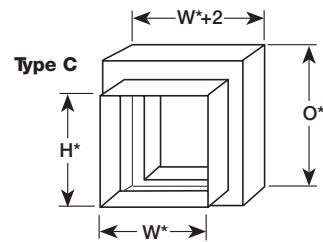
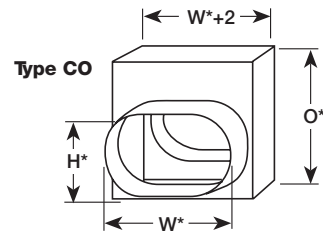
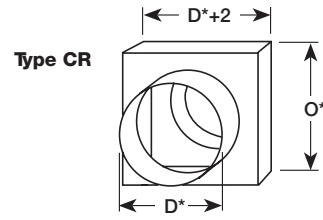
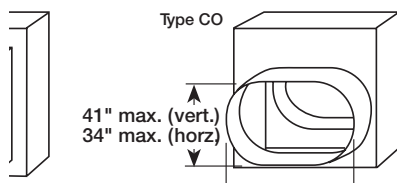

C, CO, CR transitions are positioned 1 in. (25mm) from bottom of sleeve

Type CR

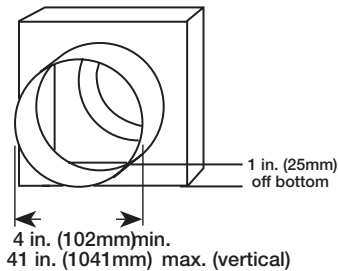

Type R

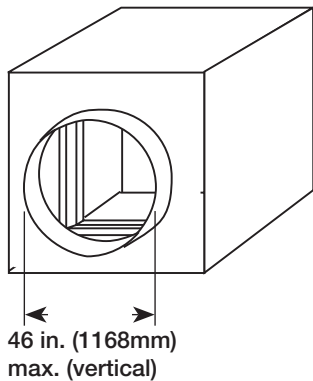

* All multiples section dampers, with transitions, will include a factory installed sleeve.

H* or D*	O*	H* or D*	O*
3 (76)	6 (152)	23 (584)	28 (711)
4 (102)	7 (178)	24 (610)	29 (737)
5 (127)	8 (203)	25 (635)	30 (762)
6 (152)	9 (229)	26 (660)	31 (787)
7 (178)	10 (254)	27 (686)	32 (813)
8 (203)	11 (279)	28 (711)	33 (838)
9 (229)	12 (305)	29 (737)	34 (864)
10 (254)	13 (330)	30 (762)	36 (914)
11 (279)	14 (356)	31 (787)	37 (940)
12 (305)	15 (381)	32 (813)	38 (965)
13 (330)	16 (406)	33 (838)	39 (991)
14 (356)	18 (457)	34 (864)	40 (1016)
15 (381)	19 (483)	35 (889)	41 (1041)
16 (406)	20 (508)	36 (914)	42 (1067)
17 (432)	21 (533)	37 (940)	44 (1118)
18 (457)	22 (559)	38 (965)	45 (1143)
19 (483)	23 (584)	39 (991)	46 (1168)
20 (508)	24 (610)	40 (1016)	47 (1194)
21 (533)	26 (660)	41 (1041)	48 (1219)
22 (559)	27 (686)		

* Dimensions are inches (mm). These dimensions are furnished approximately 1/4 in. (6mm) undersize, except round and oval dimensions (D, H, W) are approximately 1/8 in. (3mm) undersize. (All 'H' dimensions larger than single section height are two sections high. Refer to chart.)



Copyright © 2024 Venco Products

FD-350, R5, January 2024

Venco Products reserves the right to make product changes without notice.