

## Application

Model FD-350 is a static rated fire damper approved for use in walls, floors, and partitions with fire resistance ratings of 3 hours or more. This model carries a 3 hour UL 555 fire damper label and is static rated fire for use in HVAC systems that are automatically shut down in the event of fire.

## Ratings

### UL 555 Fire Resistance Rating

Fire Rating: 3 Hour

## Construction

	Standard	Optional
<b>Frame Material</b>	Galvanized steel*	-
<b>Frame Depth</b>	3 <sup>11</sup> / <sub>16</sub> in. (94mm)	-
<b>Blade Material</b>	Galvanized steel*	-
<b>Closure Spring</b>	Stainless steel	-
<b>Fusible Link</b>	165°F (74°C)	212°F (100°C)
<b>Mounting</b>	Vertical	Horizontal

\* in gauges required by UL listing R16690



\* These dimensions are furnished approximately 1/4 in. (6mm) undersize.



See complete marking on product.  
 UL 555 Classification R13317

Model FD-350 meets the requirements for fire damper established by:  
**National Fire Protection Association**  
 (NFPA Standards 80, 90A & 101)  
**Underwriters Laboratories Standard 555**  
 (Listing #R13317)  
**IBC International Building Codes**

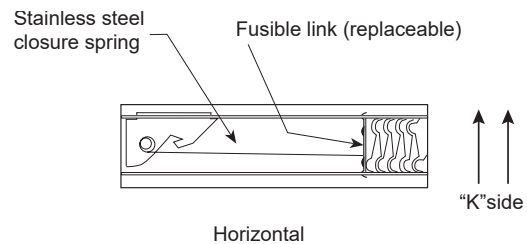
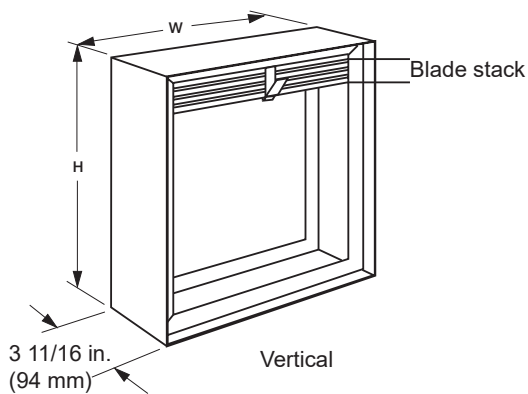

## Options and Accessories

---

- Breakaway connections
- Clean wrap
- Closed indicator switch
- Flanges
- Grille tabs
- Retaining angles
- Security bars
- Sealed transitions and sleeve
- Transitions: B, B2, C, CO, CR, and R

## Document Links

---



[INSTALLATION](#)



[CATALOG](#)



[WARRANTY](#)



[SELECTION GUIDE](#)

## Factory Sleeve Option

All fire damper installations require the use of sleeves, angles and methods described in the installation instructions. Sleeves can be field fabricated or factory furnished as a completed damper/sleeve assembly.

Sleeves are galvanized steel and are available in 20 through 10 ga. (1mm - 3.5mm) thicknesses and lengths up to 36 in. (914mm).

"K" dimension specifies location of damper within the sleeve. Minimum is 4 in. (102mm), maximum is "L" less 4 in. (102mm), which allows for retaining angle installation, and duct connection at each end of the sleeve. If "K" dimension is not specified, it will be provided as one half of "L" dimension (damper centered in sleeve).

**Note: If using access doors, the door should be installed on the "K" side of the damper.**

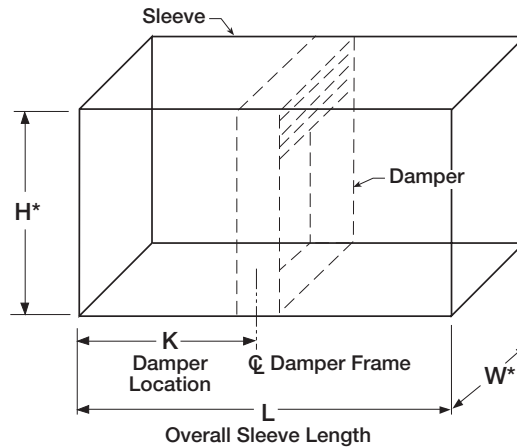

## Sealed Option

When sealed option is selected, damper sleeve will be sealed to the damper frame or selected transition using UL approved sealant. For B transitions, the corners will need to be field sealed in the area where the duct to sleeve connection is made.

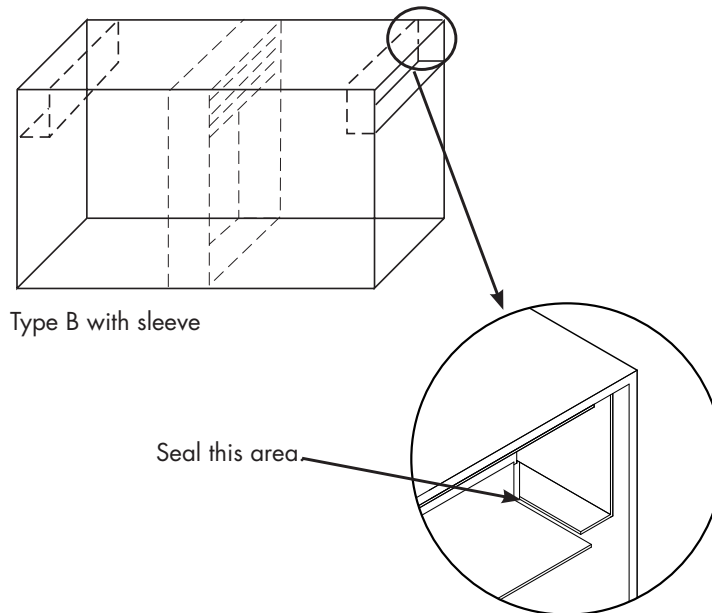

# Type A, B, & B2

Dampers larger than maximum single section size are supplied in 2 or more sections of equal size. Multi-section dampers are factory assembled ready for installation.

## Size Limitations

Inches (mm)	Type A		Type B & B2	
	Minimum	Maximum	Minimum	Maximum
Single Section Vertical	4 x 4 (102 x 102)	48 x 48 (1219 x 1219)	4 x 3 (102 x 76)	48 x 42 (1219 x 1067)
Single Section Horizontal	4 x 4 (102 x 102)	40 x 40 (1016 x 1016)	4 x 3 (102 x 76)	40 x 35 (1016 x 889)
Multi Section Horizontal**	NA	80 X 40 (2032 X 1016)	NA	80 X 35 (2032 X 889)

\*\* Consult factory for number of sections.

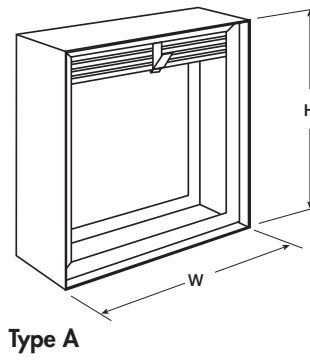

Type A

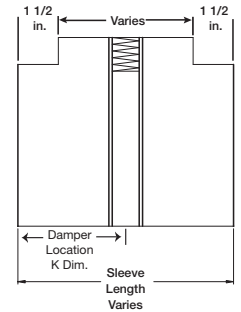

Type B2 side view

### Maximum Single Section Dimensions

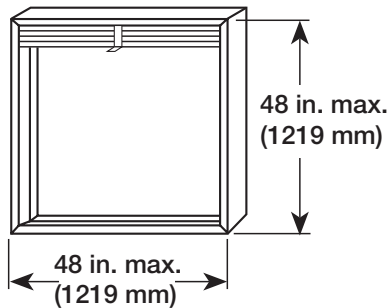

Type A Single Section

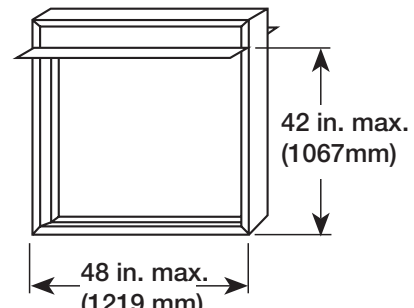

Type B Single Section

### Maximum Multi-Section Dimensions

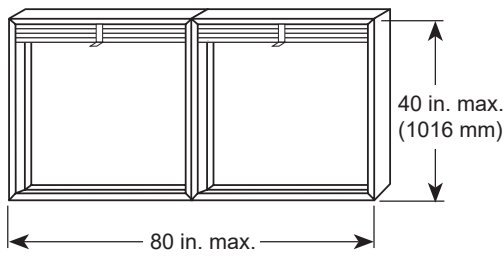

Type A

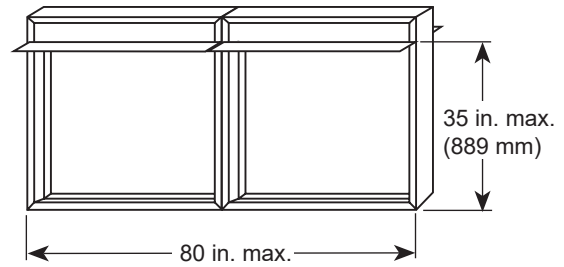

Type B

**Note:** All multi-section dampers with transitions will include a factory sleeve.

## Type B & B2 Overall Dimensions

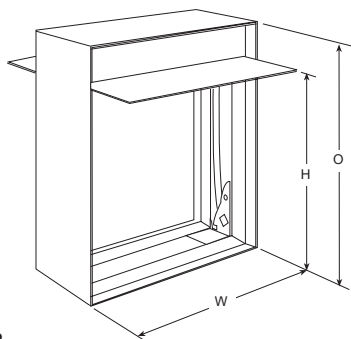

Type B

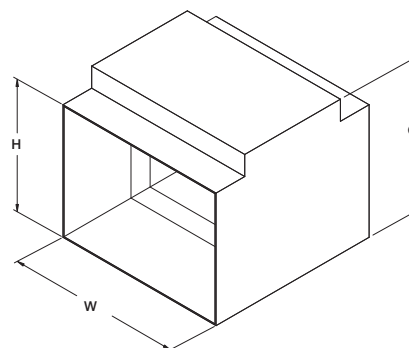

Type B2

H*	O*
3 (76)	5 (127)
4 (102)	6 (152)
5 (127)	7 (178)
6 (152)	8 (203)
7 (178)	9 (229)
8 (203)	10 (254)
9 (229)	11 (279)
10 (254)	12 (305)
11 (279)	13 (330)
12 (305)	14 (356)
13 (330)	15 (381)
14 (356)	16 (406)
15 (381)	18 (457)
16 (406)	19 (483)
17 (432)	20 (508)
18 (457)	21 (533)
19 (483)	22 (559)
20 (508)	23 (584)
21 (533)	24 (610)
22 (559)	26 (660)

H*	O*
23 (584)	27 (686)
24 (610)	28 (711)
25 (635)	29 (737)
26 (660)	30 (762)
27 (686)	31 (787)
28 (711)	32 (813)
29 (737)	33 (838)
30 (762)	34 (864)
31 (787)	36 (914)
32 (813)	37 (940)
33 (838)	38 (965)
34 (864)	39 (991)
35 (889)	40 (1016)
36 (914)	41 (1041)
37 (940)	42 (1067)
38 (965)	44 (1118)
39 (991)	45 (1143)
40 (1016)	46 (1168)
41 (1041)	47 (1194)
42 (1067)	48 (1219)

\* Dimensions are in inches (mm). These dimensions are furnished approximately ¼ in. (6mm) undersize. (All 'H' dimensions larger than single section height are two sections high. Refer to chart.)

# Type C, CO, & CR

Dampers larger than maximum single section size are supplied in 2 or more sections of equal size.

Inches (mm)	Type CR		Type C & CO	
	Minimum	Maximum	Minimum	Maximum
Single Section Vertical	3 (76)	41 (1041)	3 x 3 (76 x 76)	46 x 41 (1168 x 1041)
Single Section Horizontal	3 (76)	34 (864)	3 x 3 (76 x 76)	38 x 34 (965 x 864)
Multi-Section Horizontal**	NA	NA	NA	78 X 34 (1981 X 864)

\*\* Consult factory for number of sections.

Type C

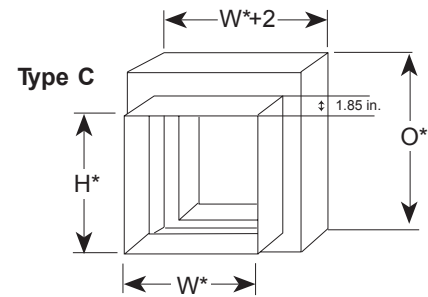
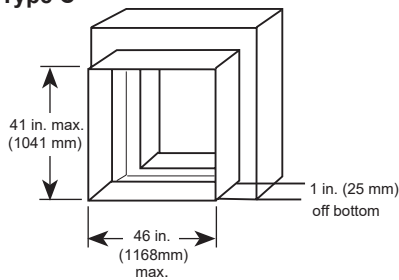

Type CO

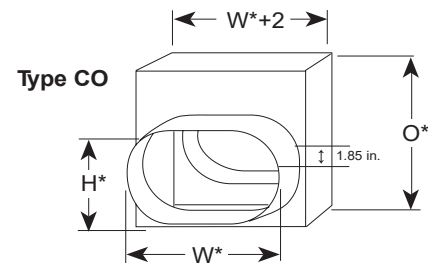
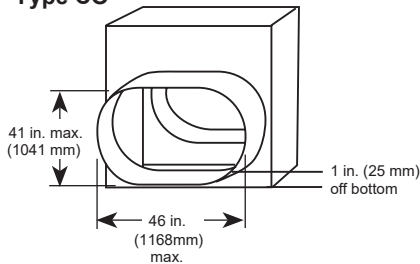

Type CR

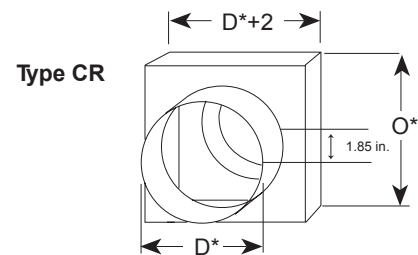
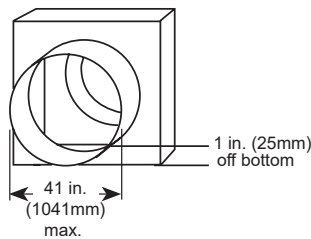

\*See page 7 for O dimension information.

C, CO, CR transitions are positioned 1 in. (25mm) from bottom of sleeve

**Note:** All multiple section dampers with transitions, will include a factory installed sleeve.

## Type C, CO, & CR

H* or D*	O*	H* or D*	O*
3 (76)	6 (152)	23 (584)	28 (711)
4 (102)	7 (178)	24 (610)	29 (737)
5 (127)	8 (203)	25 (635)	30 (762)
6 (152)	9 (229)	26 (660)	31 (787)
7 (178)	10 (254)	27 (686)	32 (813)
8 (203)	11 (279)	28 (711)	33 (838)
9 (229)	12 (305)	29 (737)	34 (864)
10 (254)	13 (330)	30 (762)	36 (914)
11 (279)	14 (356)	31 (787)	37 (940)
12 (305)	15 (381)	32 (813)	38 (965)
13 (330)	16 (406)	33 (838)	39 (991)
14 (356)	18 (457)	34 (864)	40 (1016)
15 (381)	19 (483)	35 (889)	41 (1041)
16 (406)	20 (508)	36 (914)	42 (1067)
17 (432)	21 (533)	37 (940)	44 (1118)
18 (457)	22 (559)	38 (965)	45 (1143)
19 (483)	23 (584)	39 (991)	46 (1168)
20 (508)	24 (610)	40 (1016)	47 (1194)
21 (533)	26 (660)	41 (1041)	48 (1219)
22 (559)	27 (686)		

\* Dimensions are in inches (mm). These dimensions are furnished approximately ¼ in. (6mm) undersize, except round and oval dimensions (D, H, W) are approximately ⅛ in. (3mm) undersize. (All 'H' dimensions larger than single section height are two sections high. Refer to chart.)

## Type R

Inches (mm)	Type R'		
	Minimum	Maximum with 1 in. offset	Maximum with 2 in. offset
Single Section Vertical	3 (76)	47 (1194)	46 (1168)
Single Section Horizontal	NA	39 (991)	38 (965)

Overall Damper Dimensions

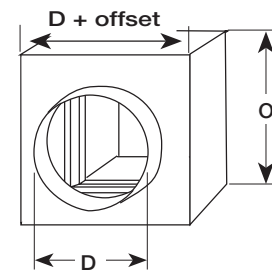

Type R transition is centered in damper sleeve.

To calculate O Dimension:

Diameter + offset (1 or 2 in.) = O Dimension