

Application

Model FSD-311 is a high performance combination fire smoke damper with Class I leakage. High strength airfoil blades ensure the lowest resistance to airflow in HVAC systems with velocities to 4000 fpm (20.3 m/s) and pressures to 8 in. wg (2 kPa). Model FSD-311 may be installed vertically (with blades running horizontal) or horizontally and is rated for airflow and leakage in either direction.

Ratings

UL 555 Fire Resistance Rating

Fire Rating: 1 ½ hours

Dynamic Closure Rating: Actual ratings are size dependent

Velocity: Up to 4000 fpm (20.3 m/s)

Pressure: Up to 8 in. wg (2 kPa)

UL 555S Leakage Rating

Leakage Class: I

Operational Rating: Actual ratings are size dependent

Velocity: Up to 4000 fpm (20.3 m/s)

Pressure: Up to 8 in. wg (2 kPa)

Temperature: Up to 350°F (177°C) - depending upon the actuator



Width and Height dimensions furnished approximately ¼ in. (6mm) undersize. Add sleeve thickness for overall sleeved damper dimension. Right hand drive is shown. Left hand drive is available upon request.



See complete marking on product.

UL 555 and UL 555S
Classification R13317

Size Limitations

W x H	Minimum Size	Maximum Size		
		Single Section	Multiple Section	
			Horizontal	Vertical
Inches	4 x 4*	32 x 50	144 x 96	128 x 100
mm	102 x 102	813 x 1270	3658 x 2438	3251 x 2540

* Overall damper size is 6 in. x 6 in. (152 mm x 152 mm).

Note: Maximum sizes are dependent on velocities and pressure.

Model FSD-311 meets the requirements for fire dampers, smoke dampers and combination fire smoke dampers established by:

National Fire Protection Association

NFPA Standards 80, 90A, 92, 101 & 105

IBC International Building Codes

Construction

	Standard	Optional
Frame Material	Galvanized steel	-
Frame Material Thickness	16 ga. (1.5mm)	-
Frame Type	5 in. x 1 in. (127mm x 25mm) hat channel	-
Blade Action	Opposed	-
Blade Material	Galvanized steel	-
Blade Material Thickness	14 ga. (2mm) equivalent	-
Blade Type	Airfoil	-
Blade Orientation	Horizontal	-
Linkage	Plated steel out of airstream, concealed in jamb	316SS
Axle Bearings	316SS	-
Axle Material	Plated steel	316SS
Blade Seals	Silicone	-
Jamb Seals	Stainless Steel	-
Closure Device	RRL	RRL/OCI, TOR, Fusible Link
Closure Temperature	165°F (74°C)	212°F (100°C), 250°F (121°C), 286°F (141°C)*, 350°F (177°C)
Mounting	Vertical	Horizontal

*only available with fusible link

Note:

The frames are constructed with reinforced corners. Low profile head and sill are used on sizes less than 17 in. (432 mm) high for lower pressure drop and improved damper performance.

Options and Accessories

Click on underline words for more information.

- Access door mounted in a sleeve
- BACnet test module - 120V
- BACnet test module - 24V
- Breakaway connections
- Clean wrap
- GTS test switches
- Grille tabs
- Momentary test switch
- OCI (Open Closed Indicator switch) - available when fusible link is selected
- Retaining angles
- Security bars
- Sealed transitions and sleeve
- Smoke detector - no flow
- Smoke detector - low flow
- Transitions: C, O, R

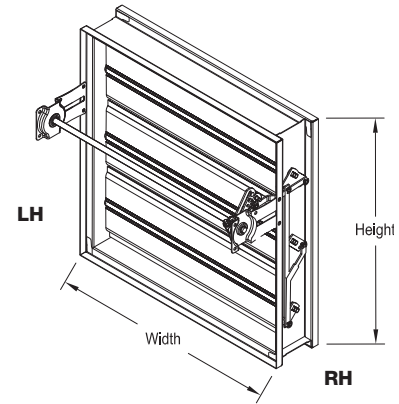

Pressure Drop

AMCA Figure 5.2

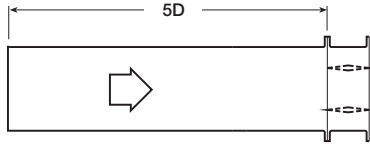

12 in. x 12 in. (305mm x 305mm)

Velocity (fpm)	Pressure Drop (in. wg)
500	0.03
1000	0.11
1500	0.24
2000	0.42
2500	0.66
3000	0.95
3500	1.30
4000	1.70

24 in. x 24 in. (610mm x 610mm)

Velocity (fpm)	Pressure Drop (in. wg)
500	0.01
1000	0.06
1500	0.12
2000	0.22
2500	0.34
3000	0.49
3500	0.67
4000	0.87

36 in. x 36 in. (914mm x 914mm)

Velocity (fpm)	Pressure Drop (in. wg)
500	0.01
1000	0.05
1500	0.12
2000	0.21
2500	0.32
3000	0.47
3500	0.63
4000	0.83

12 in. X 48 in. (305mm x 1219mm)

Velocity (fpm)	Pressure Drop (in. wg)
500	0.01
1000	0.05
1500	0.12
2000	0.21
2500	0.33
3000	0.48
3500	0.65
4000	0.85

48 in. x 12 in. (1219mm x 305mm)

Velocity (fpm)	Pressure Drop (in. wg)
500	0.02
1000	0.08
1500	0.18
2000	0.33
2500	0.51
3000	0.74
3500	1.00
4000	1.31

AMCA Figure 5.3

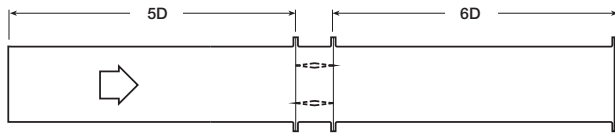

12 in. x 12 in. (305mm x 305mm)

Velocity (fpm)	Pressure Drop (in. wg)
500	0.01
1000	0.06
1500	0.13
2000	0.23
2500	0.37
3000	0.53
3500	0.73
4000	0.95

24 in. x 24 in. (610mm x 610mm)

Velocity (fpm)	Pressure Drop (in. wg)
500	0.01
1000	0.02
1500	0.06
2000	0.10
2500	0.16
3000	0.23
3500	0.32
4000	0.42

36 in. x 36 in. (914mm x 914mm)

Velocity (fpm)	Pressure Drop (in. wg)
500	0.01
1000	0.02
1500	0.05
2000	0.09
2500	0.14
3000	0.21
3500	0.29
4000	0.38

12 in. X 48 in. (305mm x 1219mm)

Velocity (fpm)	Pressure Drop (in. wg)
500	0.01
1000	0.03
1500	0.06
2000	0.11
2500	0.18
3000	0.25
3500	0.34
4000	0.45

48 in. x 12 in. (1219mm x 305mm)

Velocity (fpm)	Pressure Drop (in. wg)
500	0.01
1000	0.04
1500	0.10
2000	0.18
2500	0.29
3000	0.42
3500	0.57
4000	0.74

AMCA Figure 5.5

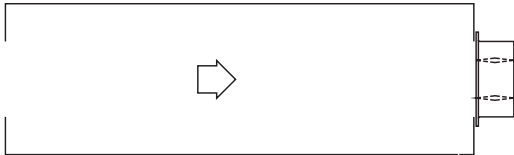

12 in. x 12 in. (305mm x 305mm)

Velocity (fpm)	Pressure Drop (in. wg)
500	0.04
1000	0.18
1500	0.42
2000	0.75
2500	1.17
3000	1.68
3500	2.29
4000	2.09

24 in. x 24 in. (610mm x 610mm)

Velocity (fpm)	Pressure Drop (in. wg)
500	0.03
1000	0.13
1500	0.29
2000	0.52
2500	0.81
3000	1.17
3500	1.60
4000	2.14

36 in. x 36 in. (914mm x 914mm)

Velocity (fpm)	Pressure Drop (in. wg)
500	0.03
1000	0.12
1500	0.27
2000	0.48
2500	0.75
3000	1.08
3500	1.48
4000	1.93

12 in. X 48 in. (305mm x 1219mm)

Velocity (fpm)	Pressure Drop (in. wg)
500	0.03
1000	0.12
1500	0.27
2000	0.49
2500	0.77
3000	1.11
3500	1.51
4000	1.97

48 in. x 12 in. (1219mm x 305mm)

Velocity (fpm)	Pressure Drop (in. wg)
500	0.03
1000	0.14
1500	0.32
2000	0.57
2500	0.89
3000	1.28
3500	1.75
4000	2.29

Space Envelopes

Externally mounted actuators always require space outside of the damper sleeve. The “S” dimension illustrates the clearance required for various available actuators.

Worst case space envelopes shown below. Exact dimensions may vary based on specific damper configuration. Consult factory for specific space envelope if necessary.

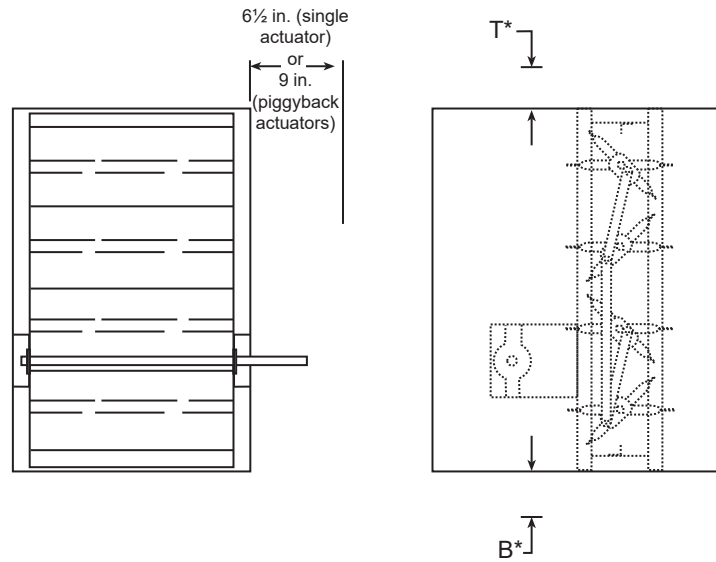

Actuator Type/Model	B*	T*	S	
	With RRL, RRL/OCI, or TOR	With RRL, RRL/OCI, or TOR	Piggyback	
			No	Yes
Belimo				
FSAFB24-SR (-S)	1 1/2 in. (38mm)	9 1/4 in. (235mm)	6 in. (152mm)	9 in. (229mm)
FSLF series	8 in. (203mm)	1 1/2 in. (38mm)	6 1/2 in. (165mm)	NA
FSNF series	1 1/2 in. (38mm)	9 1/4 in. (235mm)	6 in. (152mm)	9 in. (229mm)
FSTF Series	8 in. (203mm)	1 1/2 in. (38mm)	6 1/2 in. (165mm)	NA
Siemens				
GJD Series	7 in. (178mm)	1 1/2 in. (38mm)	6 1/2 in. (165mm)	NA
GRD Series	1 1/2 in. (38mm)	7 1/2 in. (191mm)	6 1/2 in. (165mm)	NA
GXVD Series	1 1/2 in. (38mm)	9 1/4 in. (235mm)	6 in. (152mm)	9 in. (229mm)
Honeywell				
MS4103, MS8103 Series	8 3/4 in. (222mm)	1 1/2 in. (38mm)	6 1/2 in. (165mm)	NA
MS4104, MS4604, MS8104 Series	1 1/2 in. (38mm)	8 1/2 in. (216mm)	6 1/2 in. (165mm)	NA
MS4109, MS4609, MS8109 Series	1 1/2 in. (38mm)	8 1/2 in. (216mm)	6 1/2 in. (165mm)	NA
MS4120, MS4620, MS8120 Series	1 1/2 in. (38mm)	9 1/2 in. (241mm)	6 in. (152mm)	9 in. (229mm)

* For dampers 18 in. (457mm) or more in height these dimensions are 0 in.

Contained Actuator Option

Dampers can be ordered with a "contained actuator option". This option will result in the actuator being oriented such that it extends no more than 1½ inches above or below the sleeve. Note that some damper configurations that are 11 inches high or less will have the RRL, RRL/OCI, or TOR mounted on the side opposite the actuator when the contained actuator option is selected.

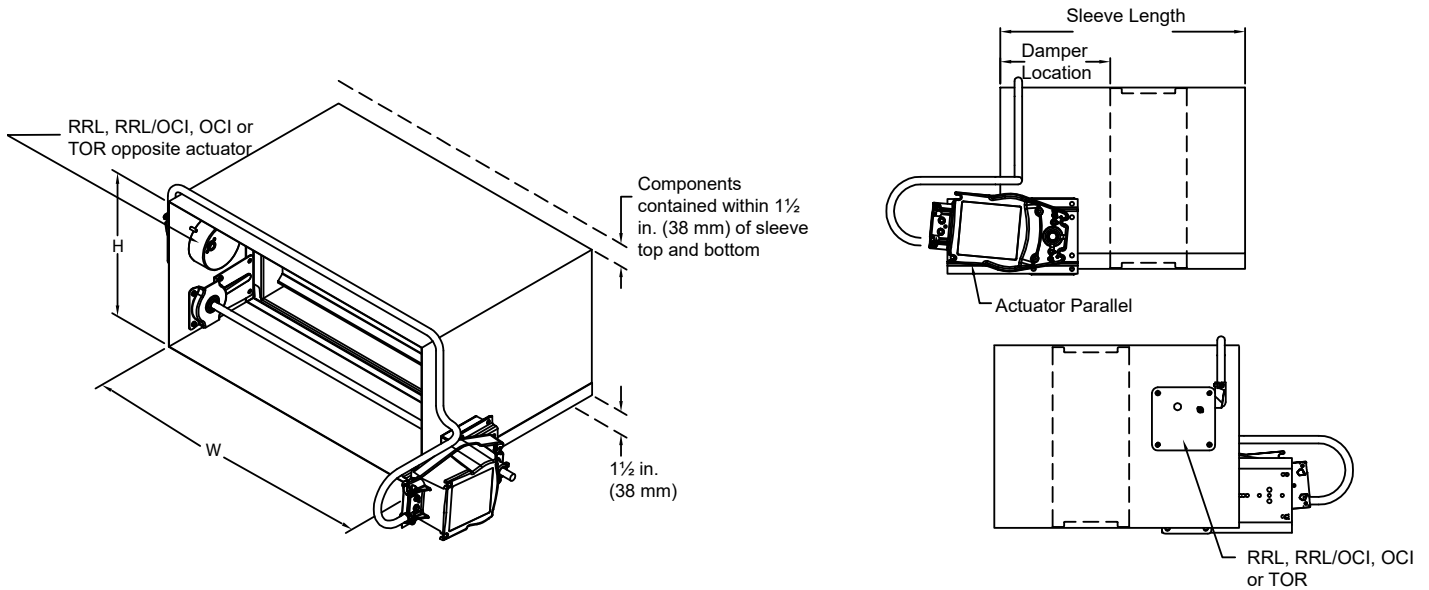

Sleeve and Sideplate Dimensional Data

The drawings below and corresponding table show the position of the FSD-311 damper when mounted in a factory sleeve ("A" dimension). The standard mounting locations provide enough space for the mounting of actuators, controls and allow space for installation of retaining angles and duct connections. The following options may affect the range of available mounting locations: smoke detector, NEMA 7 enclosure, transitions, security bars, grille tabs.

The standard location of a damper mounted in a factory sleeve ("A" dimension) is shown below. The damper can be positioned at other locations within a range of 6 in. (152mm) to 16 in. (406mm) for the "A" dimension.

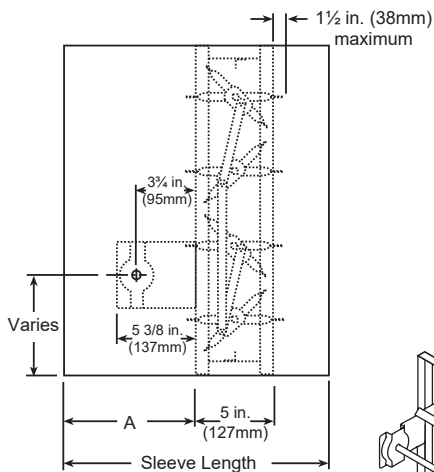

in. (mm)	With Sleeve		Sideplate Damper Location "A"
	Minimum Damper Location "A"	Maximum Damper Location "A"	
Compact configuration*	7 3/16 in. (183)	16 (406)	-
Standard (non-compact) Height < 12 in. (305) RRL, RRL/OCI, or TOR	12 (305)	16 (406)	12 (305)
Standard (non-compact) Height ≥ 12 in. (305) RRL, RRL/OCI, or TOR	7 3/16 in. (183)	16 (406)	12 (305)

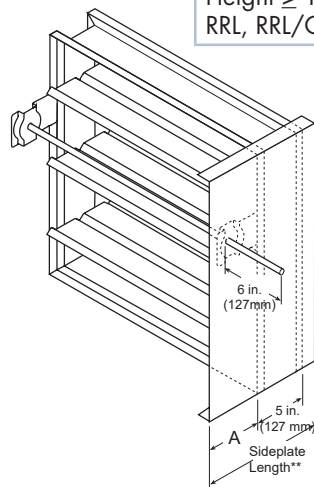

* Contact factory for more information.

NOTE: Entire damper frame is not required to be installed within the wall. The damper blades, when closed should be contained within the wall.

Transitioned Damper Dimensions

When a combination fire smoke damper is being used in conjunction with round or oval ductwork, the FSD-311 can be supplied in a factory sleeve with round or oval transitions on both ends of the sleeve. Dampers should be ordered to the duct dimensions. Drawings below show overall damper size.

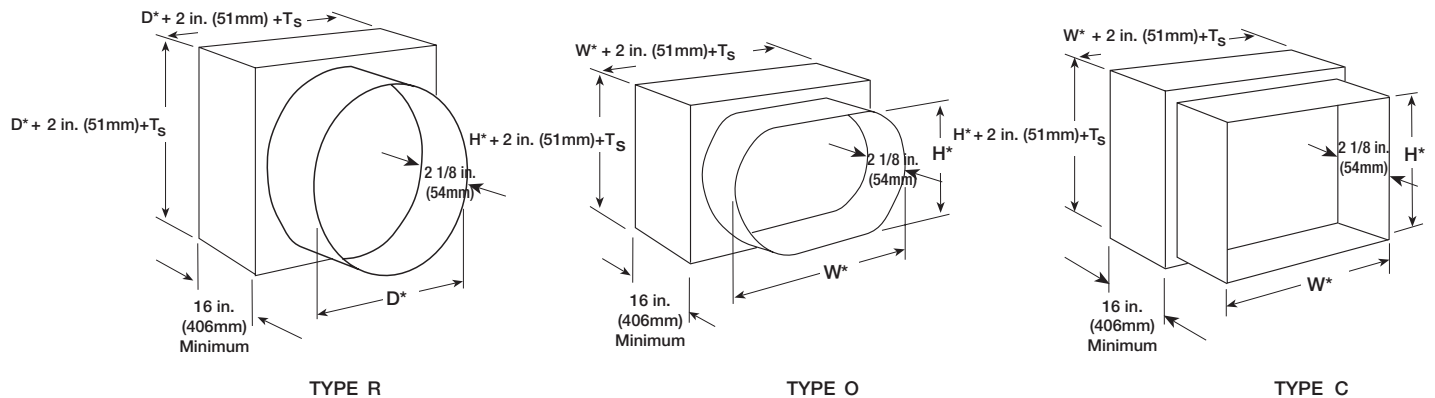

*These dimensions are furnished approximately 1/4 in. (6mm) undersize, except round and oval dimensions which are approximately 1/8 in. (3mm) undersize.

Ts = (2)(Sleeve Thickness)

Multiple Sections Damper

Dampers larger than maximum single section size are supplied as a factory assembly of two or more sections of equal size. The following figures show maximum damper section size and assembly configurations for multi-section dampers.

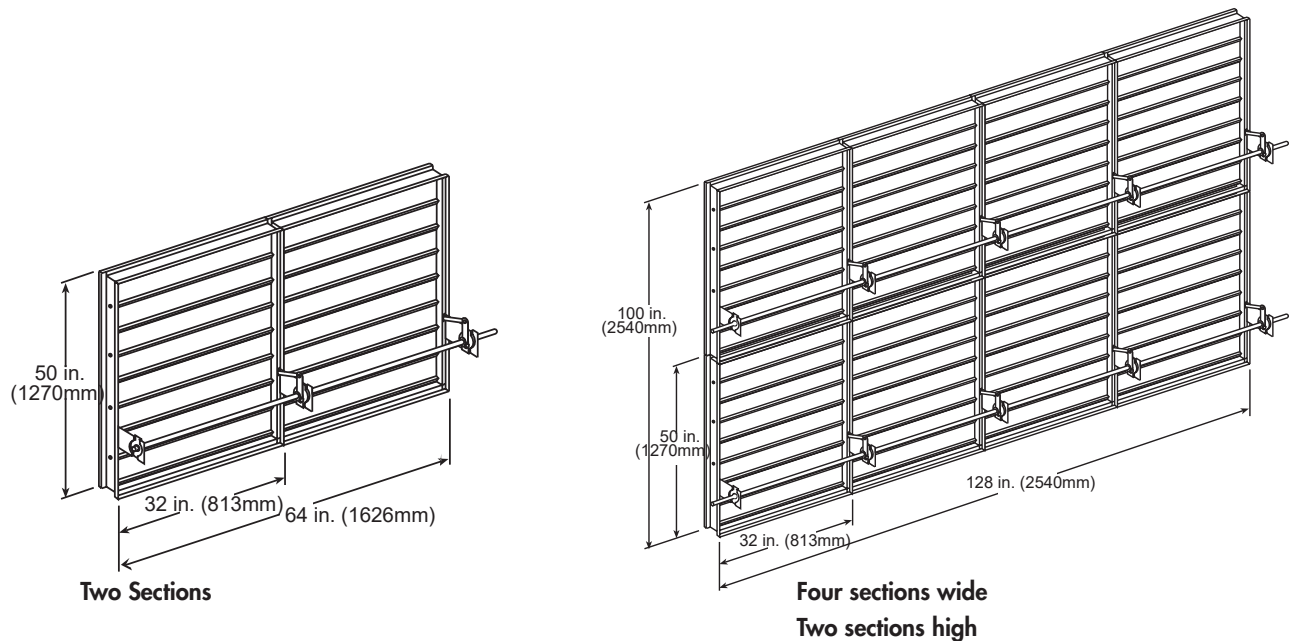

Document Links



[INSTALLATION](#)



[CATALOG](#)



[WARRANTY](#)



Copyright © 2024 Venco Products

FSD-311, R10, September 2024

Venco Products reserves the right to make product changes without notice.