

### Application

Model FSD-331 is a combination fire smoke damper with Class I leakage and 3 hour fire rating. High strength airfoil blades ensure the lowest resistance to airflow in HVAC systems with velocities to 4000 fpm (20.3 m/s) and pressures up to 8 in. wg (2 kPa). Model FSD-331 may be installed vertically or horizontally (with blades running horizontal) and is rated for airflow and leakage in either direction.

### Ratings

#### UL 555 Fire Resistance Rating

Fire Rating: 3 hours

Dynamic Closure Rating: Actual ratings are size dependent

Velocity: Up to 4000 fpm (20.3 m/s)

Pressure: Up to 8 in. wg (2 kPa)

#### UL 555S Leakage Rating

Leakage Class: I

Operational Rating: Actual ratings are size dependent

Velocity: Up to 4000 fpm (20.3 m/s)

Pressure: Up to 8 in. wg (2 kPa)

Temperature: Up to 350°F (177°C) - depending upon the actuator



Width and Height dimensions furnished approximately 1/4 in. (6 mm) undersize. (Add sleeve thickness for overall sleeved damper dimension). External right hand drive is shown.



See complete marking on product.

UL 555 and UL 555S Classification R13317

CAN/ULC S112 Classified Fire Damper

CAN/ULC S112.1 Classified Smoke Damper

### Size Limitations

W x H	Minimum Size	Maximum Size	
		Single Section	Multiple Section
Inches	4 x 4*	32 x 36 (V) or 30 x 48 (H or V)	120 x 96 (V) or 120 x 96 (H)
mm	102 x 102	813 x 1270 (V) or 762 x 1219 (H or V)	3048 x 2438 (V) or 3048 x 2438 (H)

\* Overall damper size is 6 in. x 6 in. (152 mm x 152 mm)

**Note:** Maximum sizes are dependent on velocities and pressure.

Model FSD-331 meets the requirements for fire dampers, smoke dampers and combination fire smoke dampers established by:

**National Fire Protection Association**  
NFPA Standards 80, 90A, 92, 101, & 105

**IBC International Building Codes**

## Construction

	Standard	Optional
<b>Frame Material</b>	Galvanized steel	-
<b>Frame Material Thickness</b>	16 ga. (1.5mm)	-
<b>Frame Type</b>	5 in. x 1 in. (127 mm x 25 mm) hat channel	-
<b>Blade Action</b>	Opposed	-
<b>Blade Material</b>	Galvanized steel	-
<b>Blade Material Thickness</b>	14 ga. (2 mm) equivalent	-
<b>Blade Type</b>	Airfoil	-
<b>Blade Orientation</b>	Vertical	Horizontal
<b>Linkage</b>	Plated steel out of airstream, concealed in jamb	316SS
<b>Axle Bearings</b>	316SS	-
<b>Axle Material</b>	Plated steel	316SS
<b>Blade Seals</b>	Silicone	-
<b>Jamb Seals</b>	Stainless Steel	-
<b>Closure Device</b>	RRL	RRL/OCI, TOR, Fusible Link*
<b>Closure Temperature</b>	165°F (74°C)	212°F (100°C), 250°F (121°C), 286°F (141°C)*, 350°F (177°C)
<b>Mounting</b>	Horizontal	-

\*only available with fusible link

### Features:

The frames are constructed with reinforced corners. Low profile head and sill are used on sizes less than 17 in. (432 mm) high for lower pressure drop and improved damper performance.

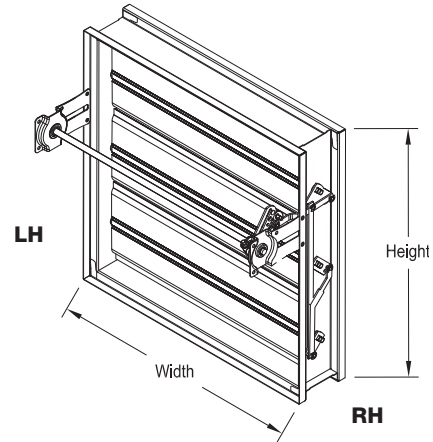

## Options

- BACnet test module - 120V or 24V
- Breakaway connections
- Clean wrap
- GTS test switches
- Grille tabs
- Momentary test switch
- OCI (Open Closed Indicator switch) - available when fusible link is selected
- Retaining angles
- Security bars
- Sealed transitions and sleeve
- Smoke detectors - no flow or low flow
- Transitions: C, O, R

# Pressure Drop

AMCA Figure 5.2

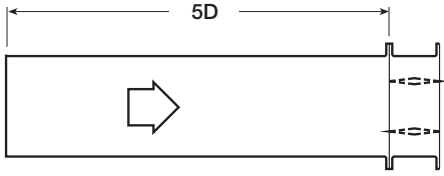

12 in. x 12 in. (305 mm x 305 mm)

Velocity (fpm)	Pressure Drop (in. wg)
500	0.03
1000	0.11
1500	0.24
2000	0.42
2500	0.66
3000	0.95
3500	1.30
4000	1.70

24 in. x 24 in. (610 mm x 610 mm)

Velocity (fpm)	Pressure Drop (in. wg)
500	0.01
1000	0.06
1500	0.12
2000	0.22
2500	0.34
3000	0.49
3500	0.67
4000	0.87

36 in. x 36 in. (914 mm x 914 mm)

Velocity (fpm)	Pressure Drop (in. wg)
500	0.01
1000	0.05
1500	0.12
2000	0.21
2500	0.32
3000	0.47
3500	0.63
4000	0.83

12 in. x 48 in. (305 mm x 1219 mm)

Velocity (fpm)	Pressure Drop (in. wg)
500	0.01
1000	0.05
1500	0.12
2000	0.21
2500	0.33
3000	0.48
3500	0.65
4000	0.85

48 in. x 12 in. (1219 mm x 305 mm)

Velocity (fpm)	Pressure Drop (in. wg)
500	0.02
1000	0.08
1500	0.18
2000	0.33
2500	0.51
3000	0.74
3500	1.00
4000	1.31

AMCA Figure 5.3

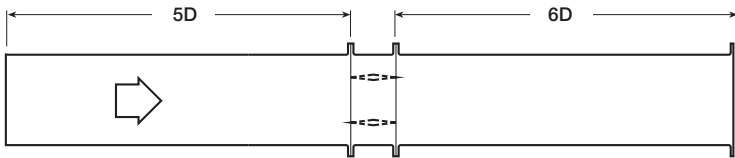

12 in. x 12 in. (305 mm x 305 mm)

Velocity (fpm)	Pressure Drop (in. wg)
500	0.01
1000	0.06
1500	0.13
2000	0.23
2500	0.37
3000	0.53
3500	0.73
4000	0.95

24 in. x 24 in. (610 mm x 610 mm)

Velocity (fpm)	Pressure Drop (in. wg)
500	0.01
1000	0.02
1500	0.06
2000	0.10
2500	0.16
3000	0.23
3500	0.32
4000	0.42

36 in. x 36 in. (914 mm x 914 mm)

Velocity (fpm)	Pressure Drop (in. wg)
500	0.01
1000	0.02
1500	0.05
2000	0.09
2500	0.14
3000	0.21
3500	0.29
4000	0.38

12 in. X 48 in. (305 mm x 1219 mm)

Velocity (fpm)	Pressure Drop (in. wg)
500	0.01
1000	0.03
1500	0.06
2000	0.11
2500	0.18
3000	0.25
3500	0.34
4000	0.45

48 in. x 12 in. (1219 mm x 305 mm)

Velocity (fpm)	Pressure Drop (in. wg)
500	0.01
1000	0.04
1500	0.10
2000	0.18
2500	0.29
3000	0.42
3500	0.57
4000	0.74

AMCA Figure 5.5

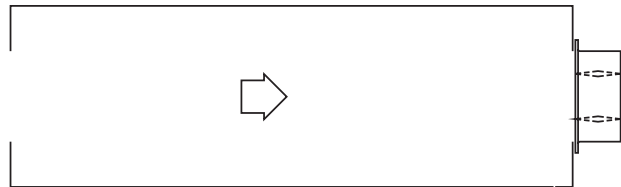

12 in. x 12 in. (305 mm x 305 mm)

Velocity (fpm)	Pressure Drop (in. wg)
500	0.04
1000	0.18
1500	0.42
2000	0.75
2500	1.17
3000	1.68
3500	2.29
4000	2.09

24 in. x 24 in. (610 mm x 610 mm)

Velocity (fpm)	Pressure Drop (in. wg)
500	0.03
1000	0.13
1500	0.29
2000	0.52
2500	0.81
3000	1.17
3500	1.60
4000	2.14

36 in. x 36 in. (914 mm x 914 mm)

Velocity (fpm)	Pressure Drop (in. wg)
500	0.03
1000	0.12
1500	0.27
2000	0.48
2500	0.75
3000	1.08
3500	1.48
4000	1.93

12 in. X 48 in. (305 mm x 1219 mm)

Velocity (fpm)	Pressure Drop (in. wg)
500	0.03
1000	0.12
1500	0.27
2000	0.49
2500	0.77
3000	1.11
3500	1.51
4000	1.97

48 in. x 12 in. (1219 mm x 305 mm)

Velocity (fpm)	Pressure Drop (in. wg)
500	0.03
1000	0.14
1500	0.32
2000	0.57
2500	0.89
3000	1.28
3500	1.75
4000	2.29

# Space Envelopes

Externally mounted actuators always require space outside of the damper sleeve. The “S” dimension illustrates the clearance required for various available actuators.

Worst case space envelopes shown below. Exact dimensions may vary based on specified damper configuration. Consult factory for specific space envelope if necessary.

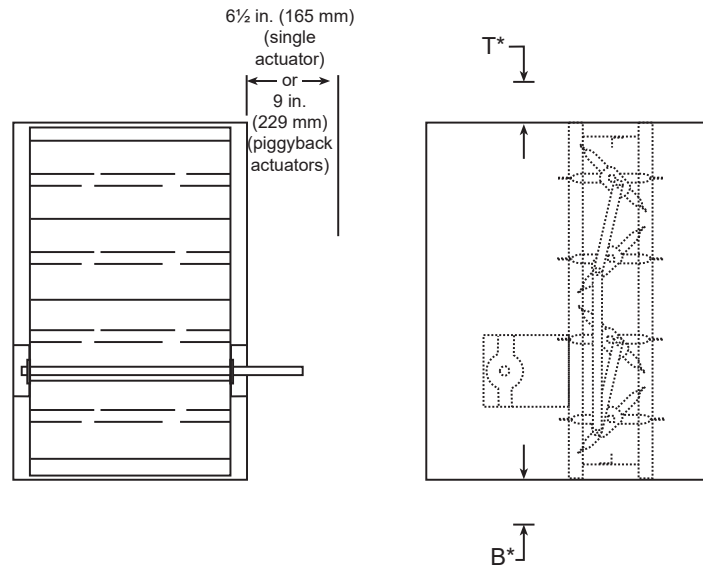

Actuator Type/Model	B*		S	
	With RRL, RRL/OCI, or TOR	With RRL, RRL/OCI, or TOR	Piggyback	
			No	Yes
Belimo				
FSAFB24-SR (-S)	1 1/2 in (38 mm)	9 1/4 in. (235 mm)	6 in. (152 mm)	9 in. (229 mm)
FSLF series	8 in. (203 mm)	1 1/2 in (38 mm)	6 1/2 in. (165 mm)	NA
FSNF series	1 1/2 in (38 mm)	9 1/4 in. (235 mm)	6 in. (152 mm)	9 in. (229 mm)
FSTF Series	8 in. (203 mm)	1 1/2 in (38 mm)	6 1/2 in. (165 mm)	NA
Siemens				
GJD Series	7 in. (178 mm)	1 1/2 in (38 mm)	6 1/2 in. (165 mm)	NA
GRD Series	1 1/2 in (38 mm)	7 1/2 in (191 mm)	6 1/2 in. (165 mm)	NA
GXVD Series	1 1/2 in (38 mm)	9 1/4 in. (235 mm)	6 in. (152 mm)	9 in. (229 mm)
Honeywell				
MS4103, MS8103 Series	8 3/4 in. (222 mm)	1 1/2 in (38 mm)	6 1/2 in. (165 mm)	NA
MS4104, MS4604, MS8104 Series	1 1/2 in (38 mm)	8 1/2 in (216 mm)	6 1/2 in. (165 mm)	NA
MS4109, MS4609, MS8109 Series	1 1/2 in (38 mm)	8 1/2 in (216 mm)	6 1/2 in. (165 mm)	NA
MS4120, MS4620, MS8120 Series	1 1/2 in (38 mm)	9 1/2 in. (241 mm)	6 in. (152 mm)	9 in. (229 mm)

\* For dampers 18 in. (457 mm) or more in height these dimensions are 0 in.

# Contained Actuator Option

Dampers can be ordered with a “contained actuator option”. This option will result in the actuator being oriented such that it extends no more than 1½ inches (38 mm) above or below the sleeve. Note that some damper configurations that are 11 inches (279 mm) high or less will have the RRL, RRL/OCI, or TOR mounted on the side opposite the actuator when the contained actuator option is selected.

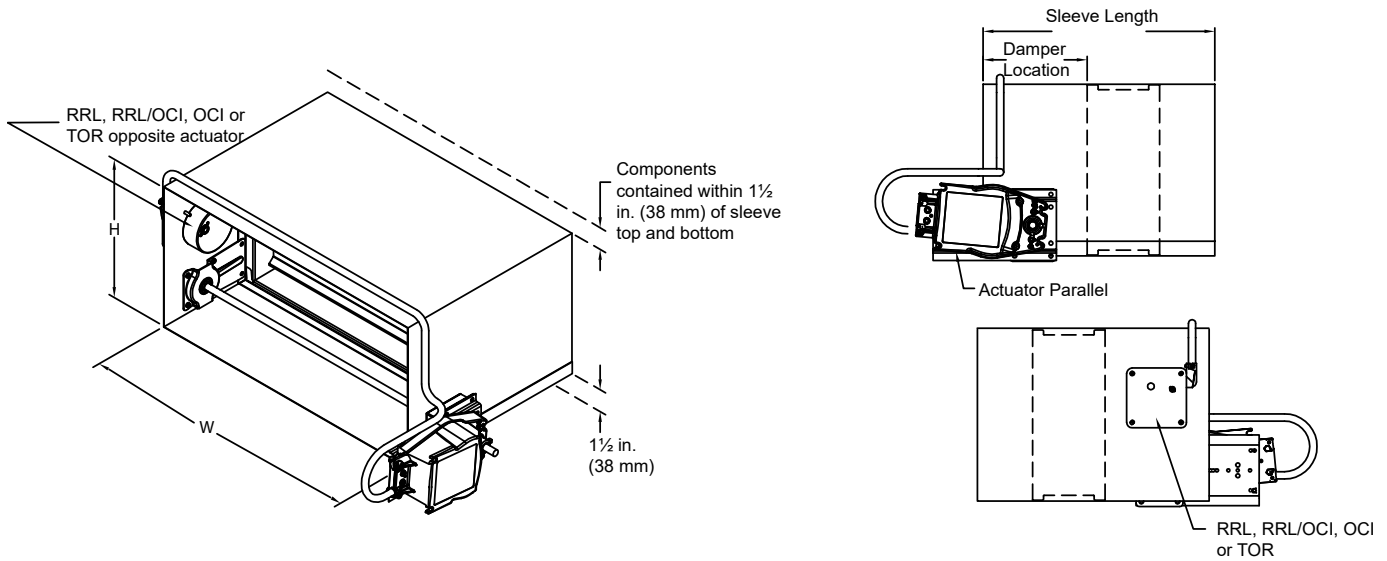

# Sleeve and Sideplate Dimensional Data

The drawings below and corresponding table show the position of the FSD-331 damper when mounted in a factory sleeve ("A" dimension). The standard mounting locations provide enough space for the mounting of actuators, controls and allow space for installation of retaining angles and duct connections. The following options may affect the range of available mounting locations: smoke detector, NEMA 7 enclosure, transitions, security bars, grille tabs.

The standard location of a damper mounted in a factory sleeve ("A" dimension) is shown below. The damper can be positioned at other locations within a range of 6 in. (152 mm) to 16 in. (406 mm) for the "A" dimension.

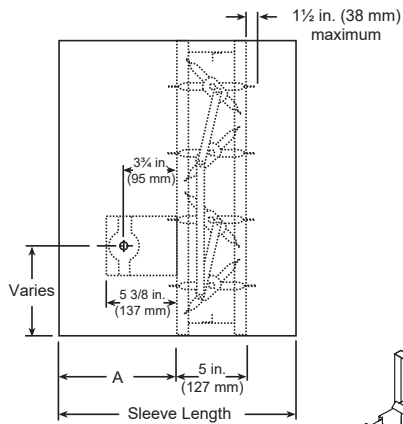

Sleeve

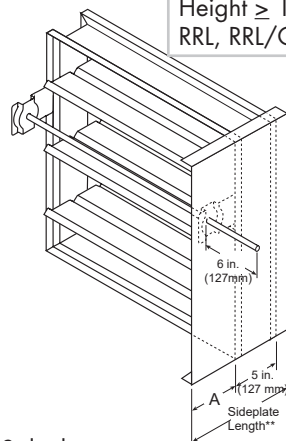

Sideplate

in. (mm)	With Sleeve		Sideplate Damper Location "A"
	Minimum Damper Location "A"	Maximum Damper Location "A"	
Compact configuration *	7 3/16 in. (183)	16 (406)	-
Standard (non-compact) Height < 12 in. (305) RRL, RRL/OCI, or TOR	12 (305)	16 (406)	12 (305)
Standard (non-compact) Height ≥ 12 in. (305) RRL, RRL/OCI, or TOR	7 3/16 in. (183)	16 (406)	12 (305)

\* Contact factory for more information.

**NOTE:** Entire damper frame is not required to be installed within the wall. The damper blades, when closed should be contained within the wall.

## Transitioned Damper Dimensions

When a fire/smoke damper is being used in conjunction with round or oval ductwork, the FSD-331 can be supplied in a factory sleeve with round or oval transitions on both ends of the sleeve. Dampers should be ordered to the duct dimensions. Drawings below show overall damper size.

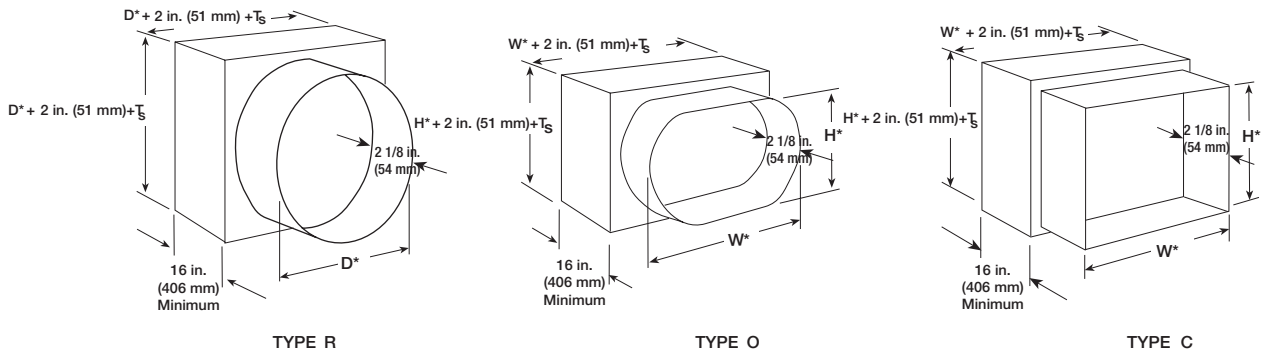

\* These dimension are furnished approximately 1/4 in. (6mm) undersize, except round and oval dimensions which are approximately 1/8 in. (3mm) undersize.

$T_s = (2)(\text{Sleeve Thickness})$

## Multiple Section Damper

Dampers larger than maximum single section size are supplied as a factory assembly of two or more sections of equal size. The following figures show maximum damper section size and assembly configurations for multi-section dampers.

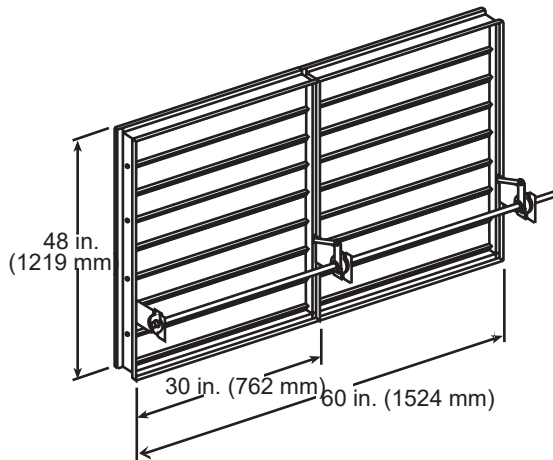

Two Sections

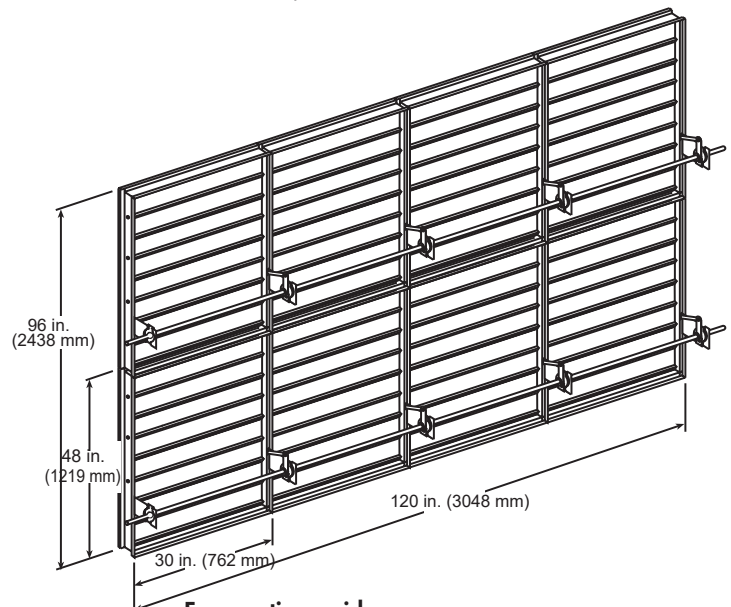

Four sections wide  
Two sections high

## Document Links

---



INSTALLATION



CATALOG



SELECTION GUIDE



WARRANTY