

Application

Model FSDR-511 is a combination fire smoke damper with round style blades. The FSDR-511 is qualified to 4,000 fpm (20.3 m/s) and 4 in. wg (1kPa) for operation and dynamic closure in emergency fire smoke situations. Model FSDR-511 may be installed vertically (with blades running horizontal) or horizontally and is rated for airflow and leakage in either direction.

Ratings

UL 555 Fire Resistance Rating

Fire Rating: 1 ½ hours

Dynamic Closure Rating: Actual ratings are size dependent

Velocity: Up to 4000 fpm (20.3 m/s)

Pressure: Up to 4 in. wg (1 kPa)

UL 555S Leakage Rating

Leakage Class: I

Operational Rating: Actual ratings are size dependent

Velocity: Up to 4000 fpm (20.3 m/s)

Pressure: Up to 4 in. wg (1 kPa)

Temperature: Up to 350°F (177°C) - depending upon the actuator



*Dimensions furnished approximately 1/8 in. (3mm) undersize.



See complete marking on product.

UL 555 and UL 555S
Classification R16690

Construction

	Standard	Optional
Frame Material	Galvanized steel	-
Frame Material Thickness	20 ga. (1 mm)	16 ga. (1.5 mm)
Blade Material	Double skin galvanized steel	-
Blade Material Thickness	14 ga. (2mm) equivalent	-
Blade Seal	Silicone	-
Axle Bearings	Bronze	316SS
Axle Material	½ in. (13 mm) plated steel	316SS
Closure Device	Fusible Link	RRL, RRL/OCI, TOR
Closure Temperature	165°F (74°C)	212°F (100°C), 250°F (121°C), 286°F (141°C), 350°F (177°C)

Model FSDR-511 meets the requirements for fire dampers, smoke dampers and combination fire smoke dampers established by:

National Fire Protection Association

NFPA Standards 80, 90A, 92, 101 & 105

IBC International Building Codes

Size Limitations

Diameter	Minimum Size	Maximum Size
Inches	6	24
mm	152	610

Options

- Electric actuators to accomplish smoke management and system functions
- One retainer plate required, additional retainer plate available
- Greenheck Test Switches (GTS)
- OCI (Open Closed Indication switches)
- Momentary switch
- Smoke Detectors

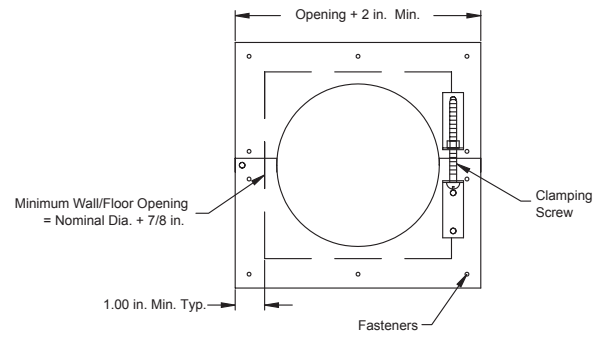

Document Links



[INSTALLATION](#)



[CATALOG](#)



[SELECTION GUIDE](#)



[WARRANTY](#)

Pressure Drop Data

This pressure drop testing was conducted in accordance with AMCA Standard 500-D using the configuration shown. All data has been corrected to represent standard air at a density of $.075 \text{ lb/ft}^3$ (1.201 kg/m^3).

Actual pressure drop found in any HVAC system is a combination of many factors. This pressure drop information along with an analysis of other system influences should be used to estimate actual pressure losses for a damper installed in a given HVAC system.

AMCA Test Figures

Figure 5.3 illustrates a fully ducted damper. This configuration has the lowest pressure drop of the three test configurations because entrance and exit losses are minimized by straight duct runs upstream and downstream of the damper.

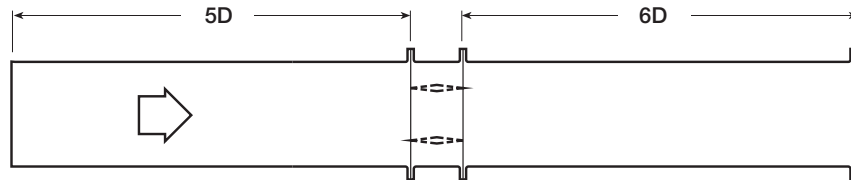
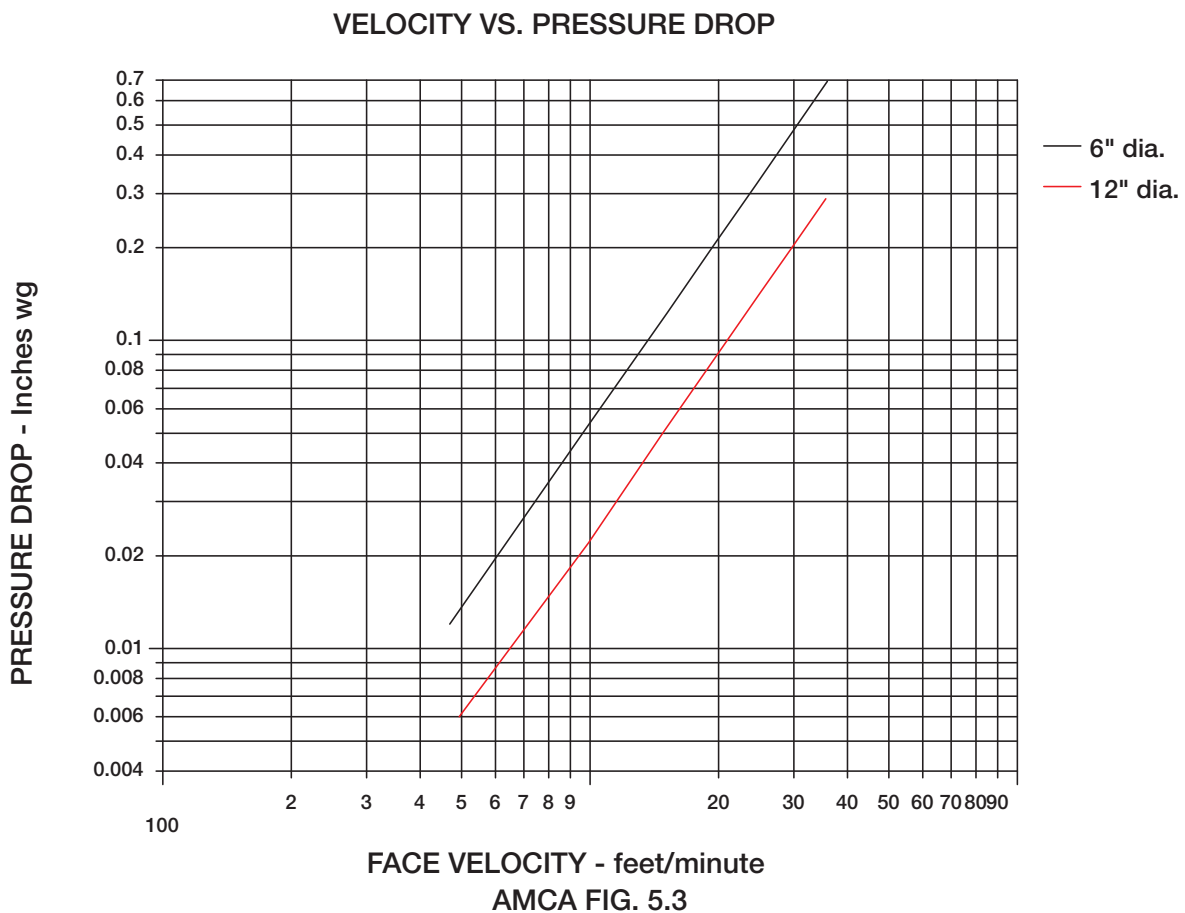
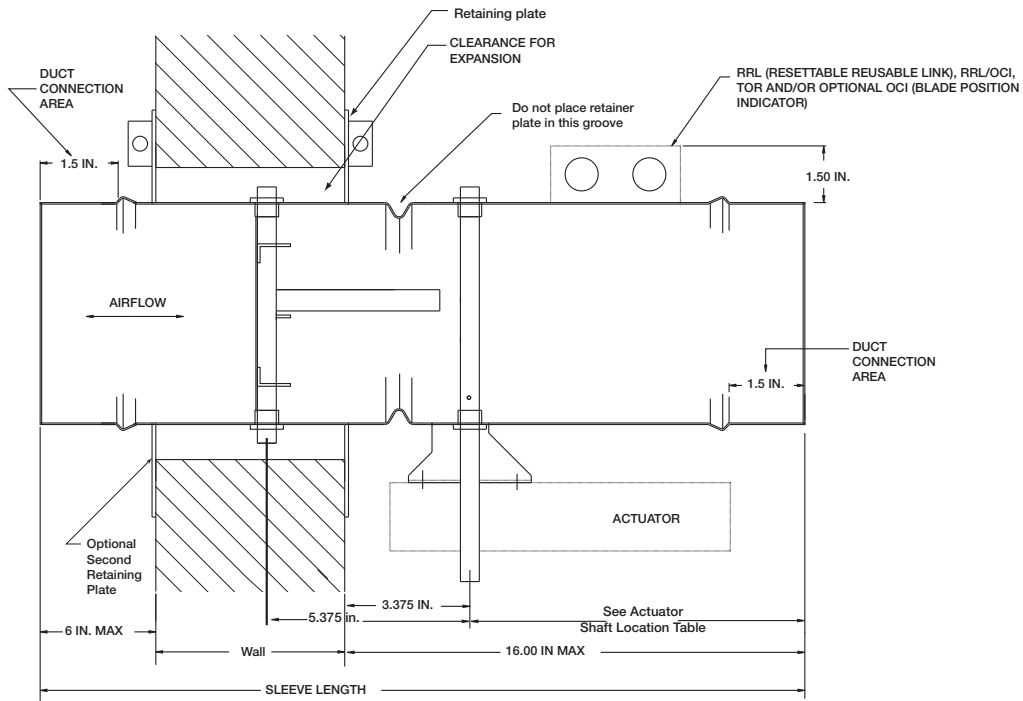

Figure 5.3



Sleeve Length and Actuator Shaft Location

Wall Thickness	Sleeve Length		
	Fusible Link	RRL	RRL/OCI, TOR, OCI
Up to 6½ in.	16 in.	18 in.	20 in.
Up to 8½ in.	18 in.	20 in.	22 in.
Up to 10½ in.	17 5⁄8 in.	22 in.	24 in.
Over 10½ in.	Consult Greenheck		



TOP VIEW OF DAMPER

Actuator Shaft Location (in inches)				
Control Device	Diameter (in inches)			
	≥ 6 to ≤ 10 1⁄8	> 10 1⁄8 to ≤ 11 1⁄8	> 11 1⁄8 to ≤ 14 1⁄8	> 14 1⁄8
Fusible Link	3 1⁄16	3 1⁄16	3 1⁄16	3 1⁄16
RRL	5 11⁄16	4 11⁄16	4 11⁄16	4 11⁄16
RRL/OCI	7 7⁄16	7 7⁄16	7 7⁄16	7 7⁄16
TOR	7 7⁄16	7 7⁄16	7 7⁄16	7 7⁄16