

Application

Model HB-240 is a heavy duty backdraft damper with a double flanged galvanized steel channel frame and extruded airfoil blades. It is designed to prevent backflow and to provide shutoff in HVAC or industrial process systems.

Optional spark resistant 'A' construction meets the spirit of AMCA Standard 99-0401 with all components in the airstream being non-ferrous. Spark 'B' & 'C' construction require blades to be non-ferrous. AMCA Standard 99-041 as written applies to fans ONLY.

Ratings

- Velocity**
Up to 5150 fpm (26.2 m/s)
- Temperature**
-40° to 250°F (-40° to 121°C)
- Pressure**
Up to 13.5 in. wg (3.4 kPa) - differential pressure



- * Actual inside dimension.
- *** RH counterbalance is standard.
- **** Counterbalance weights extend beyond inlet flange in the open position.

	Spark B & C Resistant (Standard)		Spark A Resistant (Optional)*	
	Standard	Optional	Standard	Optional
Frame Material	Galvanized Steel	304SS, 316SS, Aluminum, Carbon Steel	Aluminum	
Frame Type	Flanged Channel		Flanged Channel	
Frame Gauge	14 ga. (2mm)	10 ga. (3.5mm), 12 ga. (2.7mm), 0.125 in. (3mm)	0.125 in. (3mm)	
Frame Depth	8 in. (203mm)	8 in. - 12 in. (203mm - 305mm)	8 in. (203mm)	8 in. - 12 in. (203mm - 305mm)
Blade Material	Aluminum		Aluminum	
Blade Type	Extruded Airfoil		Extruded Airfoil	
Blade Gauge	.080 in. (2mm)		.080 in. (2mm)	
Blade Seals	Silicone	EPDM, None	Silicone	EPDM, None
Flange Width	2 in. (51mm)	1 ½ in. (38mm)	2 in. (51mm)	1 ½ in. (38mm)
Axle Bearing	Galvanized Ball	External Ball	External Galvanized Ball	-
Axle Diameter	¾ in. (19mm)	-	¾ in. (19mm)	-
Axle Material	Plated Steel	303SS or 316SS	Aluminum	
Linkage	External heavy duty type with galvanized steel clevis arms and plated steel tie bars & pivot pins with nylon pivot bearings	304SS or 316SS	External heavy duty type with galvanized steel clevis arms and plated steel tie bars & pivot pins with nylon pivot bearings	
Air Flow	-	Horizontal, Vertical Up, Vertical Down, Angular Up, Angular Down	-	Horizontal, Vertical Up, Vertical Down, Angular Up, Angular Down
Paint Finishes	Mill Finish	Hi Pro Polyester, Industrial Epoxy	Mill Finish	Hi Pro Polyester, Industrial Epoxy

* No stainless steel linkage. Five inch (127mm) wide mullion required on two panel wide due to bearings.

Size Limitations

W x H	Minimum Size	Maximum Size	
		Single Section	Multi - Section
Inches	6 x 6.5	60 x 96	120 x 96
mm	152 x 165	1524 x 2438	3048 x 2438

Advise air flow direction & counterbalance weight location when ordering

Counterbalance Weight Dimensions

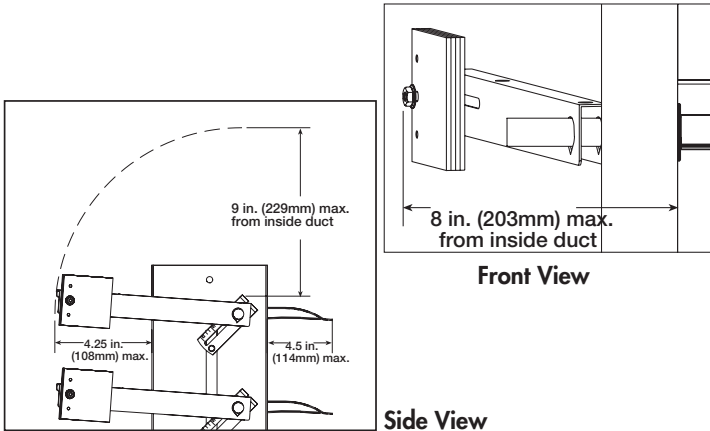

Pressure Limitations

The chart below shows conservative pressure limitations based on a maximum blade deflection of $w/360$.

Temperature Limitations

Blade seals: -40° to 250°F (-40° to 121°C)

For higher temperatures, consult factory.

Velocity Limitations

The chart below shows velocity limitations based on damper size.

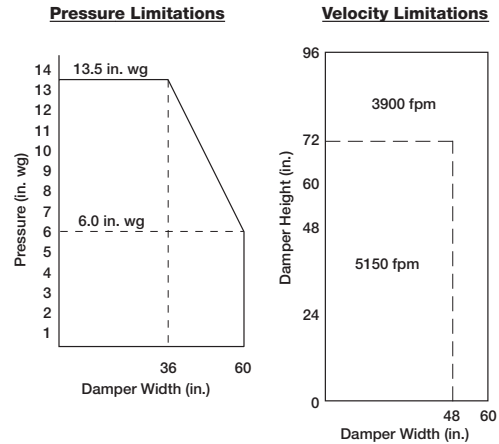

Performance Data

Pressure Drop Data

This pressure drop data was conducted in accordance with AMCA Standard 500-D using the three configurations shown. All data has been corrected to represent standard air at a density of $.075 \text{ lb/ft}^3$ (1.2 kg/m^3).

Actual pressure drop found in any HVAC system is a combination of many factors. This pressure drop information along with an analysis of other system influences should be used to estimate actual pressure losses for a damper installed in a given HVAC system.

AMCA Test Figures

Figure 5.3 illustrates a fully ducted damper. This configuration has the lowest pressure drop of the three test configurations because the entrance and exit losses are minimized by straight duct runs upstream and downstream of the damper.

Figure 5.2 illustrates a ducted damper exhausting air into an open area. This configuration has a lower pressure drop than Figure 5.5 because the entrance losses are minimized by a straight duct run upstream of the damper.

Figure 5.5 illustrates a plenum mounted damper. This configuration has the highest pressure drop because of the high entrance and exit losses due to the sudden changes of area in the system.

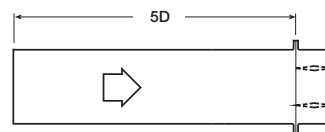
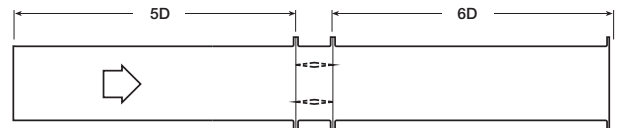

$$D = \sqrt{\frac{4(W)(H)}{3.14}}$$

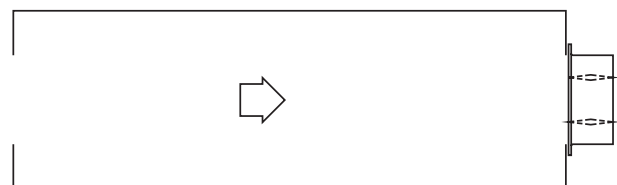

Performance Data

Pressure Drop

36 in. x 36 in. (914mm x 914mm) Damper

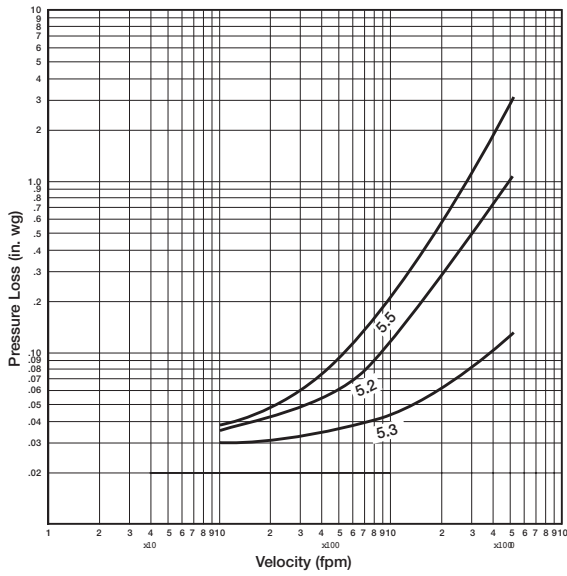

Leakage Data

Leakage testing was conducted in accordance with AMCA Standard 500-D and is expressed as CFM per sq. ft. of damper face area. All data has been corrected to represent standard air at a density of 0.075 lb/ft³ (1.2 kg/m³).

Leakage

36 in. x 36 in. (914mm x 914mm) Damper

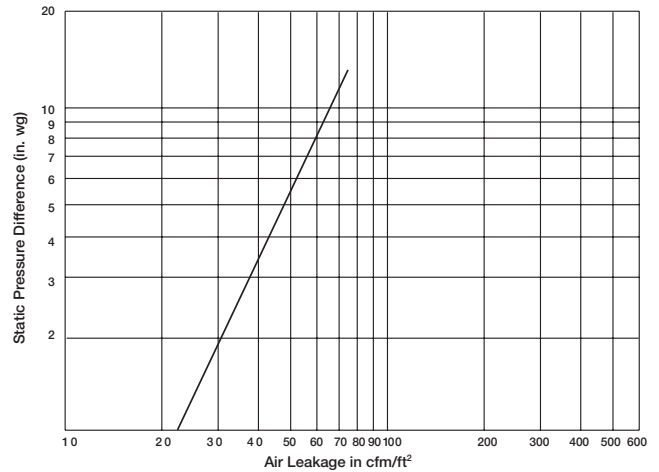

Mounting Holes

Bolt holes are available as an option. The standard pattern is 7/16 in. (11mm) diameter holes (M dimension) spaced 6 in. (152mm) on center (L dimension). Custom bolt hole patterns are available. Contact factory for the limitations.

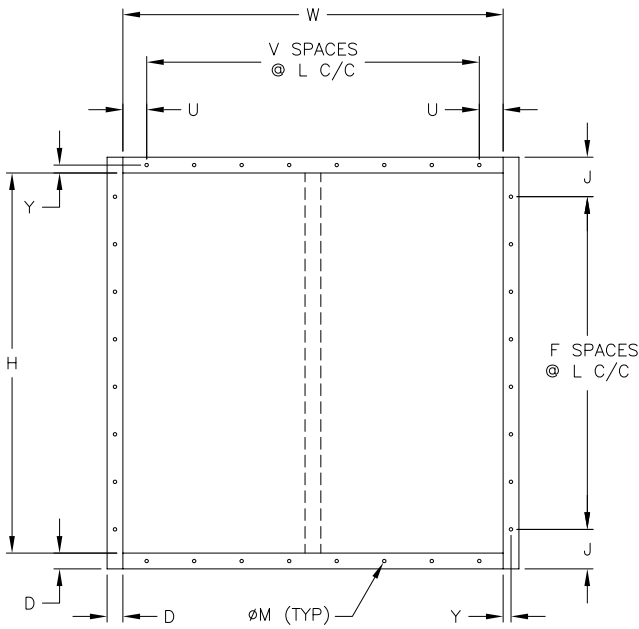

Standard Mounting Hole Pattern
Typical for single or double wide panel

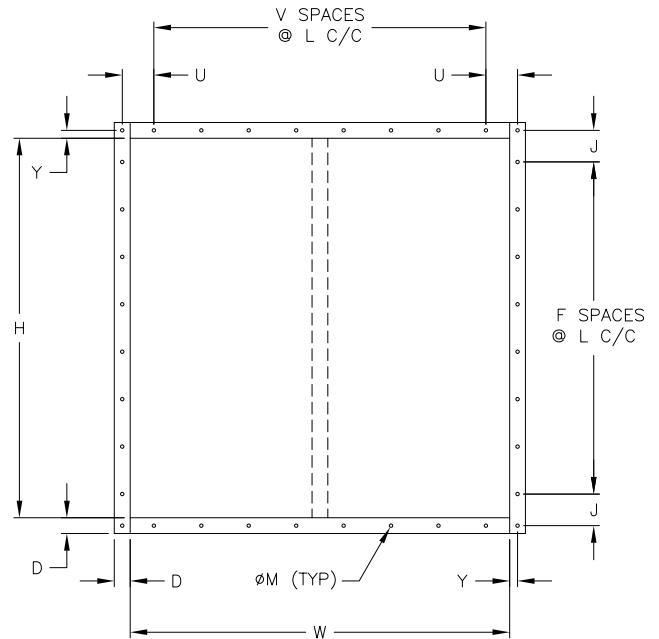

Standard Mounting Hole Pattern with Corner Holes
Typical for single or double wide panel

Multiple Section Assembly

Damper sizes larger than 60 in. x 96 in. (1524mm x 2438mm) and less than 120 in. x 96 in. (3048mm x 2438mm) will be supplied in one frame with two sets of blades separated by a mullion as shown below. Counterbalance weights supplied on right hand and left hand side. For sizes larger than 120 in. x 96 in. (3048mm x 2438mm), consult factory.

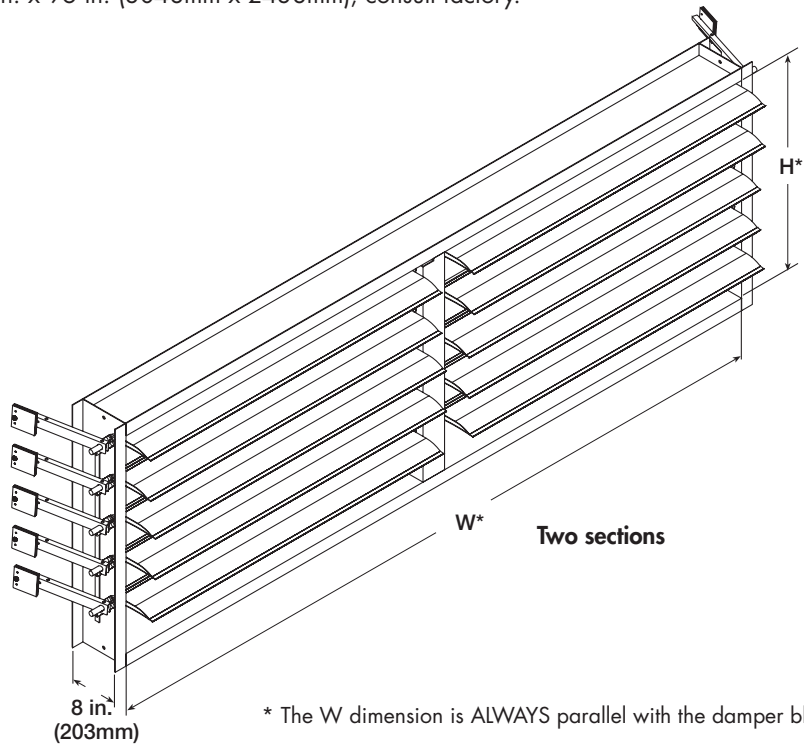

* The W dimension is ALWAYS parallel with the damper blade length.

Document Links

[Installation Instructions](#)



[Heavy Duty and Industrial Product Selection Guide](#)



[Heavy Duty/Industrial Damper Catalog](#)



[Warranty](#)



Copyright © 2023 Venco Products

HB-240, R5, March 2023

Venco Products reserves the right to make product changes without notice.