

## Application

Model HBR-050 is a light duty round industrial backdraft damper with a flanged style frame. It allows air to be drawn into a draft relief application or to prevent backflow in an HVAC or a process application.

## Ratings

### Velocity

Up to 3000 fpm (15.2 m/s)

### Temperature

Up to 250°F (121°C)

### Pressure

Up to 6 in. wg (1.5 kPa) - differential pressure

## Construction

	Standard	Optional
Frame Material	Galvanized steel	Painted, 304SS, or 316SS
Frame Type	Flanged channel	-
Blade Material	Galvanized steel	Painted, 304SS, 316SS
Blade Seals	None	-
Blade Type	Round	
Axle Bearing	Galvanized steel ball	-
Axle Material	Plated steel	316SS
Airflow	-	Vertical up, Vertical down
Paint Finishes	Mill finish	Hi Pro Polyester
Mounting Holes	None	Parallel, Straddle

Diameter	Minimum Size	Maximum Size
Inches	7¼	24
mm	184	610

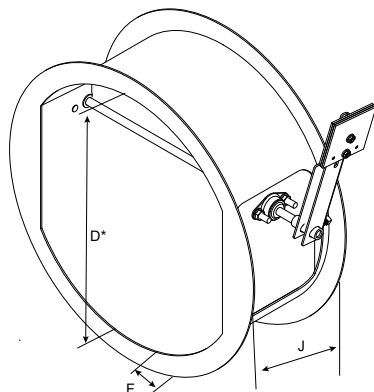

\*Actual inside dimension

Advise air flow direction & counterbalance weight location when ordering

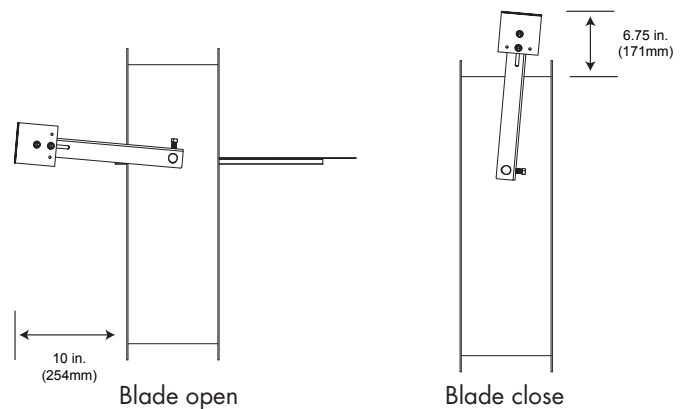

Diameter D Inches (mm)		Frame Depth J Inches (mm)	Frame & Flange Gauge (mm)	Flange Width F Inches (mm)	Square Axle Inches (mm)	Blade Thickness Gauge (mm)
Above	Through					
7¼ (184)	12 (305)	6 (152)	14 (2)	1.25 (32)	0.375 (9.5)	16 (1.5)
12 (305)	18 (457)	8 (203)	14 (2)	1.5 (32)	0.375 (9.5)	16 (1.5)
18 (457)	24 (610)	8 (203)	14 (2)	1.5 (32)	0.375 (9.5)	16* (1.5)

\* with reinforcements

## Performance Data

### AMCA Test Figure 5.3

Figure 5.3 illustrates a fully ducted damper. This configuration has low pressure drop because entrance and exit losses are minimized by straight duct runs upstream and downstream of the damper.

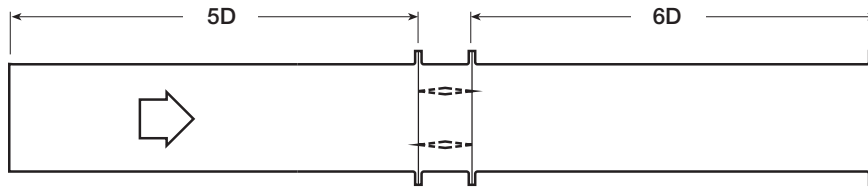

### Pressure Drop Data

This pressure drop data was conducted in accordance with AMCA Standard 500-D using Test Figure 5.3. All data has been corrected to represent standard air at a density of 0.075 lb./ft<sup>3</sup> (1.2 kg/m<sup>3</sup>).

Actual pressure drop found in any HVAC system is a combination of many factors. This pressure drop information along with an analysis of other system influences should be used to estimate actual pressure losses for a damper installed in a given HVAC system.

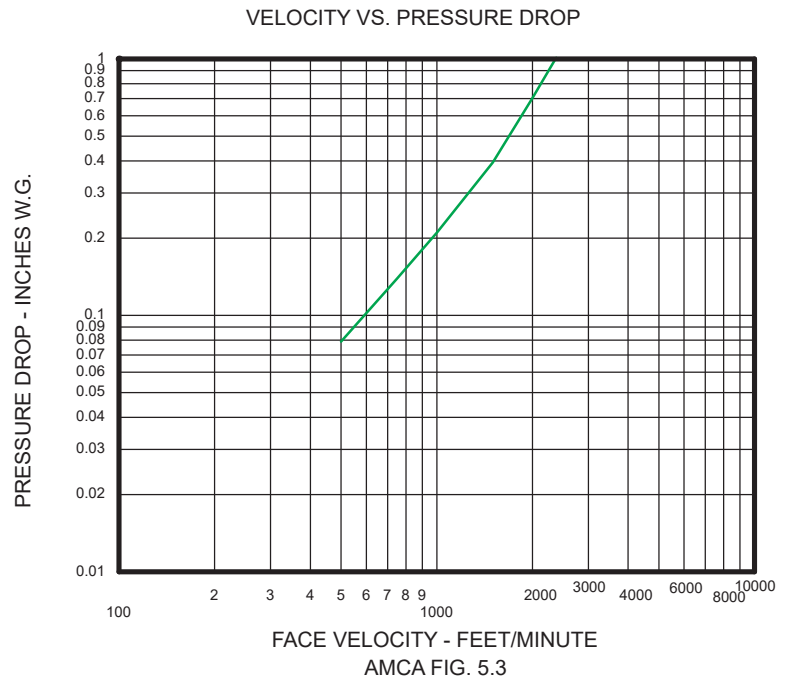

### Leakage Data

Damper leakage (with blade fully closed) varies based on the type of blade stops and low leakage seals applied. Model HBR-050 is available with no seals. Leakage testing was conducted in accordance with AMCA Standard 500-D and is expressed as cfm/ft<sup>2</sup> of damper face area. All data has been corrected to represent standard air at a density of 0.075 lb./ft<sup>3</sup> (1.2 kg/m<sup>3</sup>).

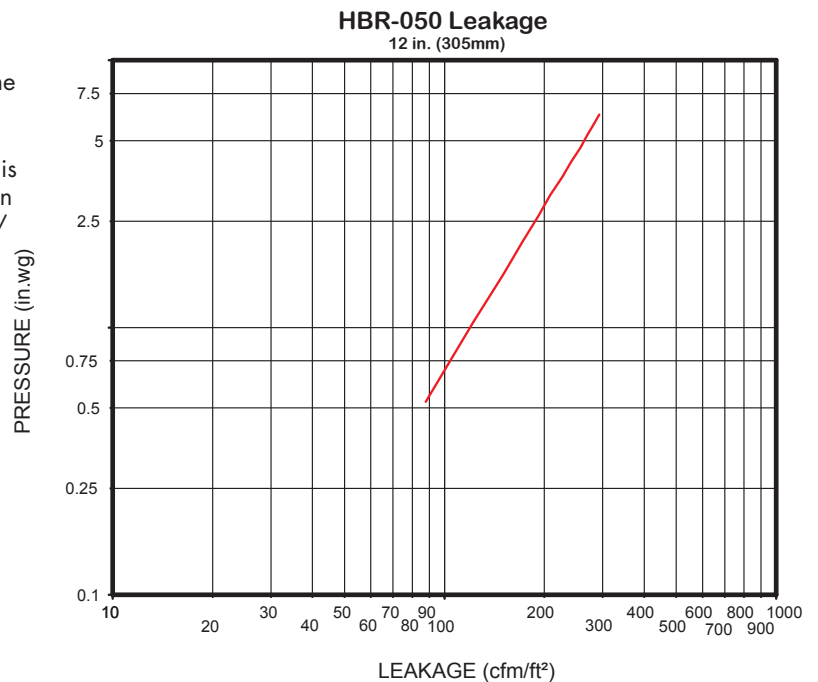

# Mounting Holes

The recommended bolt hole pattern is shown in the table below. Customer must specify bolt holes that are parallel to the axle centerline or that straddle the axle centerline as shown in the diagrams below. The factory can also provide bolt hole sizes and patterns other than those shown.

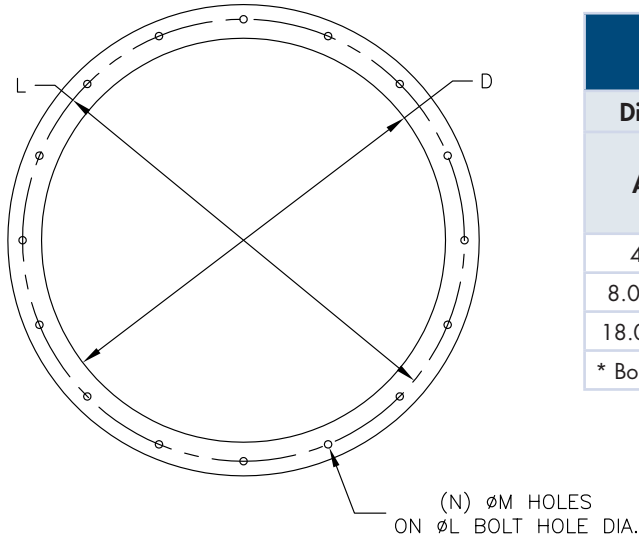

Recommended Bolt Hole Pattern (Bolt Holes Parallel to Axle Centerline)					
Diameter Inches (mm)		Number of Holes	Mounting Hole Diameter in. (mm) N	Bolt Circle Diameter L	Degrees Between Holes
Above	Through				
4 (102)	8 (203)	4	3/8 (9.5)	*	90
8.001 (203)	18 (457)	8	7/16 (11)	*	45
18.001 (457)	24 (610)	12	7/16 (11)	*	30

\* Bolt Circle Diameter = Damper Diameter + Flange Height + 1/4 in. (6mm)

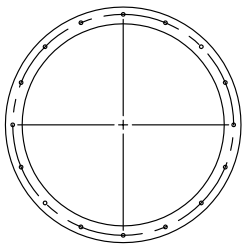

On Centerline

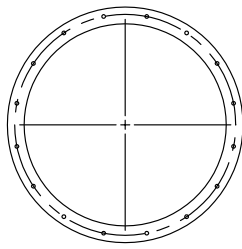

Straddle Centerline

# Document Links

[Installation Instructions](#)



[Heavy Duty/Industrial Damper Catalog](#)



[Heavy Duty and Industrial Product Selection Guide](#)



[Heavy Duty and Industrial Product Selection Guide](#)



[Warranty](#)



Copyright © 2023 Venco Products

HBR-050, R4, March 2023

Venco Products reserves the right to make product changes without notice.