

Application

Model HBR-150 is a heavy duty round industrial backdraft damper with a flanged style frame. It allows air to be drawn into a draft relief application or to prevent backflow in an HVAC or a process application.

Ratings

Velocity

Up to 4000 fpm (20.3 m/s)

Temperature

Up to 250°F (121°C)

Pressure

Up to 6 in. wg (1.5 kPa) - differential pressure

Construction

	Standard	Optional
Frame Material	Painted	304SS or 316SS
Frame Type	Flanged channel	-
Blade Material	Painted	304SS or 316SS
Blade Seals	None	EPDM or Silicone
Blade Stop	Pin	Roller bar
Blade Type	Round	
Axle Bearing	Stainless steel sleeve	External bronze sleeve, External relubricable ball
Axle Material	Plated steel	303SS or 316SS
Airflow	Horizontal	Vertical up, Vertical down
Paint Finishes	Hi Pro Polyester	Mill finish (SS only)
Mounting Holes	None	On centerline, Straddle centerline

Diameter	Minimum Size	Maximum Size
Inches	6	36
mm	154	914

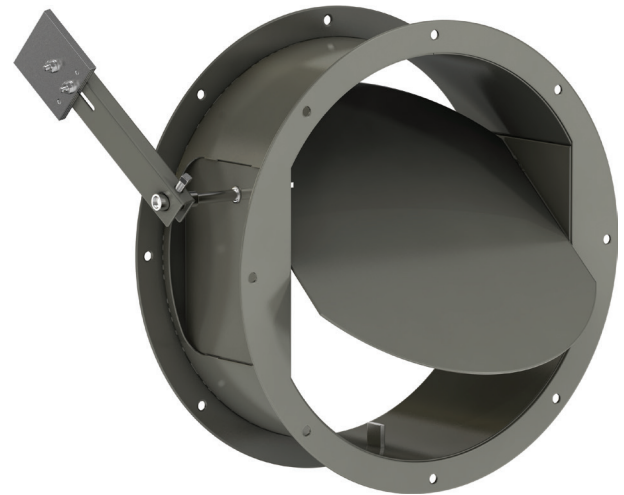
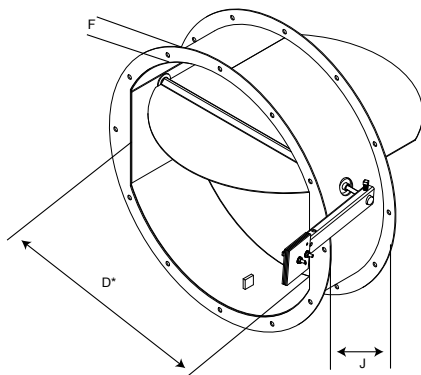

*Actual inside dimension

Advise air flow direction & counterbalance weight location when ordering

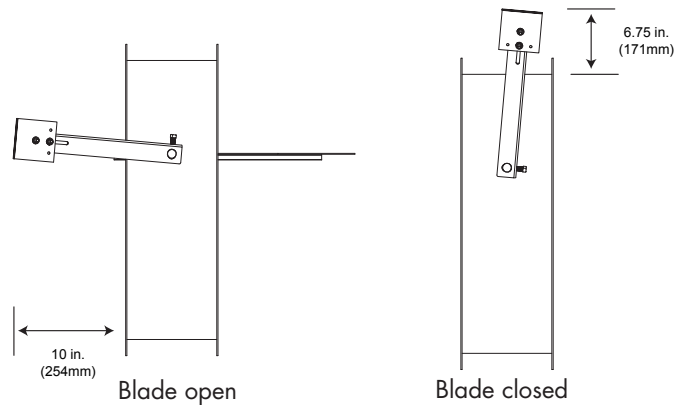

Diameter D Inches (mm)		Frame Depth J Inches (mm)	Frame & Flange Gauge (mm)	Flange Width F Inches (mm)	Axle Diameter Inches (mm)	Blade Thickness Gauge (mm)
Above	Through					
6 (154)	12 (305)	6 (152)	12 (2.7)	1.25 (32)	0.5 (13)	12 (2.7)
12 (305)	20 (508)	8 (203)	12 (2.7)	1.5 (32)	0.75 (19)	10* (3.5)
20 (508)	24 (610)	8 (203)	12 (2.7)	1.5 (32)	0.75 (19)	10* (3.5)
24 (610)	36 (914)	8 (203)	10 (3.5)	2 (51)	0.75 (19)	10* (3.5)

* with reinforcements

Performance Data

AMCA Test Figure 5.3

Figure 5.3 illustrates a fully ducted damper. This configuration has low pressure drop because entrance and exit losses are minimized by straight duct runs upstream and downstream of the damper.

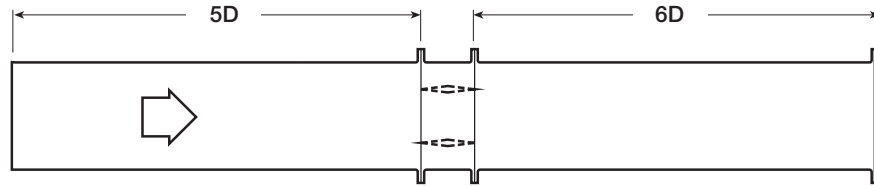

Pressure Drop Data

This pressure drop data was conducted in accordance with AMCA Standard 500-D using Test Figure 5.3. All data has been corrected to represent standard air at a density of 0.075 lb./ft³ (1.2 kg/m³).

Actual pressure drop found in any HVAC system is a combination of many factors. This pressure drop information along with an analysis of other system influences should be used to estimate actual pressure losses for a damper installed in a given HVAC system.

HBR-150 Pressure Drop

24 in. (610 mm)

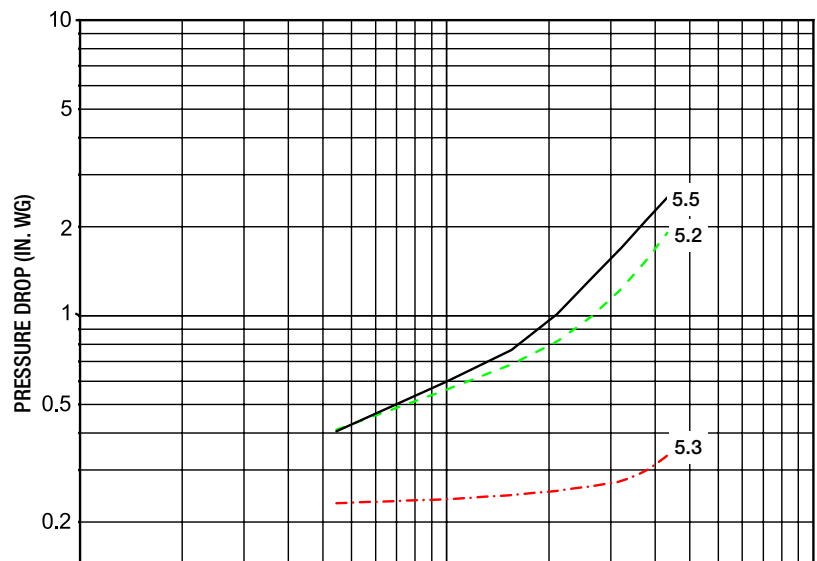

HBR-150 Leakage

Leakage Data

Damper leakage (with blade fully closed) varies based on the type of blade stops and low leakage seals applied. Model HBR-150 is available with no seals. Leakage testing was conducted in accordance with AMCA Standard 500-D and is expressed as cfm/ft² of damper face area. All data has been corrected to represent standard air at a density of 0.075 lb./ft³ (1.2 kg/m³).

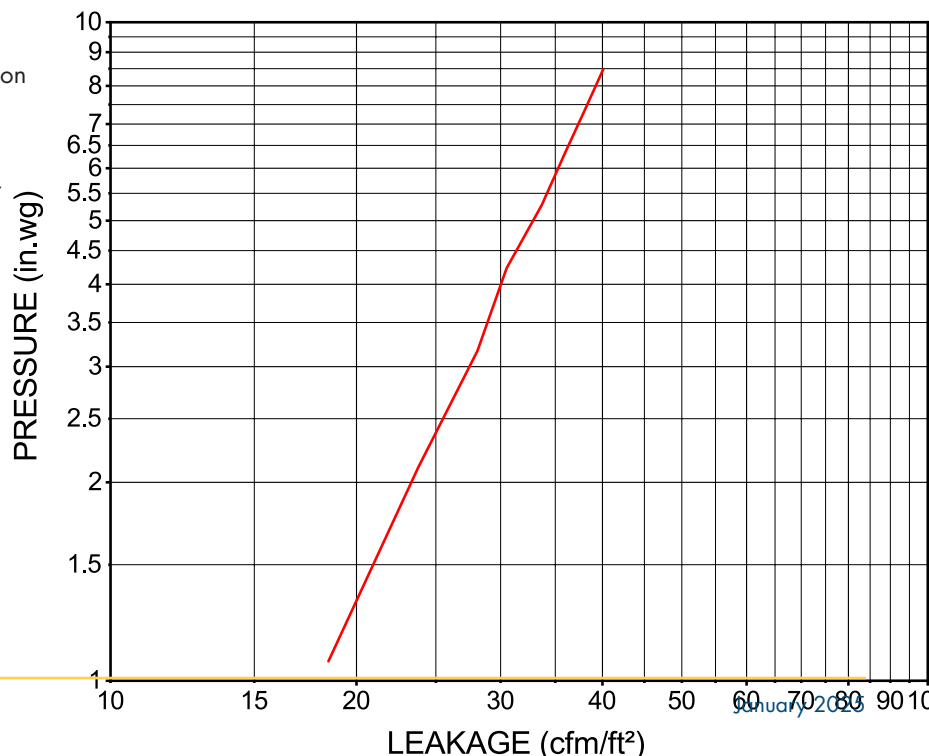

Mounting Holes

The recommended bolt hole pattern is shown in the table below. Customer must specify bolt holes that are parallel to the axle centerline or that straddle the axle centerline as shown in the diagrams below. The factory can also provide bolt hole sizes and patterns other than those shown.

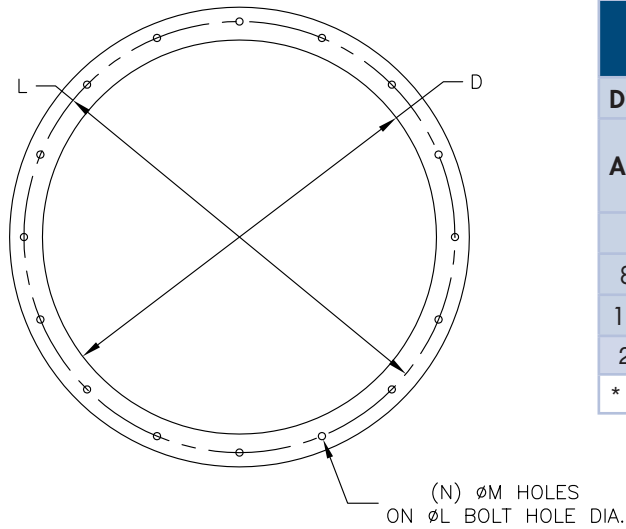

Recommended Bolt Hole Pattern (Bolt Holes Parallel to Axle Centerline)					
Diameter Inches (mm)		Number of Holes	Mounting Hole Diameter in. (mm) N	Bolt Circle Diameter L	Degrees Between Holes
Above	Through				
4 (102)	8 (203)	4	$\frac{3}{8}$ (9.5)	*	90
8.001 (203)	18 (457)	8	$\frac{7}{16}$ (11)	*	45
18.001 (457)	24 (610)	12	$\frac{7}{16}$ (11)	*	30
24.001 (610)	36 (914)	16	$\frac{7}{16}$ (11)	*	22 ½

* Bolt Circle Diameter = Damper Diameter + Flange Height + ¼ in. (6mm)

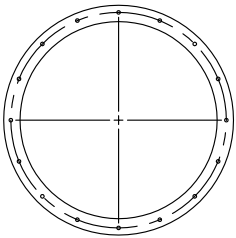

On Centerline

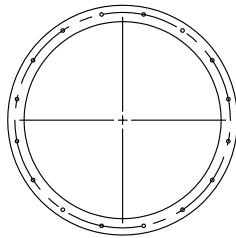

Straddle Centerline

Document Links



[INSTALLATION](#)



[CATALOG](#)



[HD PRODUCT GUIDE](#)



[SELECTION GUIDE](#)



[WARRANTY](#)



Copyright © 2025 Venco Products
HBR-150, R5, January 2025

Venco Products reserves the right to make product changes without notice.