



# HBS-430 & HBS-431 Heavy Blast Suppressor

## Application and Design

Models HBS-430 and HBS-431 are heavy duty double flanged channel frame style dampers with double thickness fabricated airfoil blades. They are designed to protect against rapid pressure changes due to an explosion. Designed to pressures as high as 15 psi covers many applications in Unified Facilities Criteria (UFC) and General Services Administration (GSA) codes and standards, including Charge Weight I at 82 ft.

**HBS-430**

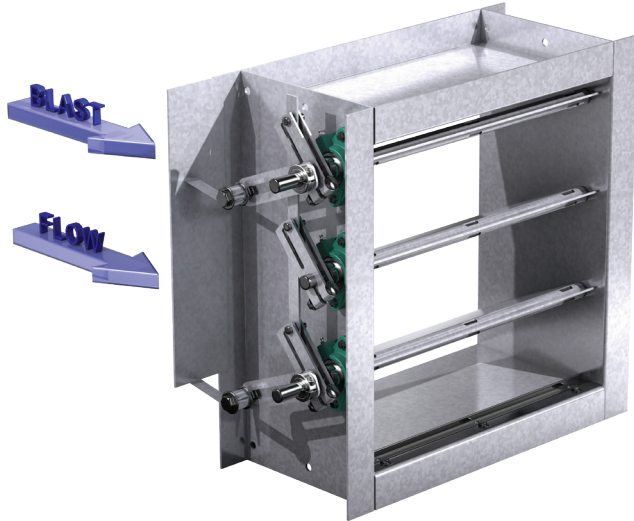

**HBS-431**

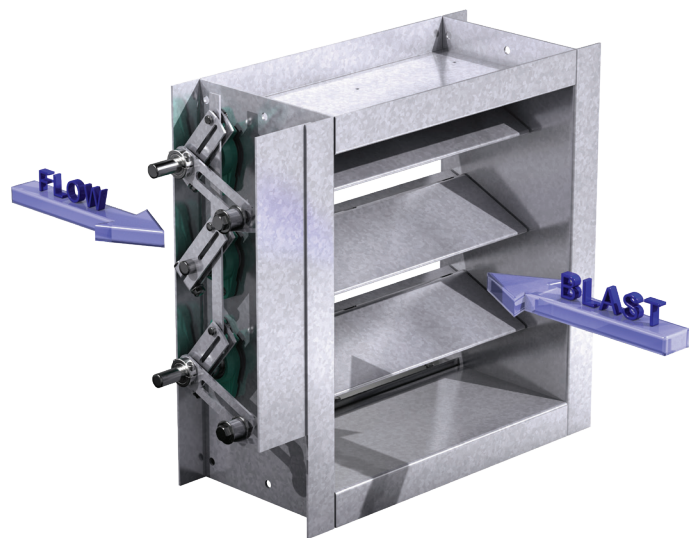

\* Actual Inside Dimension.

\*\* The W dimension is ALWAYS parallel with the damper blade length.

**Note:** Spring Location is determined from the perspective of viewing the damper in the blast direction, i.e. the blast hitting you in the back of the head.

## Ratings

**Pressure:** 1.5 - 15 psi (42 - 415 in wg)  
(20 - 103 kPa) blast load

**Velocity:** 500 to 4000 fpm (2.5 to 20.3 m/s)

**Temperature:** Minimum: -40°F (-40°C)  
Maximum: 250°F (121°C)

\* For higher blasts or larger opening sizes, consult factory.

Code	Blast Loading
GSA- Level C	4 psi @ 28 psi-msec
UFC 4-010-01 (charge weight I at 148 ft)	4.76 psi @ 41.1 psi-msec
UFC 4-010-01 (charge weight II at 82 ft)	5.77 psi @ 29.69 psi-msec
GSA-Level D	10 psi @ 89 psi-msec
UFC 4-010-01 (charge weight I @ 82 ft)	12.6 psi @ 77.8 psi-msec

1. Charge weight I = large mass explosion as would be found in a vehicle bomb - specific explosive weights are for US Government "For official use only" clearance personnel.
2. Charge weight II = medium size mass explosions as would be found in a briefcase or backpack bomb - specific weights are for US Government "For official use only" clearance personnel.

## Size Limitations

Size Limitations			
W x H	Minimum Size	Maximum Size	Maximum Blast Pressure
		Single Section	
Inches	6 x 6	36 x 48	15 psi
mm	152 x 152	914 x 1219	103 kPa

## Options Available:

- Bolt holes in flanges

Construction	Standard	Optional
Frame Material	Galvanized steel	304SS, 316SS, Carbon Steel
Frame Material Thickness	10 ga. (3.5mm)	-
Frame Type	Flanged channel	-
Frame Depth	10 in. (254mm)	-
Blade Material	Galvanized steel	304SS, 316SS, Galvaneal
Blade Type	Airfoil	-
Blade Thickness	14 ga. min. (2mm) - blast less than or equal to 10 psi (277 in. wg [69kPa]); 12 ga. - blast greater than 10 psi (277 in. wg [69kPa])	
Axle Diameter	1 in. (25mm)	-
Axle Material	Plated steel	303SS, 316SS
Axle Bearings	External ball	-
Blade Seal	None	EPDM, Silicone
Linkage Material	Plated steel	304SS, 316SS
Flange Width	2 in. (51mm)	-
Springs	301SS	-
Spring Location	Right	Left
Finish	None	Hi Pro Polyester, Epoxy, Industrial Epoxy
Air Flow	Horizontal	Vertical Up or Vertical Down
Mounting Holes	None	Standard, Standard w/Corner Holes

## Pressure Drop Data

This pressure drop data was conducted in accordance with AMCA Standard 500 using the three configurations shown. All data has been corrected to represent standard air at a density of 0.075 lb/ft<sup>3</sup> (1.2 kg/m<sup>3</sup>).

Actual pressure drop found in any HVAC system is a combination of many factors. This pressure drop information along with an analysis of other system influences should be used to estimate actual pressure losses for a damper installed in a given HVAC system.

## AMCA Test Figures

**Figure 5.3** Illustrates a fully ducted damper. This configuration has the lowest pressure drop of the three test configurations because entrance and exit losses are minimized by straight duct runs upstream and downstream of the damper.

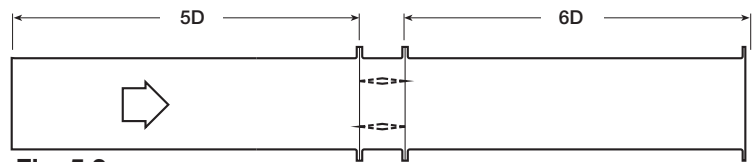

**Fig. 5.3**

**Figure 5.2** Illustrates a ducted damper exhausting air into an open area. This configuration has a lower pressure drop than Figure 5.5 because the entrance losses are minimized by a straight duct run upstream of the damper.

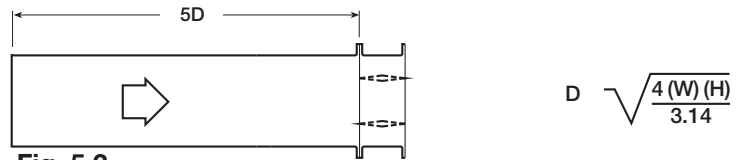

**Fig. 5.2**

**Figure 5.5** Illustrates a plenum mounted damper. This configuration has the highest pressure drop because of the high entrance and exit losses due to the sudden changes of area in the system.

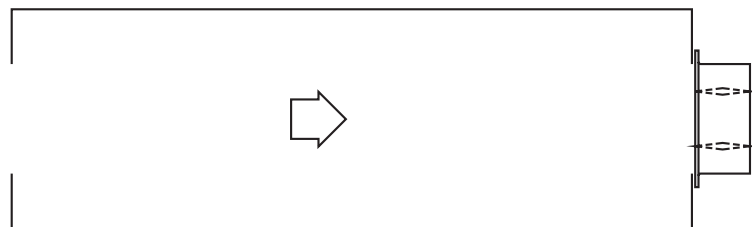

**Fig. 5.5**

## AMCA Test Figures

## Leakage Data

Leakage testing was conducted in accordance with AMCA Standard 500 and is expressed as cfm/ft<sup>2</sup> of damper face area. All data has been corrected to represent standard air at a density of 0.075 lb/ft<sup>3</sup> (1.2 kg/m<sup>3</sup>).

## Pressure Drop

36 in. x 36 in. Damper (914mm x 914mm)

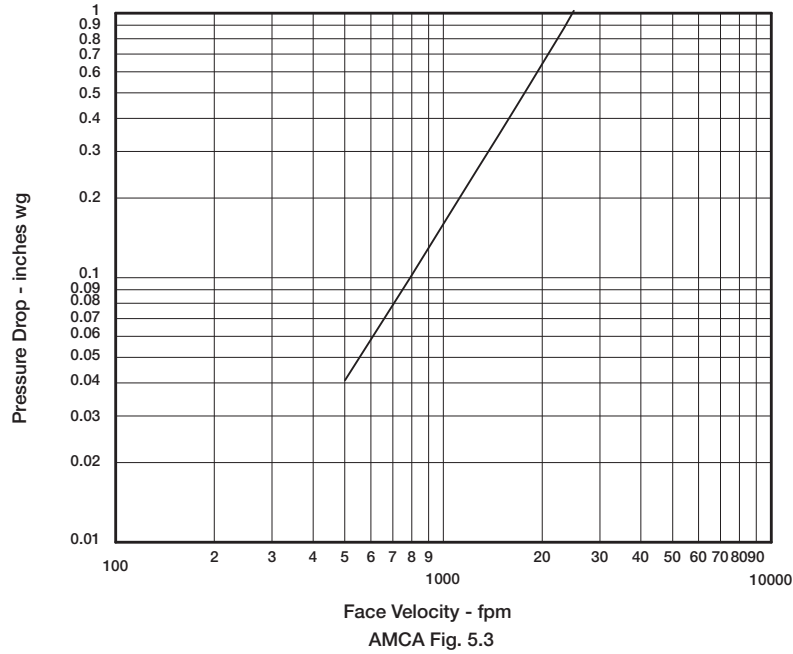

## Bolt Hole Limitations

Bolt holes are available as an option. The standard pattern is  $\frac{7}{16}$  in. (11mm) diameter holes (M dimension) spaced 6 in. (152mm) on center (L dimension). Custom bolt hole patterns are available. Contact factory for the limitations.

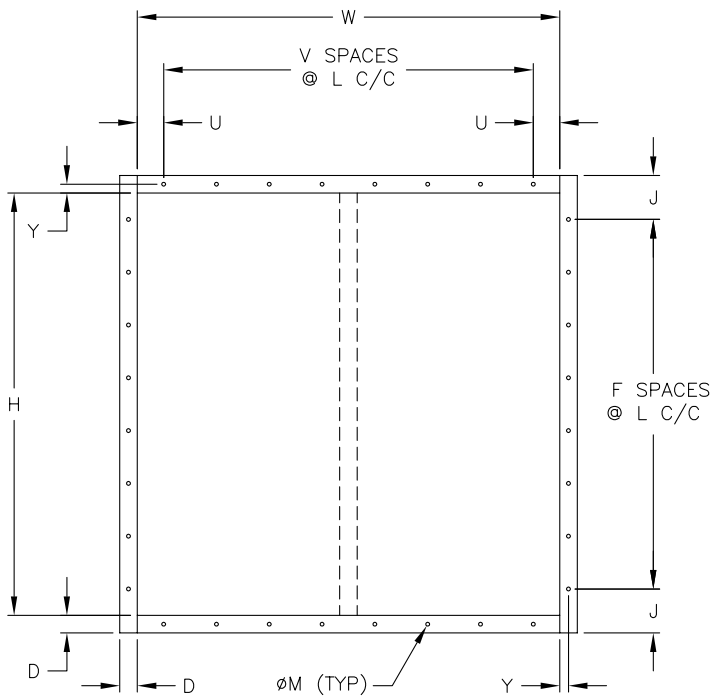

Standard Mounting Hole Pattern  
Typical for single or double wide panel

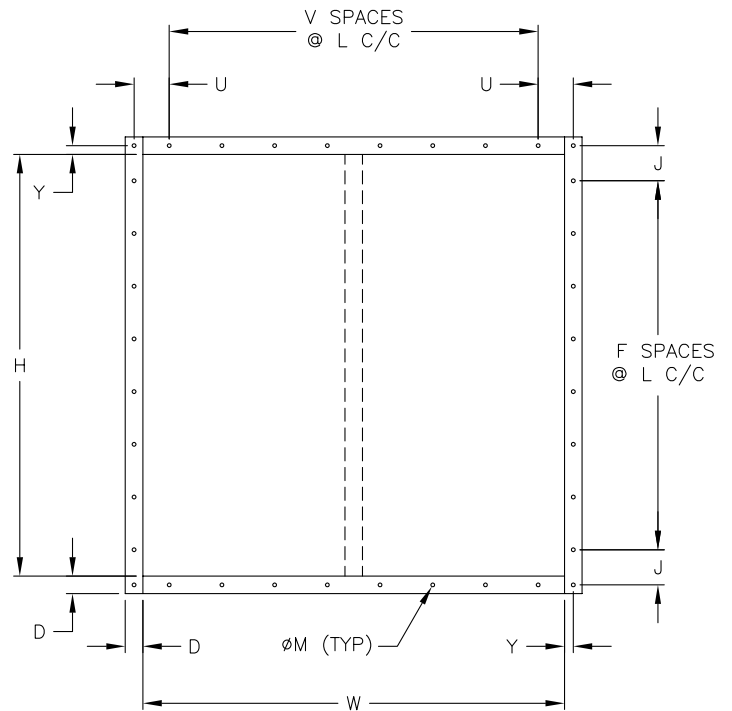

Standard Mounting Hole Pattern with Corner Holes  
Typical for single or double wide panel

## Model HBS-430 and HBS-431 Difference

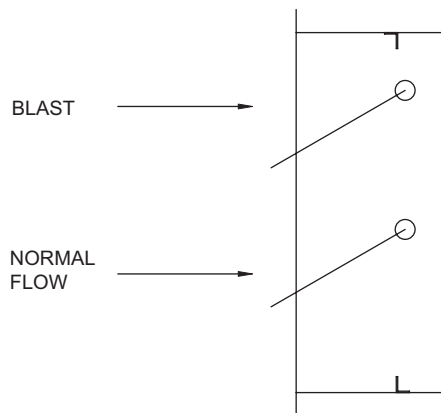

**Model HBS-430**

This model closes in the same direction as normal flow.

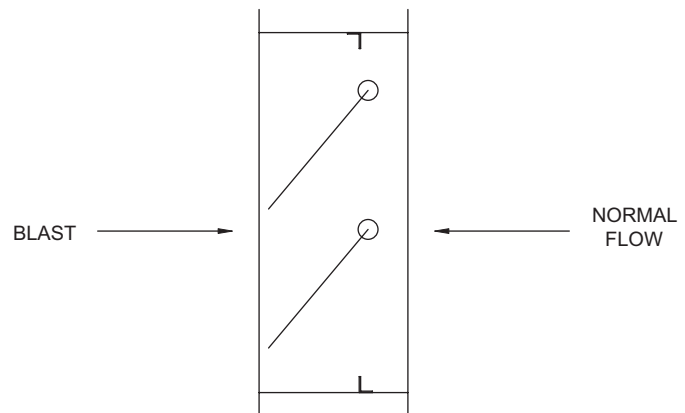

**Model HBS-431**

This model closes in the opposite direction as normal flow.

**Note:** Spring Location is from the perspective of viewing the damper in the blast direction.

## Specifications for HBS-430

Industrial grade blast dampers meeting the following specifications shall be furnished and installed where shown on plans and/or as described in schedules.

Dampers shall consist of: 10 ga. (3.5mm) Galvanized steel channel frame sized for the blast pressures noted with 10 in. (254mm) minimum depth and 2 in. (51mm) flanges; airfoil shaped, 12 ga. (2.7mm) galvanized steel double skin construction blades; 1 in. (25mm) dia. plated steel axles turning in externally mounted ball bearings; and external (out of the airstream)  $\frac{3}{8}$  in. (9.5mm) clevis pin linkage with adjustable constant force springs to hold blades open under normal flow conditions.

Damper manufacturer's printed application and performance data including pressure, velocity and temperature limitations shall be submitted for approval showing damper suitable for pressures to 15 psi (415 in. wg blast load) (103 kPa), velocities to 4000 fpm (20.3 m/s) and temperatures to 250°F (121°C). Testing and ratings to be in accordance with AMCA Standard 500, UFC4-010-01 (weight I @ 82 ft.), UFC4-010-01 (weight I @ 148 ft.) UFC4-010-01 (weight II), GSA - Level C and GSA - Level D.

Basis of design is model HBS-430.

## Specifications for HBS-431

Industrial grade blast dampers meeting the following specifications shall be furnished and installed where shown on plans and/or as described in schedules.

Dampers shall consist of: 10 ga. (3.5mm) Galvanized steel channel frame sized for the blast pressures noted with 10 in. (254mm) minimum depth and 2 in. (51mm) flanges; airfoil shaped, 12 ga. (2.7mm) galvanized steel double skin construction blades; 1 in. (25mm) dia. plated steel axles turning in externally mounted ball bearings; and external (out of the airstream)  $\frac{3}{8}$  in. (9.5mm) clevis pin linkage with adjustable constant force springs to hold blades open under normal flow conditions.

Damper manufacturer's printed application and performance data including pressure, velocity and temperature limitations shall be submitted for approval showing damper suitable for pressures to 15 psi (415 in. wg blast load) (103 kPa), velocities to 4000 fpm (20.3 m/s) and temperatures to 250°F (121°C). Testing and ratings to be in accordance with AMCA Standard 500, UFC4-010-01 (weight I @ 82 ft.), UFC4-010-01 (weight I @ 148 ft.) UFC4-010-01 (weight II), GSA - Level C and GSA - Level D.

Basis of design is model HBS-431.