

### Application

The HBT-221 is heavy duty rectangular damper designed for isolation and decontamination applications. The damper has bubble tight leakage performance per AMCA 500-D up to 10 in. wg (2.5 kPa). The damper frame is flanged for easy mounting and the blade seal is mechanically fastened to the blade.

### Ratings

<b>Leakage</b>	Bubble tight per AMCA 500-D
<b>Pressure*</b>	10 in. wg (2.5 kPa) - differential pressure
<b>Velocity*</b>	4000 fpm (20.3 m/s)
<b>Temperature*</b>	-40 to 250°F (-40 to 121°C)

### Construction

	Standard	Optional
<b>Frame Depth (C)</b>	See chart	-
<b>Frame Material</b>	Painted	304SS, 316SS
<b>Frame Type</b>	Flanged Channel	
<b>Frame Thickness</b>	12 ga. (2.7 mm)	-
<b>Flange Width (D)</b>	2 in. (51mm)	2 - 3 in. (51-76 mm)
<b>Blade Action</b>	Parallel	
<b>Blade Material</b>	Painted	304SS, 316SS
<b>Blade Seals</b>	Silicone	
<b>Blade Thickness</b>	12 ga. (2.7 mm)	
<b>Blade Type</b>	Rectangular butterfly	
<b>Linkage</b>	Plated steel	304SS, 316SS
<b>Axle Diameter**</b>	¾ in. (19 mm) or 1 in. (25 mm)	-
<b>Axle Bearing</b>	Outboard ball	
<b>Axle Material</b>	Plated steel	303SS, 316SS
<b>Axle Seals</b>	Double gland stuffing box	
<b>Paint Finishes</b>	Hi Pro Polyester	Industrial Epoxy, Mill finish (304SS or 316SS)
<b>Mounting Holes</b>	None	

\* with 12 ga. backing plate

\*\* Axle diameter is based on damper size, required torque, and actuator selection. Consult factory for specific information.

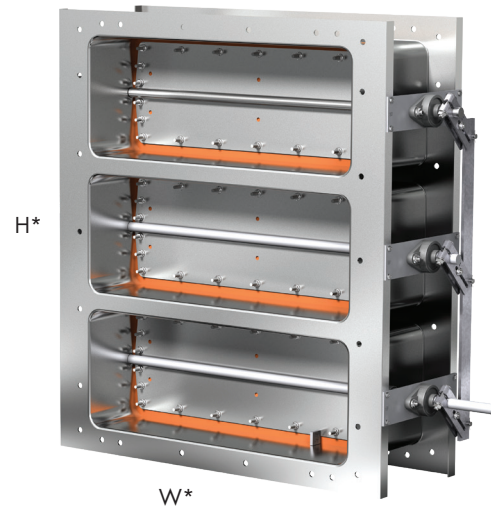

\* Actual inside dimension. The W dimension is ALWAYS parallel with the damper blade length.

Axes must always be in the horizontal plane.

### Frame Depth

Damper Height Inches (mm)		Number of Blades			
		1	2	3	4
Above	Through	Frame Depth - Inches (mm)			
5.99 (152)	8 (203)	8 (203)	-	-	-
8 (203)	10 (254)	10 (254)	-	-	-
10 (254)	12 (305)	12 (305)	-	-	-
12 (305)	14 (356)	14 (356)	-	-	-
14 (356)	17½ (445)	-	8 (203)	-	-
17½ (445)	21½ (546)	-	10 (254)	-	-
21½ (546)	25½ (648)	-	12 (305)	-	-
25½ (648)	27 (686)	-	-	8 (203)	-
27 (686)	33 (838)	-	-	10 (254)	-
33 (838)	39 (991)	-	-	12 (305)	-
39 (991)	44½ (1130)	-	-	-	10 (254)
44½ (1130)	52 (1321)	-	-	-	12 (305)

### Size Limitations

W x H	Minimum Size	Maximum Size	
		1 Blade	2 Blades
<b>Inches</b>	6 x 6	48 x 14	48 x 25½
<b>mm</b>	152 x 152	1219 x 356	1219 x 648
		3 Blades	4 Blades
<b>Inches</b>		48 x 39	48 x 52
<b>mm</b>		1219 x 991	1219 x 1321

## Performance Data

### Pressure Drop Data

This pressure drop data was conducted in accordance with AMCA Standard 500-D using the three configurations shown. All data has been corrected to represent standard air at a density of .075 lb/ft<sup>3</sup> (1.2 kg/m<sup>3</sup>).

Actual pressure drop found in any HVAC system is a combination of many factors. This pressure drop information along with an analysis of other system influences should be used to estimate actual pressure losses for a damper installed in a given HVAC system.

### AMCA Test Figures

**Figure 5.3** illustrates a fully ducted damper. This configuration has the lowest pressure drop of the three test configurations because the entrance and exit losses are minimized by straight duct runs upstream and downstream of the damper.

**Figure 5.2** illustrates a ducted damper exhausting air into an open area. This configuration has a lower pressure drop than Figure 5.5 because the entrance losses are minimized by a straight duct run upstream of the damper.

**Figure 5.5** illustrates a plenum mounted damper. This configuration has the highest pressure drop because of the high entrance and exit losses due to the sudden changes of area in the system.

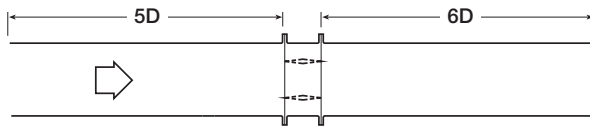

Fig. 5.3

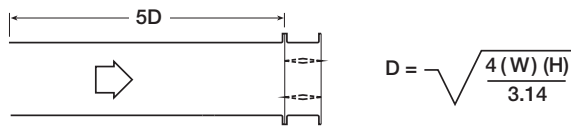

Fig. 5.2

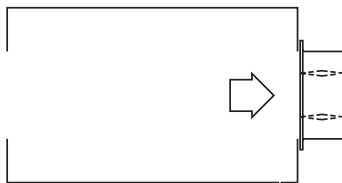
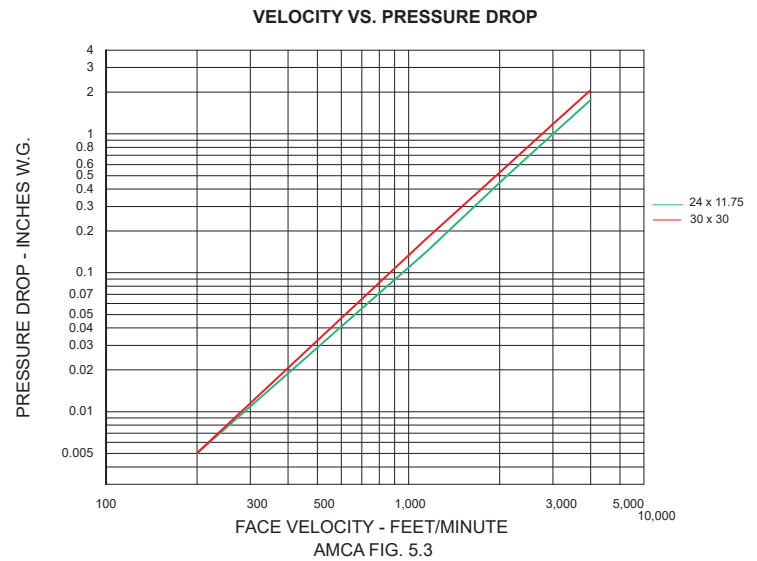

Fig. 5.5



### Leakage

Every HBT-221 is leakage tested at 10 in. wg (2.5 kPa) in accordance with AMCA 500-D before it leaves the factory. The HBT-221 does not ship unless it meets the requirements of the standard.

### Bearings and Axle Seal



#### Relubricable Ball Bearing

The relubricable ball bearing features a flanged cast iron housing that is bolted externally to the damper frame. Capable of high radial loads, this bearing can be applied in applications with high pressures or velocities. Seals protect the bearings' balls from the environment, making this bearing a better choice for application in dirty environments. External grease zerks allow for easy relubrication of the bearing.

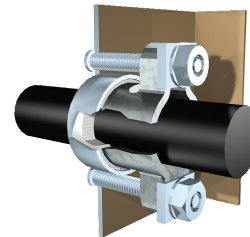

#### Double Gland Stuffing Box

The double gland stuffing box is recommended for clean air, contaminated air, and high temperatures.

## Mounting Holes

Bolt holes are available as an option. The standard pattern is  $\frac{7}{16}$  in. (11mm) diameter holes (M dimension) spaced 4 in. (102mm) on center (L dimension). Custom bolt hole patterns are available. Contact factory for the limitations.

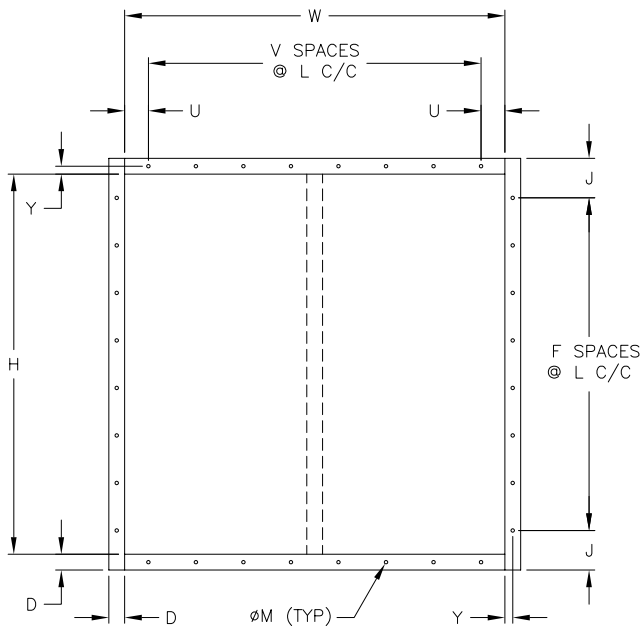

Standard Mounting Hole Pattern  
Typical for single or double wide panel

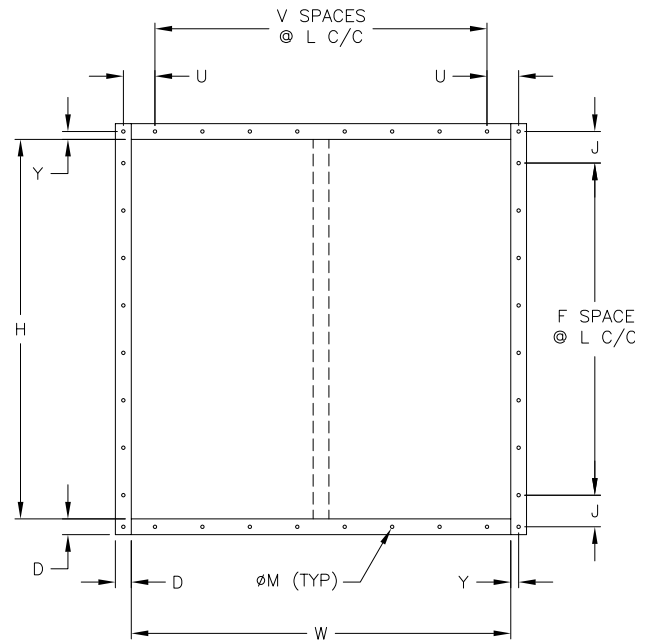

Standard Mounting Hole Pattern with Corner Holes  
Typical for single or double wide panel

## Document Links



[INSTALLATION](#)



[CATALOG](#)



[ISOLATION DAMPERS](#)



[SELECTION GUIDE](#)



[WARRANTY](#)



Copyright © 2024 Venco Products

HBT-221, R8, March 2024

Venco Products reserves the right to make product changes without notice.