

Application

The HBTR-151 is an isolation damper designed for isolation and decontamination applications. The damper has bubble tight leakage performance per AMCA 500-D up to 10 in. wg (2.5 kPa). The damper frame is flanged for easy mounting and the blade seal is mechanically fastened to the blade.

Ratings

Leakage

Bubble tight per AMCA 500-D

Pressure*

10 in. wg (2.5 kPa) - differential pressure

Velocity*

3900 fpm (19.8 m/s)

Temperature*

-40 to 250°F (-40 to 121°C)

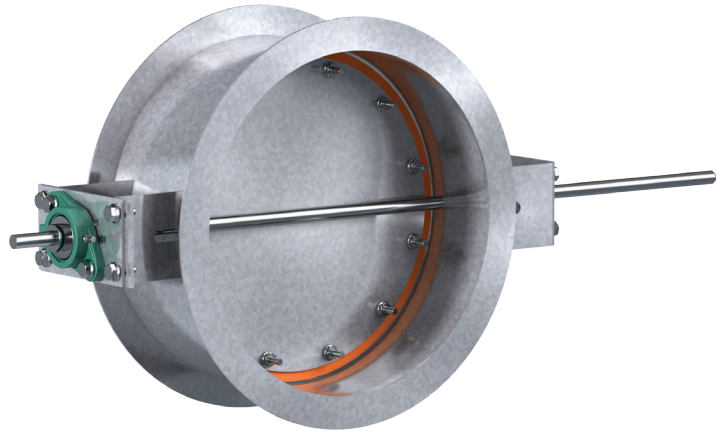

*Actual Inside Dimension

Construction

	Standard	Optional
Frame Depth (C)	See chart on page 2	
Frame Material	Painted	304SS, 316SS
Frame Type	Flanged Channel	
Frame Thickness	See chart on page 2	
Flange Width (D)	See chart on page 2	
Blade Material	Painted	304SS, 316SS
Blade Seals	Silicone rubber, mechanically fastened	
Blade Thickness	see chart on page 2	
Blade Type	Round butterfly	
Axle Diameter	see chart on page 2	
Bearings	Relubricable ball, outboard mounting	
Axle Material	Plated steel	303SS, 316SS
Axle Seals	Double gland stuffing box	
Paint Finishes	Hi Pro Polyester	Industrial Epoxy, Mill finish (304SS or 316SS)
Mounting Holes	None	Standard

Size Limitations

W x H	Minimum Size	Maximum Size
Inches	4	36
mm	102	914

Options:

- Mounting holes in flanges
- Actuators
- Limit switches
- Special construction

Dimensions

Diameter (D) Inches (mm)		Frame Depth J Inches (mm)	Frame & Flange gauge (mm)	Flange Width F Inches (mm)	Axle Diameter Inches (mm)	Blade Thickness gauge (mm)
Above	Through					
4 (102)	12 (305)	6 (152)	12 (2.7)	1.5 (38)	0.5 (13)	12 (2.7)
12 (305)	24 (610)	8 (203)	12 (2.7)	1.5 (38)	0.75 (19)	12 (2.7)
24 (610)	28 (711)	8 (203)	10 (3.5)	2 (51)	0.75 (19)	12 (2.7)
28 (711)	36 (914)	8 (203)	10 (3.5)	2 (51)	1 (25)	12 (2.7)

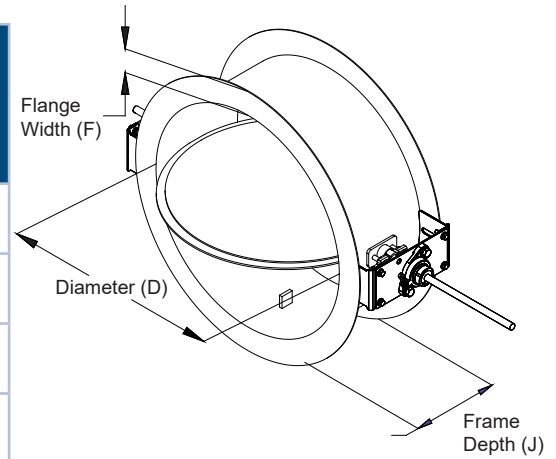

Mounting Holes

Standard - Does not include mounting holes

Optional - Bolt holes in both flanges

Greenheck recommended bolt hole pattern is shown in the table below. Customer must specify bolt holes that are parallel to the axle centerline (P) or that straddle the axle centerline (S) as shown in the diagrams below. Greenheck can also provide bolt hole sizes and patterns other than those shown below.

Greenheck Recommended Bolt Hole Pattern (Bolt Holes Parallel to Axle Centerline)					
Diameter Inches (mm)		Number of Holes	Mounting Hole Diameter in. (mm) N	Bolt Circle Diameter L	Degrees Between Holes
Above	Through				
4 (102)	8 (203)	4	$\frac{3}{8}$ (9.5)	*	90
8.001 (203)	18 (457)	8	$\frac{7}{16}$ (11)	*	45
18.001 (457)	24 (610)	12	$\frac{7}{16}$ (11)	*	30
24.001 (610)	36 (914)	16	$\frac{7}{16}$ (11)	*	22½

* Bolt Circle Diameter = Damper Diameter + Flange Height + ¼ in. (6mm)

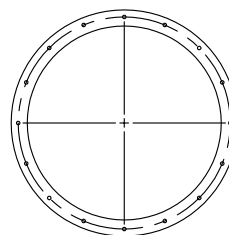
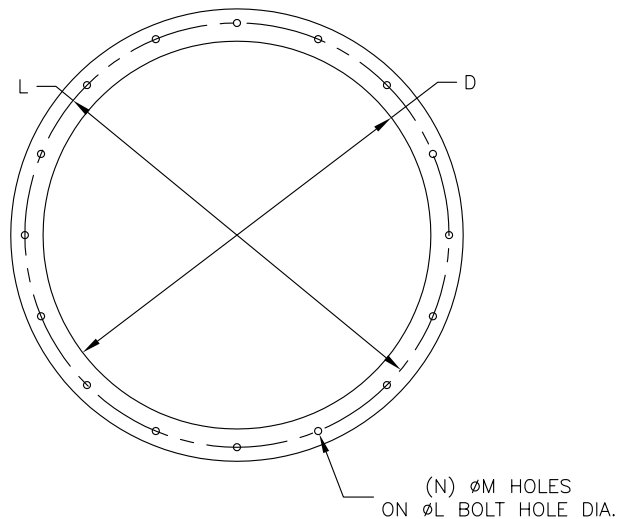

Parallel on Centerline

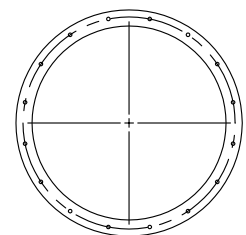

Straddle on Centerline

Performance Data

Pressure Drop Data

This pressure drop data was conducted in accordance with AMCA 500-D using Test Figure 5.3. All data has been corrected to represent standard air at a density of 0.075 lb/ft³ (1.2 kg/m³).

Actual pressure drop found in any HVAC system is a combination of many factors. This pressure drop information along with an analysis of other system influences should be used to estimate actual pressure losses for a damper installed in a given HVAC system.

AMCA Test Figure 5.3

Figure 5.3 illustrates a fully ducted damper. This configuration has low pressure drop because entrance and exit losses are minimized by straight duct runs upstream and downstream of the damper.

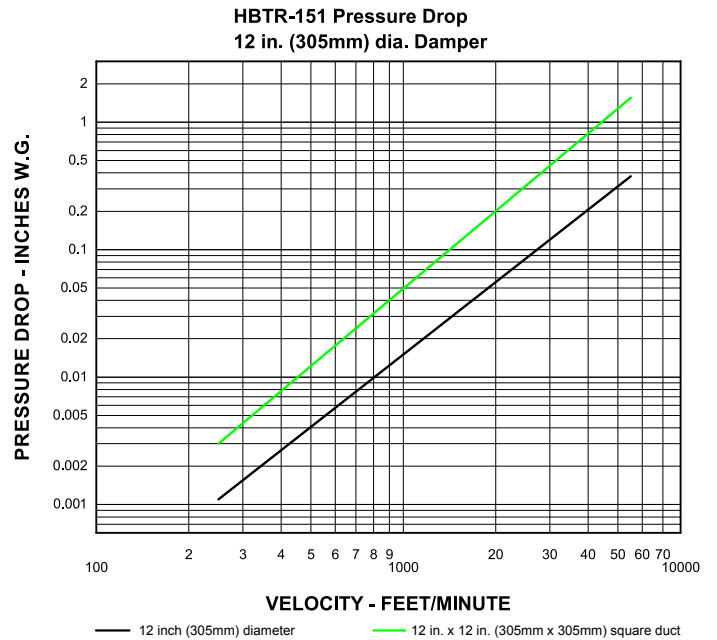
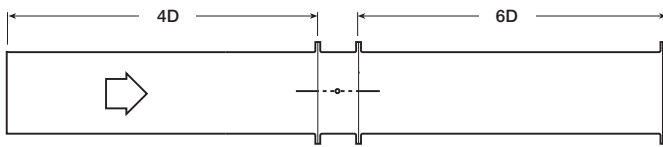

Leakage

Every HBTR-151 is leakage tested at 10 in. wg (2.5 KPa) in accordance with AMCA 500-D before it leaves the factory. Greenheck does not ship a HBTR-151 unless it meets the requirements of the standard.

Axle Seal Detail

The double gland axle seal is mounted externally for easy access and provides bubble tight performance.

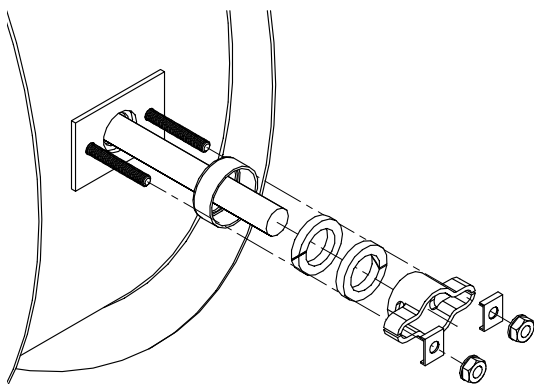

Bearing Detail

The ball bearings are mounted outboard for easy access. The bearing comes with a grease fitting, allowing for easy lubrication (axle seals included but not shown in bearing detail).

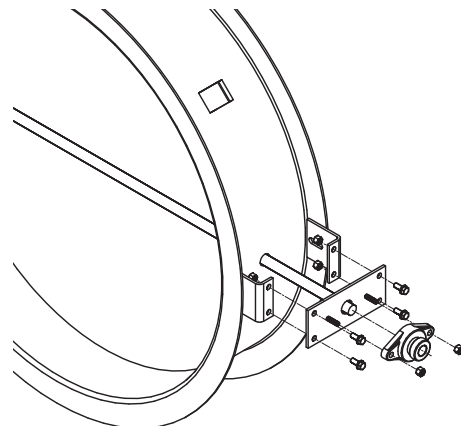

Document Links

[Installation Instructions](#)

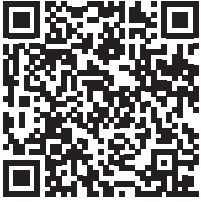

[Heavy Duty/Industrial Damper Catalog](#)



[Isolation Dampers](#)



[Heavy Duty/Industrial Damper Product Selection Guide](#)



[Warranty](#)

