

### Application

The HBTR-551 is an isolation damper designed for isolation and decontamination applications. The damper has bubble tight leakage performance per AMCA 500-D up to 30 in. wg (7.5 kPa). The damper frame is flanged for easy mounting and the blade seal is mechanically fastened to the blade.

### Ratings

<b>Leakage</b>
Bubble tight per AMCA 500-D
<b>Pressure*</b>
40 in. wg (10 kPa) - differential pressure
<b>Velocity*</b>
6500 fpm (33 m/s)
<b>Temperature*</b>
-40 to 250°F (-40 to 121°C)

### Construction

	Standard	Optional
<b>Frame Depth (C)</b>	See chart on page 2	
<b>Frame Material</b>	Painted	304SS, 316SS
<b>Frame Type</b>	Flanged Channel	
<b>Frame Thickness</b>	See chart on page 2	
<b>Flange Width (D)</b>	see chart on page 2	
<b>Blade Material</b>	Painted	304SS, 316SS
<b>Blade Seals</b>	Silicone rubber, field removable	
<b>Blade Thickness</b>	see chart on page 2	
<b>Blade Type</b>	Reinforced butterfly, field replaceable	
<b>Axle Diameter</b>	see chart on page 2	
<b>Bearings</b>	Relubricable ball, outboard mounting	
<b>Axle Material</b>	Plated steel	303SS, 316SS
<b>Axle Seals</b>	Double gland stuffing box	
<b>Paint Finishes</b>	Hi Pro Polyester	Industrial Epoxy, Mill finish (304SS or 316SS)
<b>Mounting Holes</b>	None	Standard

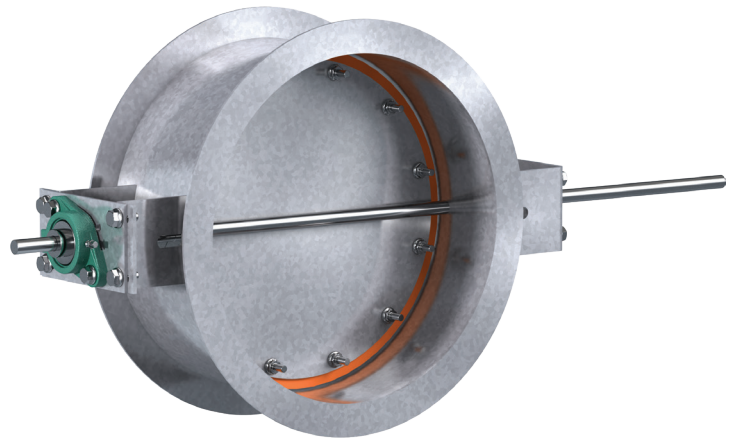

\*Actual Inside Dimension

### Size Limitations

W x H	Minimum Size	Maximum Size
<b>Inches</b>	6	48
<b>mm</b>	152	1219

### Options:

- Mounting holes in flanges
- Actuators
- Limit switches
- Special construction
- Temperatures greater than 250°F (121°C), consult factory.

## Dimensions

Diameter (D) Inches (mm)		Frame Depth J Inches (mm)	Frame & Flange gauge (mm)	Flange Width F Inches (mm)	Axle Diameter Inches (mm)	Blade Thickness gauge (mm)
Above	Through					
6 (152)	12 (305)	6 (152)	.188 (4.8)	1.5 (38)	0.75 (19)	.188 (4.8)
12 (305)	18 (457)	8 (203)	.188 (4.8)	1.5 (38)	0.75 (19)	.188 (4.8)
18 (457)	24 (610)	8 (203)	.188 (4.8)	1.5 (38)	1 (25)	.188 (4.8)
24 (610)	27 (686)	8 (203)	.188 (4.8)	2 (51)	1 (25)	.188 (4.8)
27 (686)	39 (991)	8 (203)	.188 (4.8)	2 (51)	1.25 (32)	.188 (4.8)
39 (991)	42 (1067)	8 (203)	.188 (4.8)	2 (51)	1.5 (38)	.188 (4.8)
42 (1067)	48 (1219)	8 (203)	.25 (6)	2 (51)	1.5 (38)	.188 (4.8)

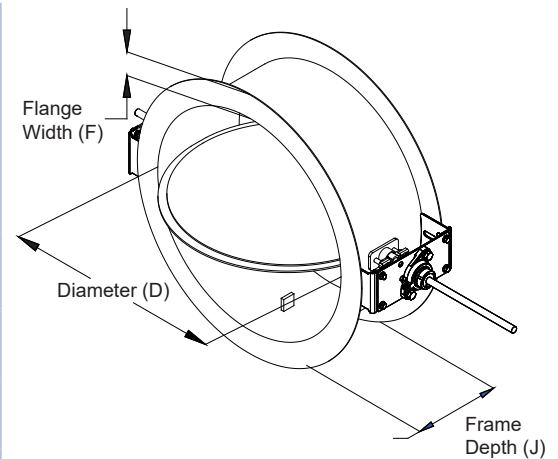

## Mounting Holes

Standard - Does not include mounting holes

Optional - Bolt holes in both flanges

Greenheck recommended bolt hole pattern is shown in the table below. Customer must specify bolt holes that are parallel to the axle centerline (P) or that straddle the axle centerline (S) as shown in the diagrams below. Greenheck can also provide bolt hole sizes and patterns other than those shown below.

Greenheck Recommended Bolt Hole Pattern (Bolt Holes Parallel to Axle Centerline)					
Diameter Inches (mm)		Number of Holes	Mounting Hole Diameter in. (mm) N	Bolt Circle Diameter L	Degrees Between Holes
Above	Through				
6 (152)	8 (203)	4	$\frac{3}{8}$ (9.5)	*	90
8.001 (203)	18 (457)	8	$\frac{7}{16}$ (11)	*	45
18.001 (457)	24 (610)	12	$\frac{7}{16}$ (11)	*	30
24.001 (610)	36 (914)	16	$\frac{7}{16}$ (11)	*	22½
36.001 (914)	48 (1219)	24	$\frac{7}{16}$ (11)	*	15

\* Bolt Circle Diameter = Damper Diameter + Flange Height + ¼ in. (6mm)

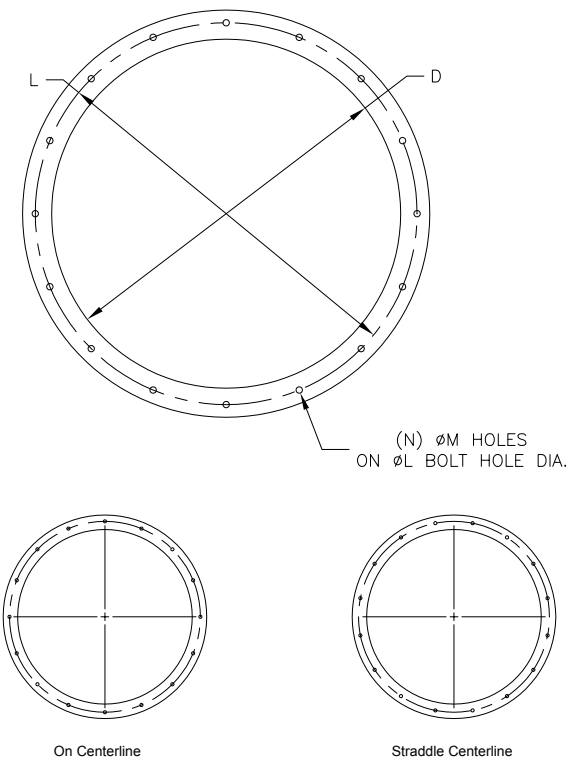

## Performance Data

### Pressure Drop Data

This pressure drop data was conducted in accordance with AMCA 500-D using Test Figure 5.3. All data has been corrected to represent standard air at a density of 0.075 lb/ft<sup>3</sup> (1.2 kg/m<sup>3</sup>).

Actual pressure drop found in any HVAC system is a combination of many factors. This pressure drop information along with an analysis of other system influences should be used to estimate actual pressure losses for a damper installed in a given HVAC system.

### AMCA Test Figure 5.3

Figure 5.3 illustrates a fully ducted damper. This configuration has low pressure drop because entrance and exit losses are minimized by straight duct runs upstream and downstream of the damper.

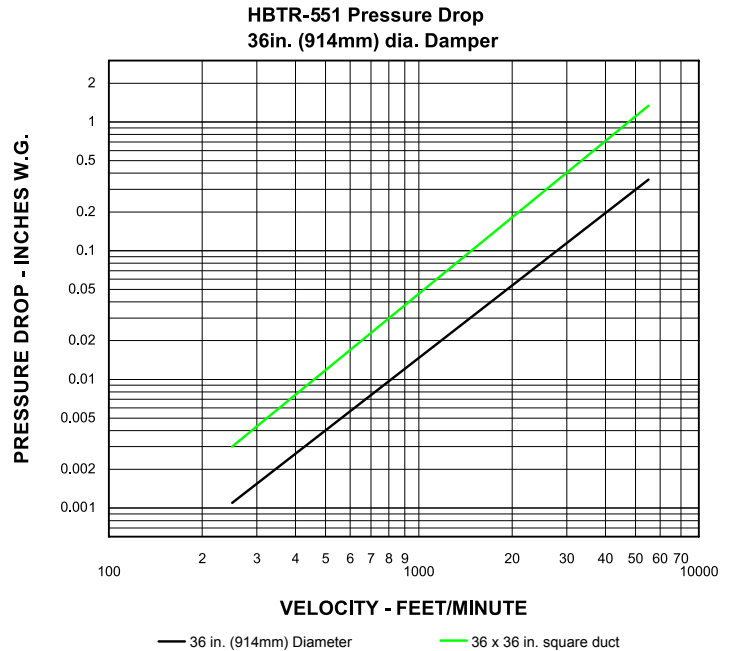
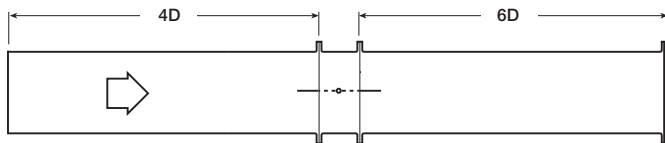

## Leakage

Every HBTR-551 is leakage tested at 30 in. wg (7.5 KPa) in accordance with AMCA 500-D before it leaves the factory. Greenheck does not ship a HBTR-551 unless it meets the requirements of the standard.

### Axle Seal Detail

The double gland axle seal is mounted externally for easy access and provides bubble tight performance.

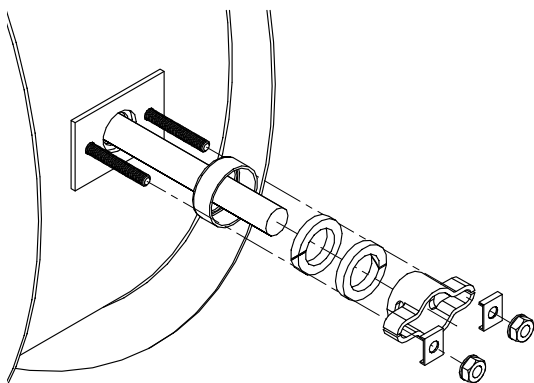

### Bearing Detail

The ball bearings are mounted outboard for easy access. The bearing comes with a grease fitting, allowing for easy lubrication (axle seals included but not shown in bearing detail).

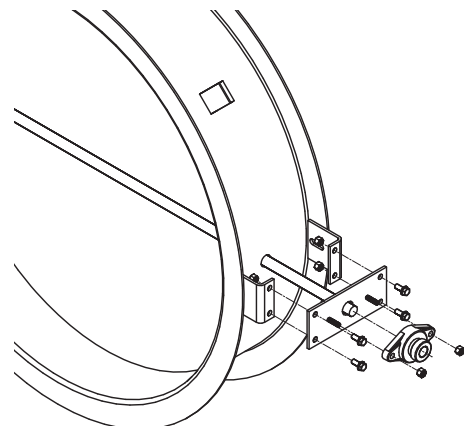

## Document Links

---

[Installation Instructions](#)

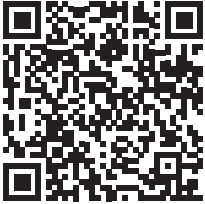

[Heavy Duty/Industrial  
Damper Catalog](#)



[Isolation Dampers](#)



[Heavy Duty/Industrial Damper  
Product Selection Guide](#)



[Warranty](#)

