

Application

Model HCD-221 is a heavy duty industrial isolation control damper with a flanged frame. The HCD-221 uses the blade design that we provide on our bubble tight damper. It is designed to provide shutoff with very low leakage in HVAC or industrial process control systems. This model is available with parallel or opposed blade action.

Damper Ratings

Velocity

Up to 4000 fpm (20.3 m/s)

Pressure

Up to 10 in. wg (2.5 kPa) - pressure differential

Temperature

-40°F to 400°F (-40°C to 204°C). Consult factory for temperatures.



Construction

	Standard	Optional
Frame Depth	8 in. (203 mm)	10 in. (254 mm)
Frame Material	Galvanized Steel	304SS, 316SS, Painted
Frame Material Thickness	14 ga. (2 mm)	10 ga. (3.5 mm) 12 ga. (2.7 mm)
Frame Type	Flanged channel	
Flange Width	2 in. (51 mm)	1½ in. (64 mm) 2½ in. (64 mm) 3 in. (76 mm)
Blade Material	Galvanized Steel	304SS, 316SS, Painted
Blade Thickness	14 ga. (2 mm) [†]	-
Blade Type	Flat Dual Skin w/ Perimeter Seal	
Blade Action	Parallel	Opposed
Blade Seals*	Silicone	EPDM
Linkage	Plated steel	304SS, 316SS
Axle Diameter**	¾ in. (19 mm) or 1 in. (25 mm)	
Axle Bearings	Stainless Steel Sleeve	External Bronze, External Ball, Outboard Bronze, Outboard Ball
Axle Material	Plated steel	303SS, 316SS
Axle Seals	O-ring	Double Gland
Paint Finishes	Mill Finish	Hi Pro Polyester, Industrial Epoxy
Mounting Holes	None	Standard Standard with corner holes

Actual Inside Dimension. The W dimension is ALWAYS parallel with the damper blade length.

Axles must always be the horizontal plane.

Size Limitations

W x H	Minimum Size	Maximum Size	
		Single Section	Multi - Section
Inches	6 x 6	48 x 60	96 x 60
mm	152 x 152	1219 x 1524	2438 x 1524

Options

- Wide range of actuators available
- Mounting holes in flanges

* Alternate seals increase damper torque, therefore limited sizing is available.

† with 14 ga. backing plate

** Axle diameter is based on damper size, required torque, and actuator selection. Consult factory for specific information.

Performance Data

Temperature Limitations

Blade seals: Silicone -40° to 400°F (-40° to 204°C)
EPDM -20° to 250°F (-29° to 121°C)
Neoprene -20° to 180°F (-29° to 82°C)

Pressure Drop Data

This pressure drop data was conducted in accordance with AMCA Standard 500-D using the three configurations shown. All data has been corrected to represent standard air at a density of .075 lb/ft³ (1.2 kg/m³).

Actual pressure drop found in any HVAC system is a combination of many factors. This pressure drop information along with an analysis of other system influences should be used to estimate actual pressure losses for a damper installed in a given HVAC system.

AMCA Test Figures

Figure 5.3 illustrates a fully ducted damper. This configuration has the lowest pressure drop of the three test configurations because the entrance and exit losses are minimized by straight duct runs upstream and downstream of the damper.

Figure 5.2 illustrates a ducted damper exhausting air into an open area. This configuration has a lower pressure drop than Figure 5.5 because the entrance losses are minimized by a straight duct run upstream of the damper.

Figure 5.5 illustrates a plenum mounted damper. This configuration has the highest pressure drop because of the high entrance and exit losses due to the sudden changes of area in the system.

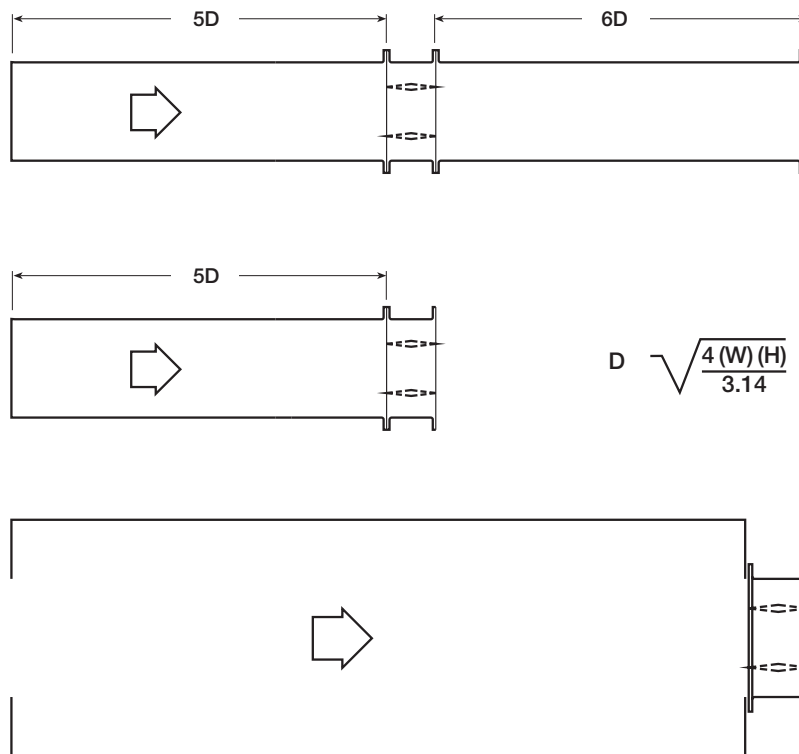

Performance Data

Pressure Drop

48 x 36 in. Damper
(1219mm x 914mm)

VELOCITY VS. PRESSURE DROP

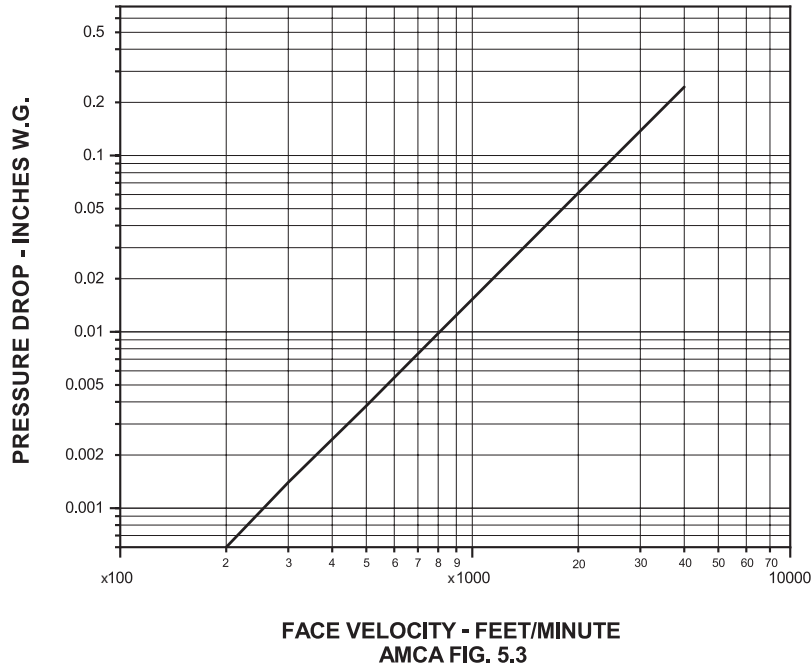

Leakage Data

Leakage testing was conducted in accordance with AMCA Standard 500-D and is expressed as CFM per sq. ft. of damper face area. All data has been corrected to represent standard air at a density of .075 lb/ft³ (1.2 kg/m³).

HCD-221 Leakage

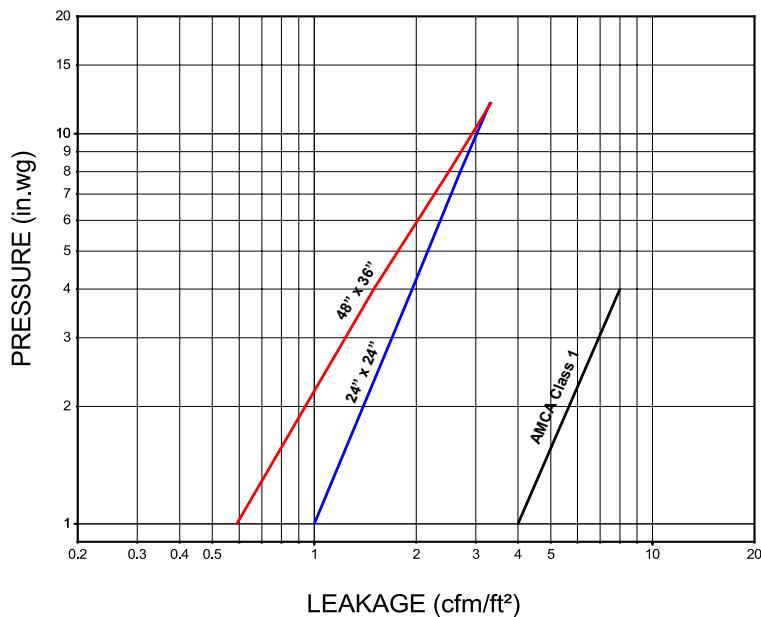

Mounting Holes

Bolt holes are available as an option. The standard pattern is $\frac{7}{16}$ in. (11mm) diameter holes (M dimension) spaced 4 in. (102mm) on center (L dimension). Custom bolt hole patterns are available. Contact factory for the limitations.

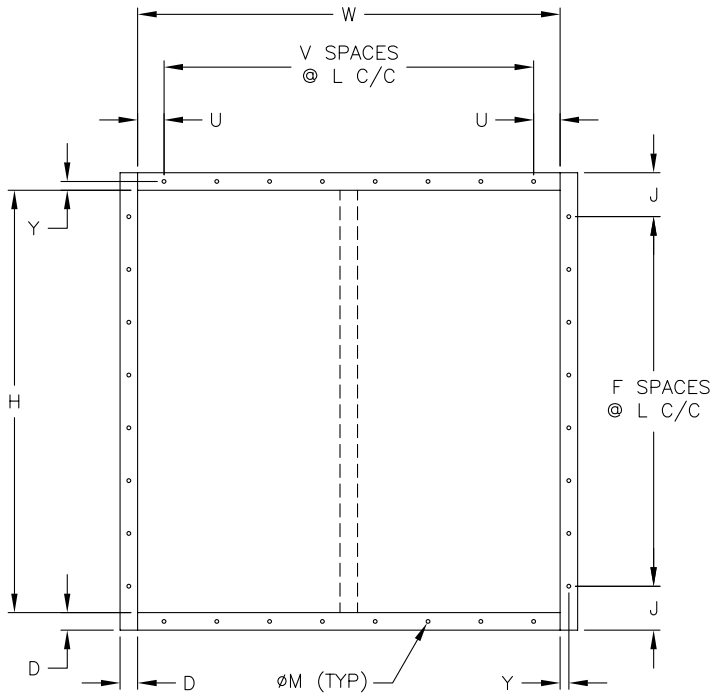

Standard Mounting Hole Pattern
Typical for single or double wide panel

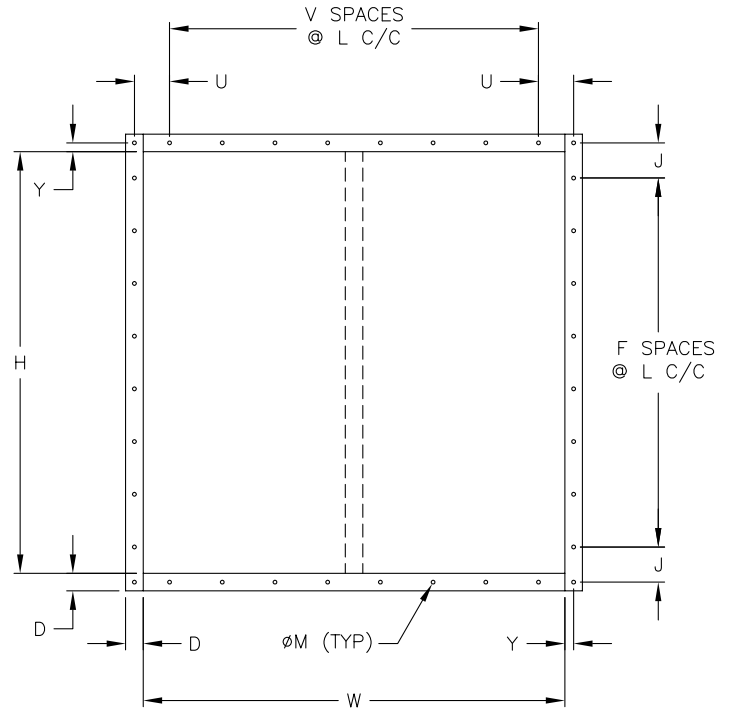

Standard Mounting Hole Pattern with Corner Holes
Typical for single or double wide panel

Links

[Installation Instructions](#)



[Heavy Duty and Industrial Damper Selection Guide](#)



[Heavy Duty and Industrial Damper Catalog](#)



[Damper Warranty Statement](#)

