

### Application

Model HCD-221 is a heavy duty industrial isolation control damper with a flanged frame. The HCD-221 uses the blade design that we provide on our bubble tight damper. It is designed to provide shutoff with very low leakage in HVAC or industrial process control systems. This model is available with parallel or opposed blade action.

### Damper Ratings

#### Velocity

Up to 4000 fpm (20.3 m/s)

#### Pressure

Up to 10 in. wg (2.5 kPa) - pressure differential

#### Temperature

-40°F to 400°F (-40°C to 204°C). Consult factory for temperatures.

### Construction

	Standard	Optional
<b>Frame Depth</b>	8 in. (203 mm)	10 in. (254 mm)
<b>Frame Material</b>	Galvanized Steel	304SS, 316SS
<b>Frame Material Thickness</b>	14 ga. (2 mm)	10 ga. (3.5 mm) 12 ga. (2.7 mm)
<b>Frame Type</b>	Flanged channel	
<b>Flange Width</b>	2 in. (51 mm)	1½ in. (64 mm) 2½ in. (64 mm) 3 in. (76 mm)
<b>Blade Material</b>	Galvanized Steel	304SS, 316SS
<b>Blade Thickness</b>	14 ga. (2 mm) <sup>†</sup>	-
<b>Blade Type</b>	Flat Dual Skin w/ Perimeter Seal	
<b>Blade Action</b>	Parallel	Opposed
<b>Blade Seals*</b>	Silicone	EPDM
<b>Linkage</b>	Plated steel	304SS, 316SS
<b>Axle Diameter**</b>	¾ in. (19 mm) or 1 in. (25 mm)	
<b>Axle Bearings</b>	External Stainless Steel Sleeve	External Bronze, External Ball, Outboard Bronze, Outboard Ball
<b>Axle Material</b>	Plated steel	303SS, 316SS
<b>Axle Seals</b>	O-ring	Double Gland
<b>Paint Finishes</b>	Mill Finish	Hi Pro Polyester, Industrial Epoxy
<b>Mounting Holes</b>	None	Standard, Standard with corner holes



Actual Inside Dimension. The W dimension is ALWAYS parallel with the damper blade length.  
Axles must always be the horizontal plane.

### Size Limitations

W x H	Minimum Size	Maximum Size	
		Single Section	Multi - Section
Inches	6 x 6	48 x 60	96 x 60
mm	152 x 152	1219 x 1524	2438 x 1524

### Options

- Wide range of actuators available
- Mounting holes in flanges

\* Alternate seals increase damper torque, therefore limited sizing is available.

<sup>†</sup> with 14 ga. backing plate

\*\* Axle diameter is based on damper size, required torque, and actuator selection. Consult factory for specific information.

## Performance Data

### Temperature Limitations

**Blade seals:** Silicone -40° to 400°F (-40° to 204°C)  
EPDM -20° to 250°F (-29° to 121°C)  
Neoprene -20° to 180°F (-29° to 82°C)

### Pressure Drop Data

This pressure drop data was conducted in accordance with AMCA Standard 500-D using the three configurations shown. All data has been corrected to represent standard air at a density of .075 lb/ft<sup>3</sup> (1.2 kg/m<sup>3</sup>).

Actual pressure drop found in any HVAC system is a combination of many factors. This pressure drop information along with an analysis of other system influences should be used to estimate actual pressure losses for a damper installed in a given HVAC system.

### AMCA Test Figures

**Figure 5.3** illustrates a fully ducted damper. This configuration has the lowest pressure drop of the three test configurations because the entrance and exit losses are minimized by straight duct runs upstream and downstream of the damper.

**Figure 5.2** illustrates a ducted damper exhausting air into an open area. This configuration has a lower pressure drop than Figure 5.5 because the entrance losses are minimized by a straight duct run upstream of the damper.

**Figure 5.5** illustrates a plenum mounted damper. This configuration has the highest pressure drop because of the high entrance and exit losses due to the sudden changes of area in the system.

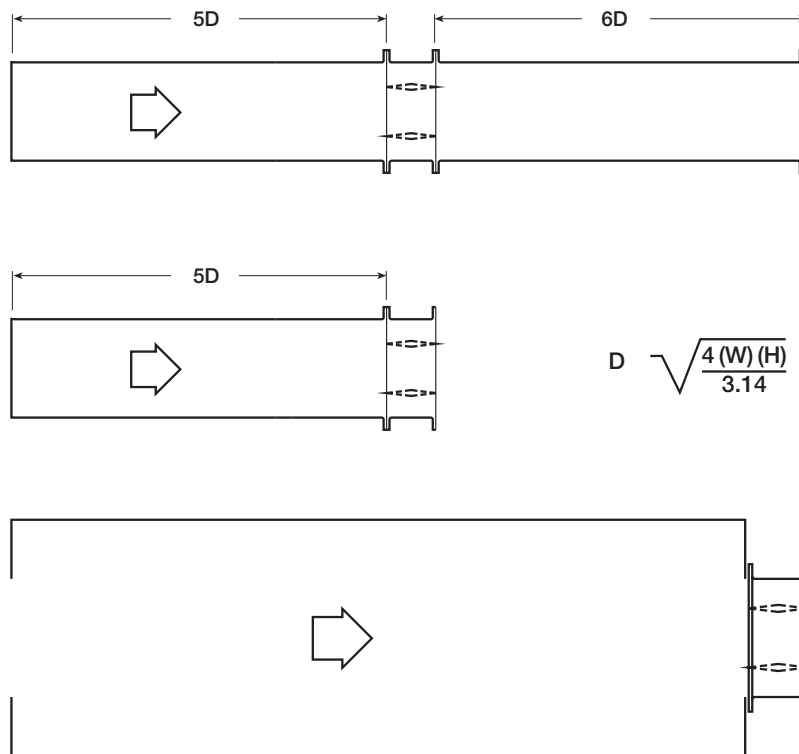

## Performance Data

### Pressure Drop

48 x 36 in. Damper  
(1219mm x 914mm)

#### VELOCITY VS. PRESSURE DROP

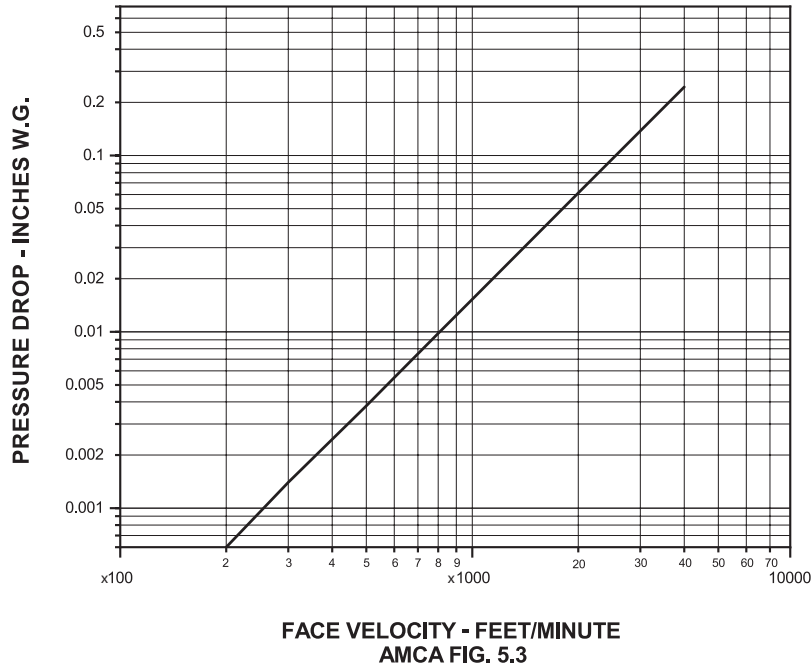

## Leakage Data

Leakage testing was conducted in accordance with AMCA Standard 500-D and is expressed as CFM per sq. ft. of damper face area. All data has been corrected to represent standard air at a density of .075 lb/ft<sup>3</sup> (1.2 kg/m<sup>3</sup>).

### HCD-221 Leakage

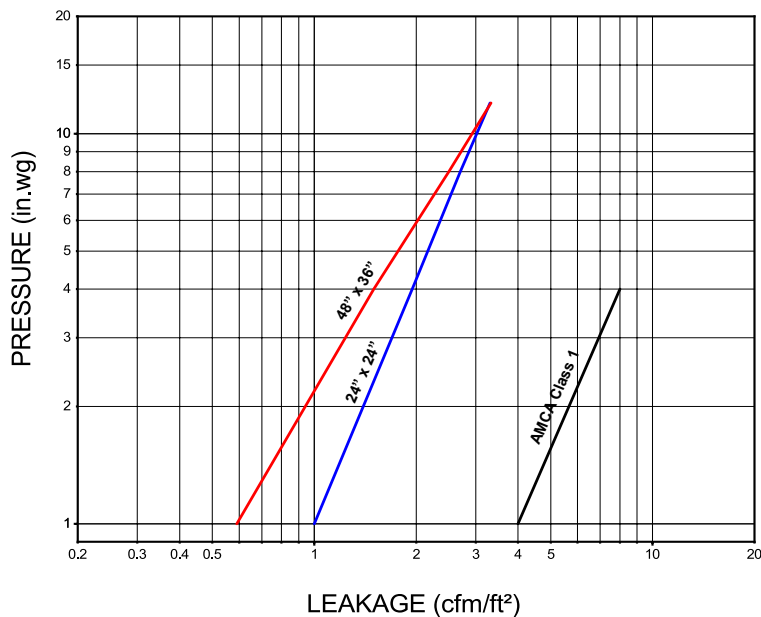

# Mounting Holes

Bolt holes are available as an option. The standard pattern is  $\frac{7}{16}$  in. (11mm) diameter holes (M dimension) spaced 4 in. (102mm) on center (L dimension). Custom bolt hole patterns are available. Contact factory for the limitations.

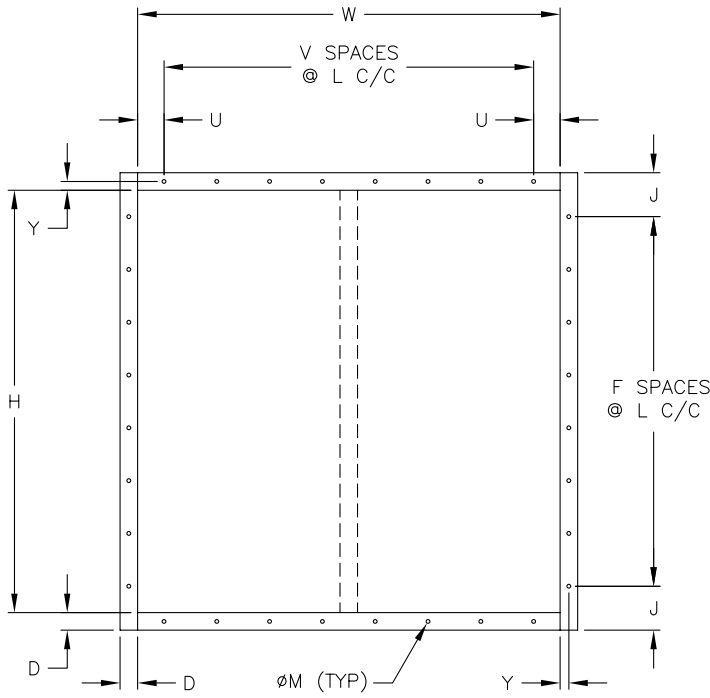

Standard Mounting Hole Pattern  
Typical for single or double wide panel

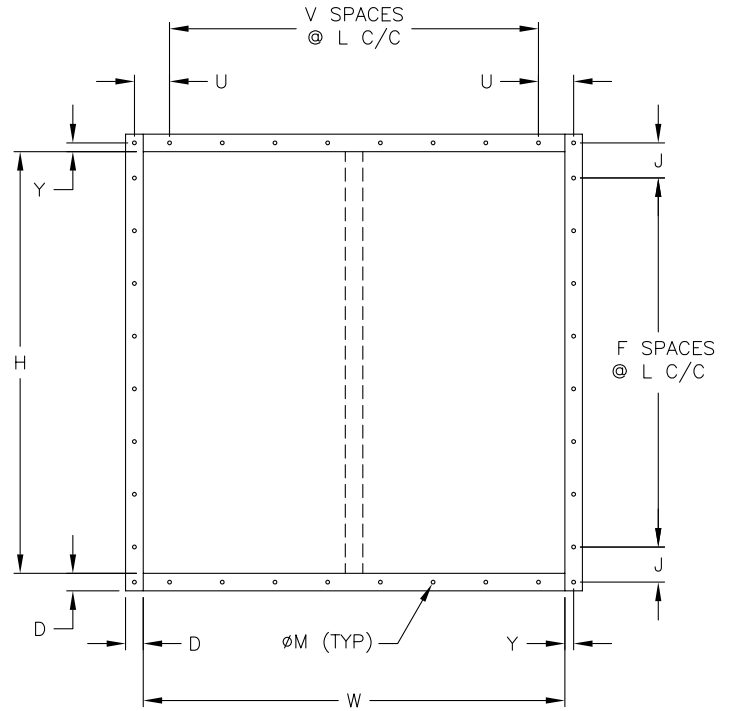

Standard Mounting Hole Pattern with Corner Holes  
Typical for single or double wide panel

## Links



[INSTALLATION](#)



[CATALOG](#)



[HD PRODUCT GUIDE](#)



[SELECTION GUIDE](#)



[WARRANTY](#)