

### Application

Model HCDR-250 is a heavy duty round industrial control damper with a flanged style frame. It is designed to control airflow and provide shut off in HVAC or industrial process control systems.

### Ratings

#### Velocity

Up to 5150 fpm (26.5 m/s)

#### Temperature

-40° to 600°F (-40° to 315°C) Consult factory for other temperatures

#### Pressure

Up to 13.5 in. wg (3.4 kPa) - differential pressure

### Construction

	Standard	Optional
<b>Frame Material</b>	Painted	304SS or 316SS
<b>Frame Type</b>	Flanged channel	-
<b>Blade Material</b>	Painted	304SS or 316SS
<b>Blade Seals</b>	None	EPDM, Silicone, Fiberglass, or Ceramic
<b>Blade Stop</b>	Pin stop	Rolled bar
<b>Blade Type</b>	Round butterfly	
<b>Axle Bearing</b>	External bronze through 56 in. (1422 mm); External ball above 56 in. (1422 mm) diameter	External ball, Outboard bronze, Outboard ball, Outboard carbon
<b>Axle Material</b>	Plated steel	303SS or 316SS
<b>Axle Seals</b>	None	O-ring, Double gland
<b>Paint Finishes</b>	Hi Pro Polyester	Hi Temperature Flame Control, Hi Temperature Silver, Industrial Epoxy, None
<b>Mounting Holes</b>	None	Parallel, Straddle

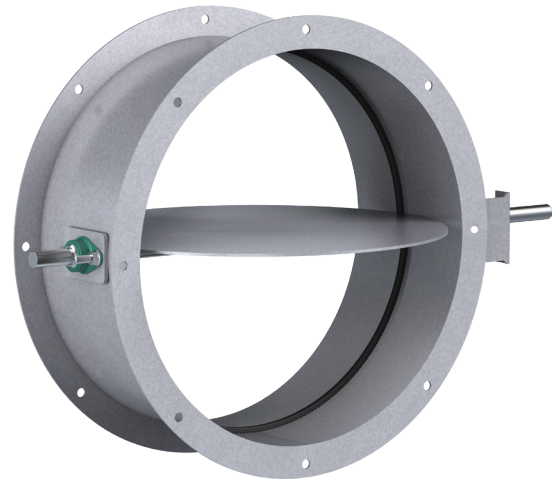

\* Actual Inside Dimension

Diameter	Minimum Size	Maximum Size
<b>Inches</b>	4	72
<b>mm</b>	102	1829

### Features

- Wide mounting flanges can be ordered with bolt holes, customized to match your requirements.
- Rolled bar stops are required when blade seal is selected.
- Wide range of actuators available

## Dimensions

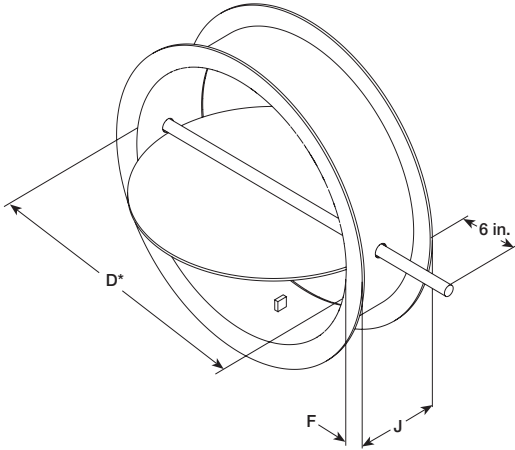

Diameter D Inches (mm)		Frame Depth J Inches (mm)	Frame & Flange Gauge (mm)	Flange Width F Inches (mm)	Axle Diameter Inches (mm)	Blade Thickness Gauge (mm)
Above	Through					
3.99 (101)	12 (305)	6 (152)	12 (2.7)	1.25 (32)	0.5* (13)	10 (3.5)
12 (305)	16 (406)	8 (203)	12 (2.7)	1.5 (32)	0.5* (13)	0.188 (4.8)
16 (406)	24 (610)	8 (203)	12 (2.7)	1.5 (32)	0.75 (19)	0.188 (4.8)
24 (610)	36 (914)	8 (203)	10 (3.5)	2.0 (51)	0.75 (19)	0.188 (4.8)
36 (914)	44 (1118)	8 (203)	10 (3.5)	2.0 (51)	1.00 (25)	0.188 (4.8)
44 (1118)	48 (1219)	8 (203)	0.188 (4.8)	2.0 (51)	1.25 (32)	0.188 (4.8)
48 (1219)	56 (1422)	8 (203)	0.188 (4.8)	2.5 (64)	1.25 (32)	0.188 (4.8)
56 (1422)	60 (1524)	10 (254)	0.188 (4.8)	2.5 (64)	1.50 (38)	0.188 (4.8)
60 (1524)	72 (1829)	10 (254)	0.188 (4.8)	3 (76)	1.50 (38)	0.188 (4.8)

\* The axle diameter is .75 in (19mm) when outboard carbon bearings are selected for dampers 16 inches and below.

## Options

### Bearing and Shaft

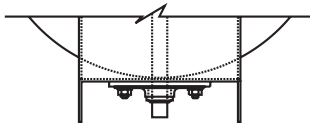

External Mounted Ball or Sleeve Bearing (Bronze Sleeve Standard, Ball Optional)

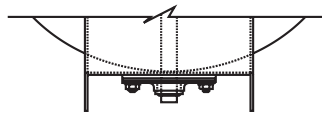

External Mounted Bronze Sleeve Bearing with O-Ring (Optional)

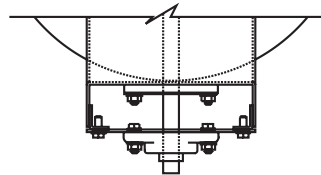

O-Ring Shaft Seal with Outboard Mounted Bearing (Optional)

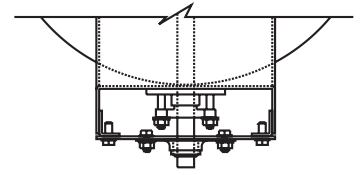

Double Gland Stuffing Box with Outboard Mounted Bearing (Optional)

### Blade Seal (Rolled Bar Blade Stops Required)

**Standard** - Does not include Blade Seals

**Optional** - EPDM Blade Seals (250°F [121°C] max.)

**Optional** - Silicone Rubber Blade Seals (400°F [204°C] max.)

**Optional** - Fiberglass or Ceramic Blade Seals (600°F [315°C] max.)

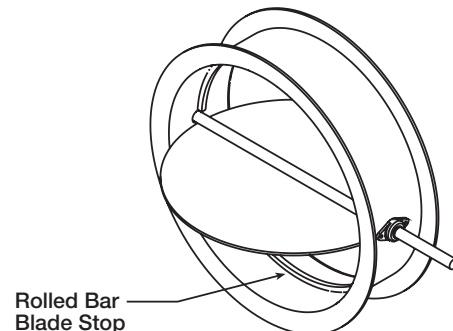

## Performance Data

### AMCA Test Figure 5.3

Figure 5.3 illustrates a fully ducted damper. This configuration has low pressure drop because entrance and exit losses are minimized by straight duct runs upstream and downstream of the damper.

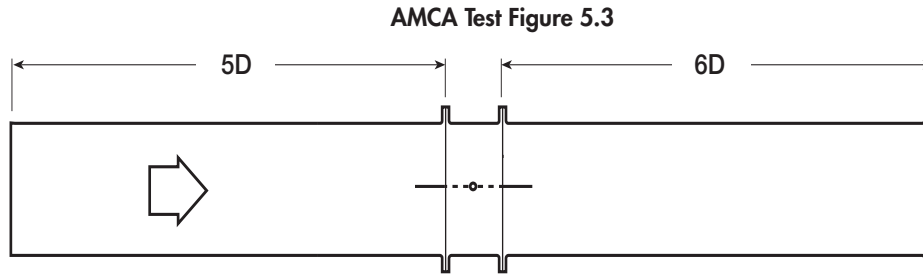

### Pressure Drop Data

This pressure drop data was conducted in accordance with AMCA Standard 500-D using Test Figure 5.3. All data has been corrected to represent standard air at a density of 0.075 lb/ft<sup>3</sup> (1.2 kg/m<sup>3</sup>).

Actual pressure drop found in any HVAC system is a combination of many factors. This pressure drop information along with an analysis of other system influences should be used to estimate actual pressure losses for a damper installed in a given HVAC system.

NOTE:

PS refers to damper with standard pin blade stop

BS refers to damper with rolled bar blade stop

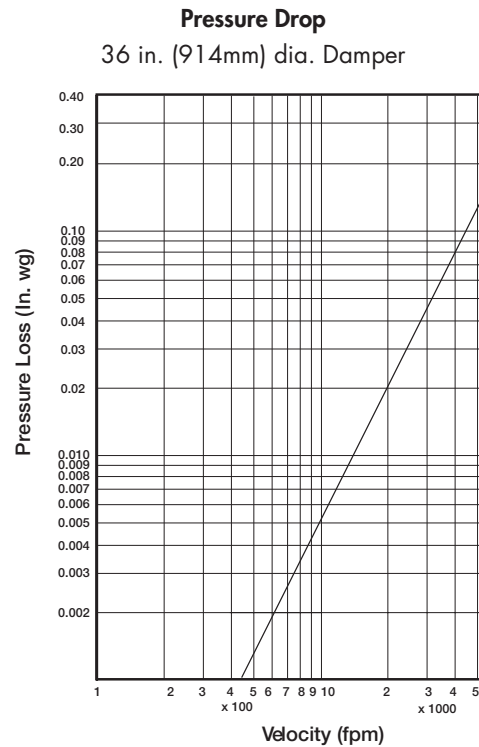
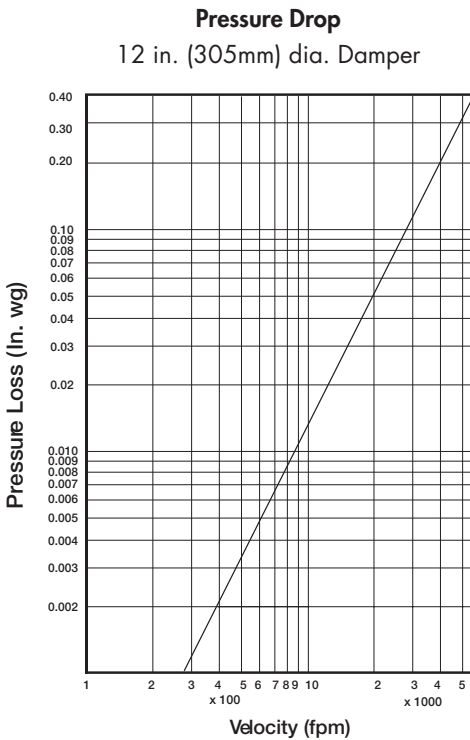

# Leakage

Damper leakage (with blades fully closed) varies based on the type of blade stops and low leakage seals applied. Model HCDR-250 is available with no seals (standard) or with EPDM or silicone rubber blade seals. Leakage testing was conducted in accordance with AMCA Standard 500-D and is expressed as cfm/ft<sup>2</sup> of damper face area. All data has been corrected to represent standard air at a density of 0.075 lb/ft<sup>3</sup> (1.2 kg/m<sup>3</sup>).

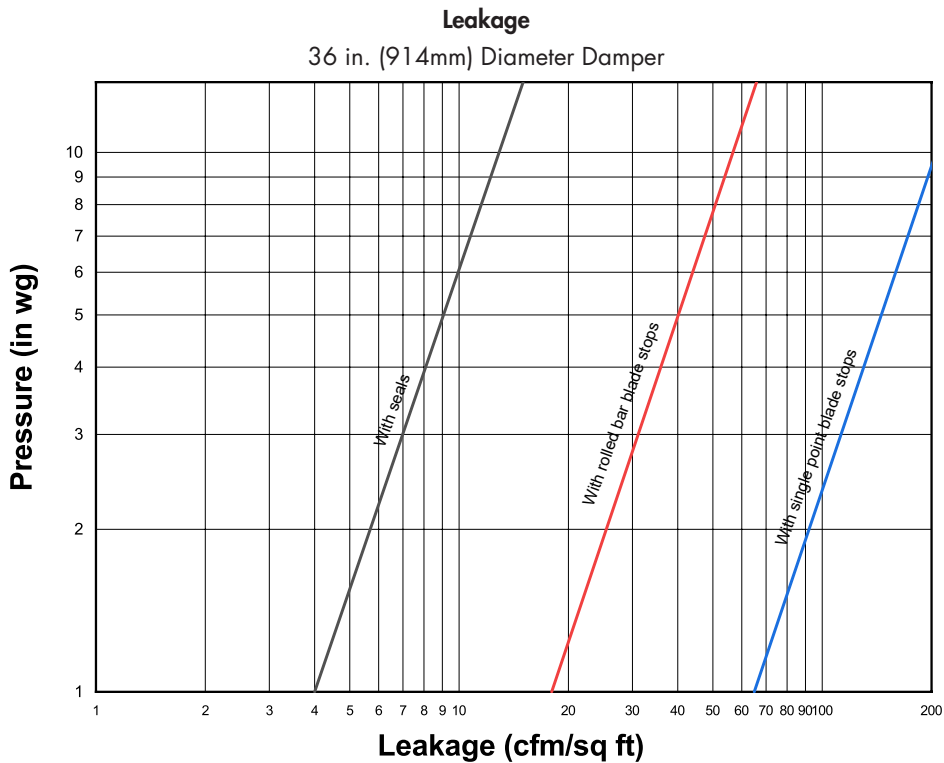
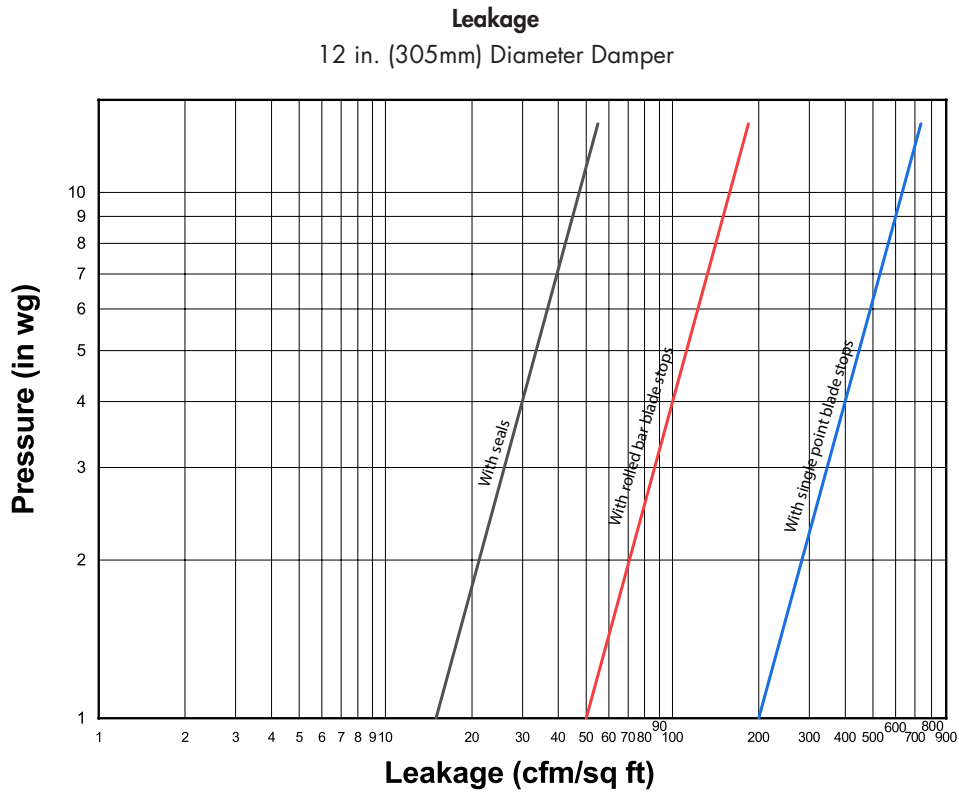

# Mounting Holes

The recommended bolt hole pattern is shown in the table below. Customer must specify bolt holes that are parallel to the axle centerline or that straddle the axle centerline as shown in the diagrams below. The factory can also provide bolt hole sizes and patterns other than those shown.

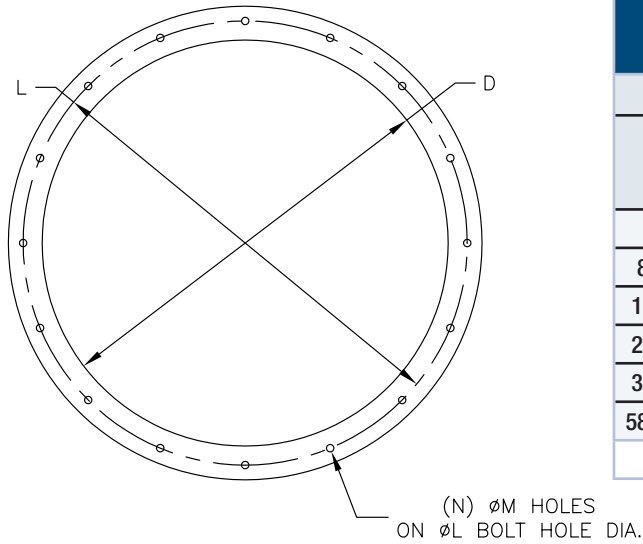

Recommended Bolt Hole Pattern (Bolt Holes Parallel to Axle Centerline)					
Diameter Inches (mm)		Number of Holes	Mounting Hole Diameter in. (mm) N	Bolt Circle Diameter L	Degrees Between Holes
Above	Through				
4 (102)	8 (203)	4	3/8 (9.5)	*	90
8.001 (203)	18 (457)	8	7/16 (11)	*	45
18.001 (457)	24 (610)	12	7/16 (11)	*	30
24.001 (610)	36 (914)	16	7/16 (11)	*	22½
36.001 (914)	58 (1473)	24	7/16 (11)	*	15
58.001 (1473)	72 (1829)	32	9/16 (14)	*	11¼

\* Bolt Circle Diameter = Damper Diameter + Flange Height + ¼ in. (6mm)

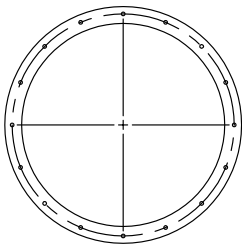

Parallel on Centerline

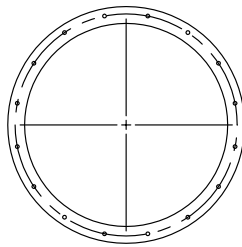

Straddle on Centerline

## Document Links

[Installation Instructions](#)



[Heavy Duty/Industrial Damper Catalog](#)



[Heavy Duty and Industrial Product Selection Guide](#)



[Damper Interactive Selection Guide](#)



[Warranty](#)

