

Application

Model HCDR-351 is a heavy duty round industrial isolation damper with a flanged style frame. It is designed to provide tight shutoff with very low leakage in HVAC or industrial process control systems.

Ratings

Velocity

Up to 6500 fpm (33 m/s)

Pressure

Up to 20 in. wg (5 kPa) pressure differential

Temperature

-40°F to 400°F (-40°C to 204°C)

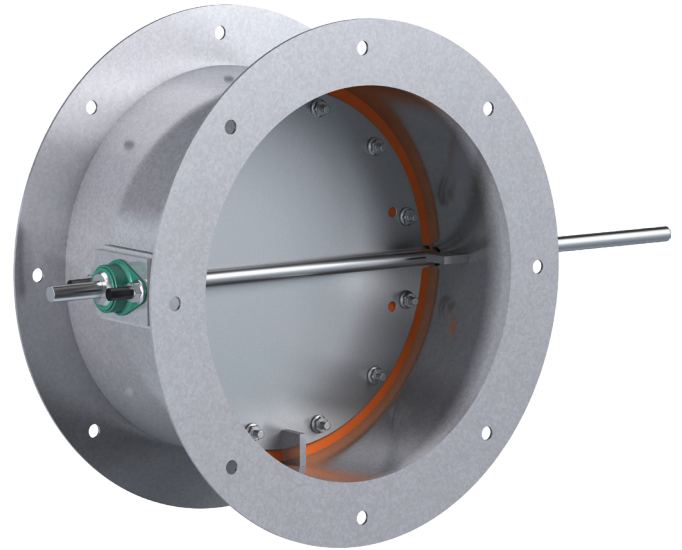

Size is actual inside dimension.

Construction

	Standard	Optional
Frame Material	Painted Steel	304SS, 316SS
Frame Type	Flanged Channel	
Blade Material	Painted Steel	304SS, 316SS
Blade Seals	Silicone	EPDM
Blade Type	Round Butterfly	
Blade Stop	Pin Stop	
Axle Bearing	External Bronze	External Ball, Outboard Bronze, Outboard Ball
Axle Material*	Plated Steel	303SS, 316SS
Axle Seals	O-ring	Double Gland
Paint Finishes	Hi Pro Polyester	Hi Temperature Flame Control, Hi Temperature Silver, Industrial Epoxy, Mill Finish (304SS, 316SS)
Mounting Holes	None	On Centerline, Straddle Centerline

* Axle materials may change to 316SS as required for proper operation.

Size Limitations

Diameter	Minimum Size	Maximum Size
Inches	4	48
mm	102	1219

Features

- Wide mounting flanges can be ordered with bolt holes, customized to match your requirements.
- Wide range of actuators available.

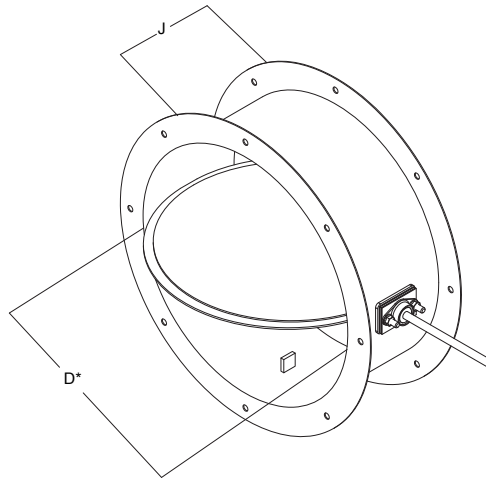

Diameter D Inches (mm)		Frame Depth J Inches (mm)	Frame & Flange Gauge (mm)	Flange Width F Inches (mm)	Axle Diameter Inches (mm)	Blade Thickness Gauge (mm)
Above	Through					
5.99 (152)	12 (305)	6 (152)	12 (2.7mm)	1.5 (38)	0.5 (13)	12 (2.7)
12 (305)	24 (610)	8 (203)	10 (3.5)	1.5 (38)	0.75 (19)	10 (3.5)
24 (610)	36 (914)	8 (203)	0.188 (4.7)	2 (51)	1 (25)	10 (3.5)
36 (914)	48 (1219)	8 (203)	0.188 (4.7)	2 (51)	1.25 (31.7)	0.188 (4.7)

Bolt Holes

The recommended bolt hole pattern is shown in the table below. Customer must specify bolt holes that are parallel to the axle centerline or that straddle the axle centerline as shown in the diagrams below. The factory can also provide bolt hole sizes and patterns other than those shown.

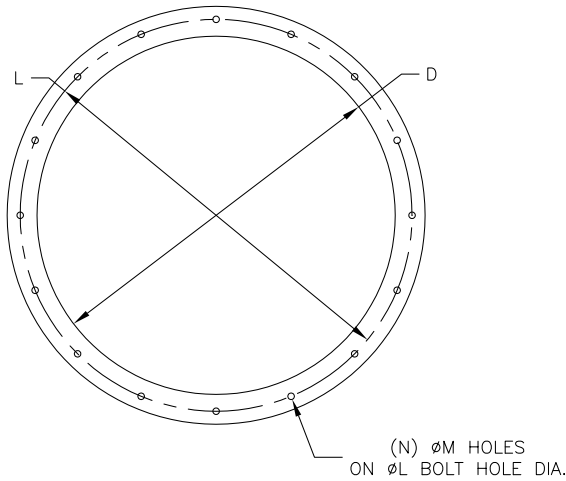

Recommended Bolt Hole Pattern (Bolt Holes Parallel to Axle Centerline)					
Diameter Inches (mm)		Number of Holes	Mounting Hole Diameter in. (mm) N	Bolt Circle Diameter L	Degrees Between Holes
Above	Through				
4 (102)	8 (203)	4	$\frac{3}{8}$ (9.5)	*	90
8.001 (203)	18 (457)	8	$\frac{7}{16}$ (11)	*	45
18.001 (457)	24 (610)	12	$\frac{7}{16}$ (11)	*	30
24.001 (610)	36 (914)	16	$\frac{7}{16}$ (11)	*	22½
36.001 (914)	48 (1219)	24	$\frac{7}{16}$ (11)	*	15

* Bolt Circle Diameter = Damper Diameter + Flange Height + ¼ in. (6mm)

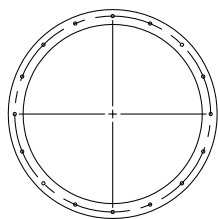

On Centerline

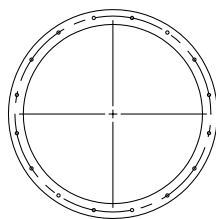

Straddle Centerline

Performance Data

AMCA Test Figure 5.3

Figure 5.3 illustrates a fully ducted damper. This configuration has low pressure drop because entrance and exit losses are minimized by straight duct runs upstream and downstream of the damper.

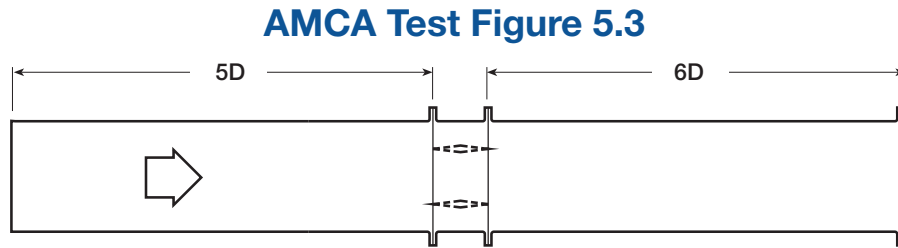

Pressure Drop Data

This pressure drop data was conducted in accordance with AMCA Standard 500-D using Test Figure 5.3. All data has been corrected to represent standard air at a density of 0.075 lb/ft³ (1.2 kg/m³).

Actual pressure drop found in any HVAC system is a combination of many factors. This pressure drop information along with an analysis of other system influences should be used to estimate actual pressure losses for a damper installed in a given HVAC system.

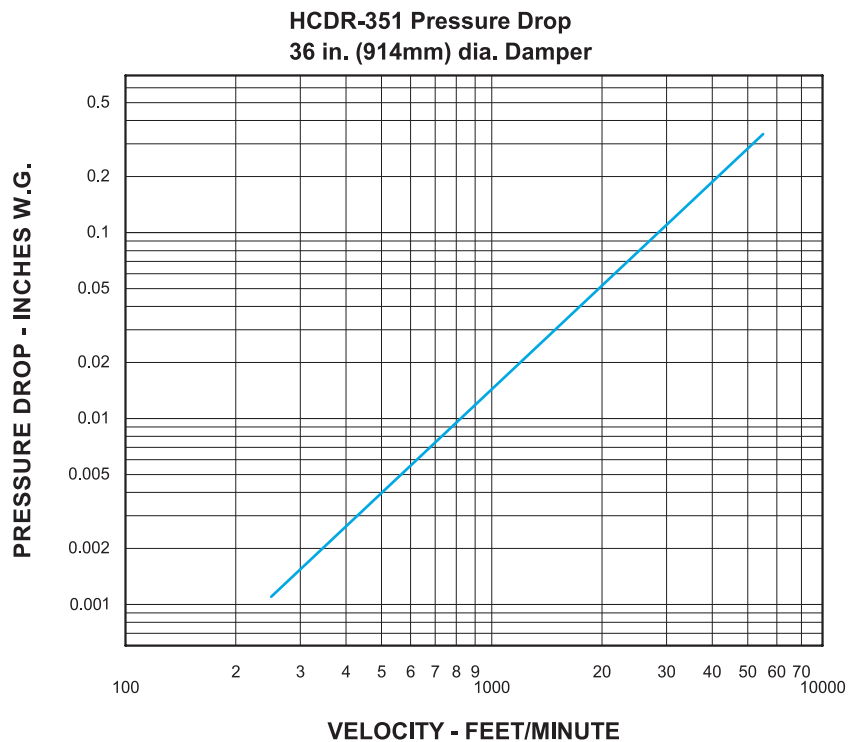

Leakage Data

HCDR-351's tight shutoff design provides very low leakage, which is tested to be better than 0.029 CFM per inch of perimeter requirements. The graph below shows the leakage value for a range of sizes tested in CFM per square foot terms.

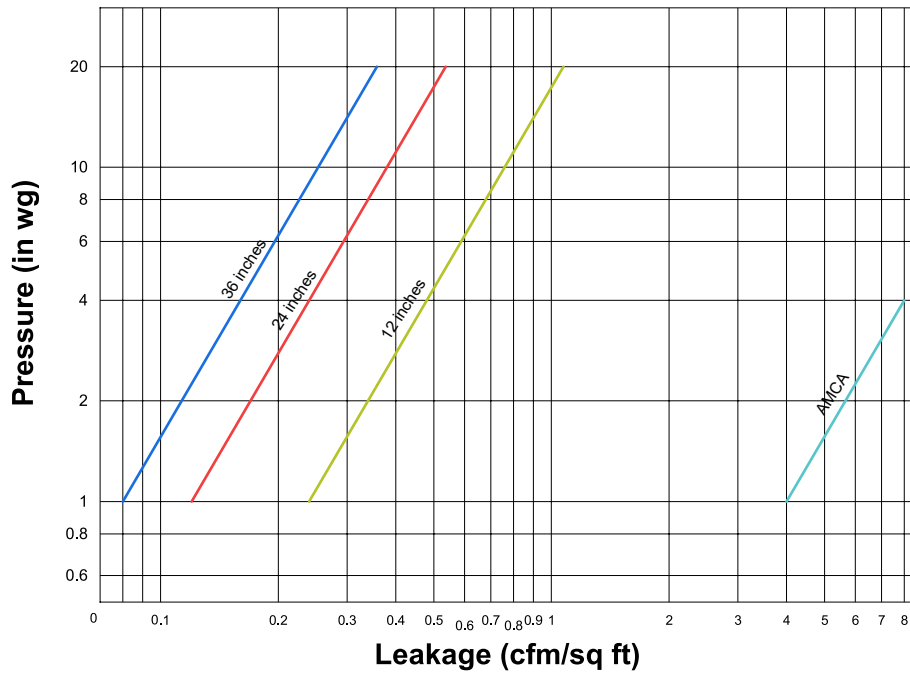

Document Links



[INSTALLATION](#)



[CATALOG](#)



[SELECTION GUIDE](#)



[DAMPER SELECTION GUIDE](#)



[WARRANTY](#)