

### Application

Models HTOD-330 and HTOD-331 are heavy duty backdraft damper with double flanged channel frame and double thickness fabricated airfoil blades. The HTOD damper series are designed to protect against tornadoes and instantaneous pressure changes. External clevis type linkage and external mount ball bearings are standard.

Model HTOD-330 will close in the same direction as normal flow and HTOD-331 will close in the opposite direction as normal flow.

### Damper Ratings

#### Velocity

Up to 6400 fpm (32.5 m/s)

#### Pressure

Up to 83 in. wg (20.7 kPa) (3 psi) - pressure differential

#### Temperature

-40°F to 250°F (-40°C to 121°C)

#### Pressure Rise or Decrease

3 psi

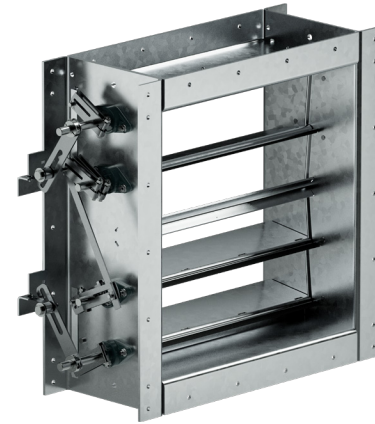

\* Actual Inside Dimension.

\*\* The W dimension is ALWAYS parallel with the damper blade length.

### Construction

	Standard	Optional
<b>Frame Material</b>	Painted Steel	304SS or 316SS
<b>Frame Material Thickness</b>	¼ in. (6.3mm)	-
<b>Frame Type</b>	12 in. x 3 in. (305mm x 76mm) flanged channel	-
<b>Blade Material</b>	Galvaneal	304SS or 316SS
<b>Blade Type</b>	Airfoil	-
<b>Blade Thickness</b>	16 ga. (1.6mm)	-
<b>Axle Material</b>	Plated steel, full length with reinforcing tube	303SS or 316SS
<b>Axle Size</b>	¾ in. (19mm)	-
<b>Axle Bearings</b>	External Ball	-
<b>Blade Seals</b>	EPDM	Silicone
<b>Jamb Seals</b>	EPDM	Silicone
<b>Linkage Material</b>	Plated Steel	304SS or 316SS
<b>Painted Finishes</b>	Hi Pro Polyester on damper frame; Mill galvanized on blades	Industrial Epoxy; Mill (304SS or 316SS)
<b>Air Flow</b>	Horizontal	-
<b>Mounting Holes</b>	None	Standard; Standard w/corner holes

### Size Limitations

W x H	Minimum Size	Maximum Size
		Single Section
Inches	12 x 12	48 x 60
mm	305 x 305	1219 x 1524

# Performance Data

## Pressure Drop Data (not valid for counter flow operation)

This pressure drop data was conducted in accordance with AMCA Standard 500-D using the three configurations shown. All data has been corrected to represent standard air at a density of .075 lb/ft<sup>3</sup> (1.2 kg/m<sup>3</sup>).

Actual pressure drop found in any HVAC system is a combination of many factors. This pressure drop information along with an analysis of other system influences should be used to estimate actual pressure losses for a damper installed in a given HVAC system.

### AMCA Test Figures

**Figure 5.3** illustrates a fully ducted damper. This configuration has the lowest pressure drop of the three test configurations because the entrance and exit losses are minimized by straight duct runs upstream and downstream of the damper.

**Figure 5.2** illustrates a ducted damper exhausting air into an open area. This configuration has a lower pressure drop than Figure 5.5 because the entrance losses are minimized by a straight duct run upstream of the damper.

**Figure 5.5** illustrates a plenum mounted damper. This configuration has the highest pressure drop because of the high entrance and exit losses due to the sudden changes of area in the system.

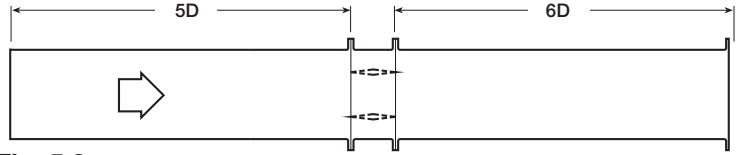

Fig. 5.3

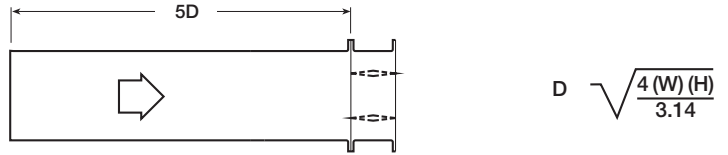

Fig. 5.2

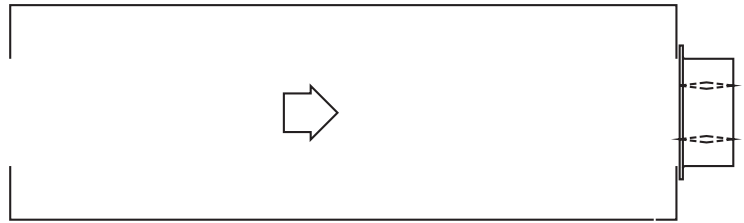
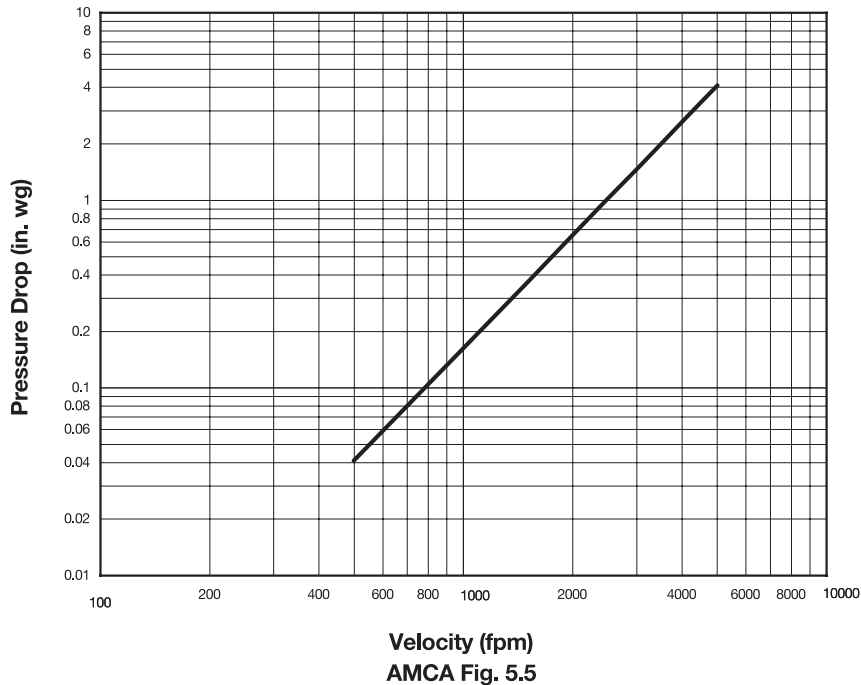

Fig. 5.5

## Pressure Drop

36 in. x 36 in. (914mm x 914mm) Damper



# Model HTOD-330 and HTOD-331 Difference

### HTOD-330

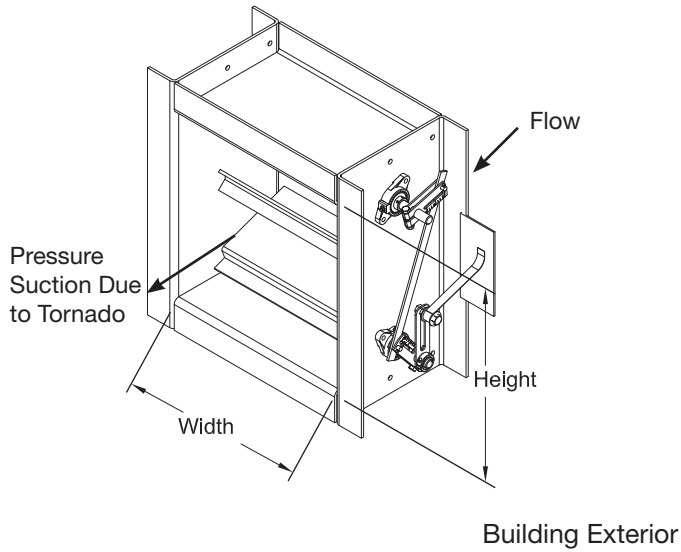

### HTOD-331

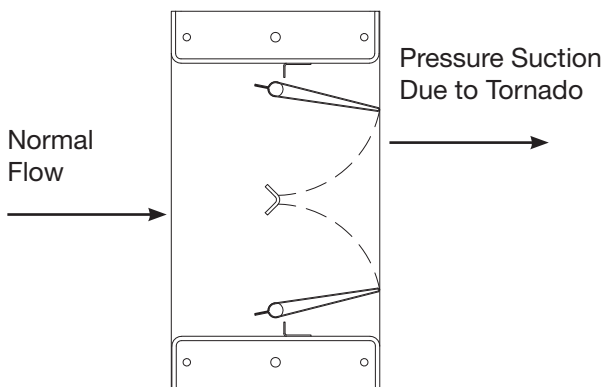
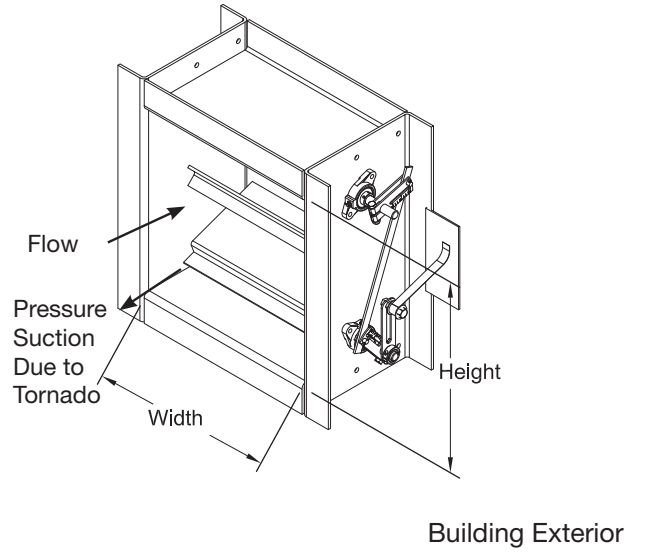

### Model HTOD-330

This model closes in the same direction as normal flow.

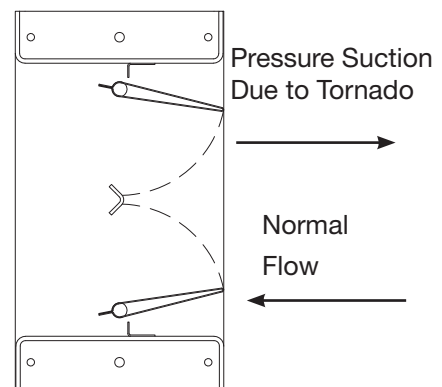

### Model HTOD-331

This model closes in the opposite direction as normal flow.

# Mounting Holes

Bolt holes are available as an option. The standard pattern is 7/16 in. (11mm) diameter holes (M dimension) spaced 6 in. (152mm) on center (L dimension). Custom bolt hole patterns are available. Contact factory for the limitations.

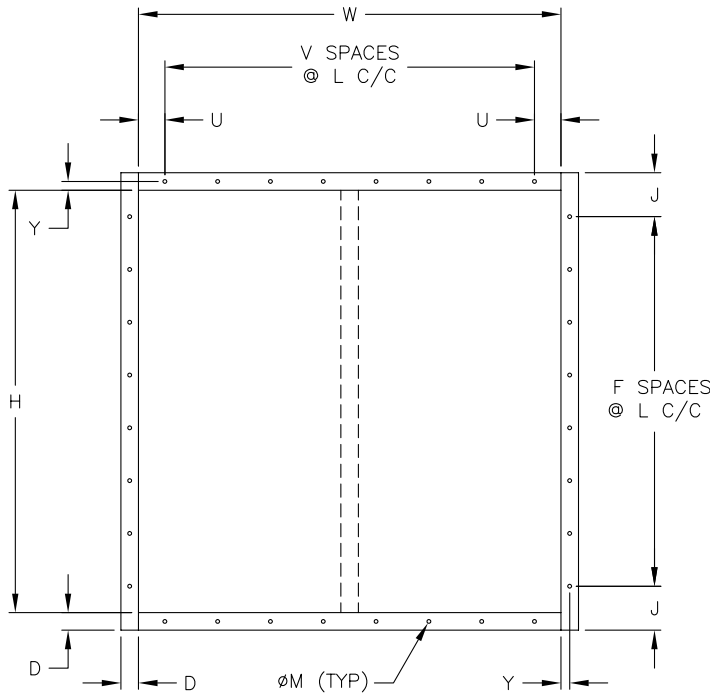

Standard Mounting Hole Pattern  
Typical for single or double wide panel

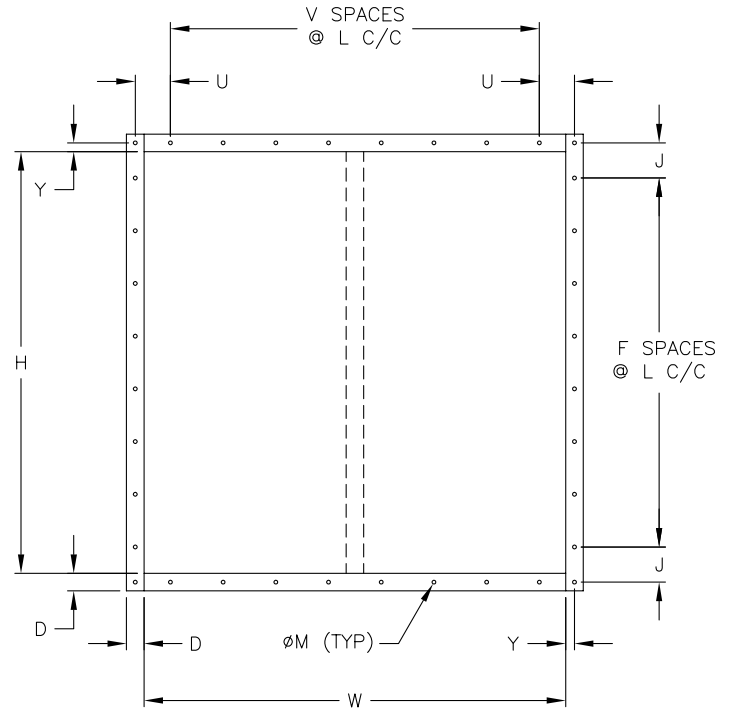

Standard Mounting Hole Pattern with Corner Holes  
Typical for single or double wide panel

## Links



[INSTALLATION](#)



[CATALOG](#)



[HEAVY DUTY  
SELECTION GUIDE](#)



[SELECTION GUIDE](#)



[WARRANTY](#)