

Application

Models HTOD-330 and HTOD-331 are heavy duty backdraft damper with double flanged channel frame and double thickness fabricated airfoil blades. The HTOD damper series are designed to protect against tornadoes and instantaneous pressure changes. External clevis type linkage and external mount ball bearings are standard.

Model HTOD-330 will close in the same direction as normal flow and HTOD-331 will close in the opposite direction as normal flow.

Damper Ratings

Velocity

Up to 6400 fpm (32.5 m/s)

Pressure

Up to 83 in. wg (20.7 kPa) (3 psi) - pressure differential

Temperature

-40°F to 250°F (-40°C to 121°C)

Pressure Rise or Decrease

3 psi

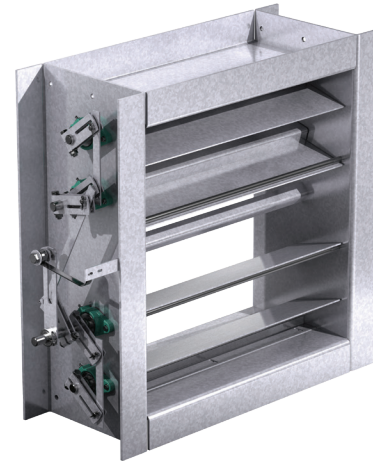

* Actual Inside Dimension.

** The W dimension is ALWAYS parallel with the damper blade length.

Construction

	Standard	Optional
Frame Material	Painted Steel	304SS or 316SS
Frame Material Thickness	¼ in. (6.3mm)	-
Frame Type	12 in. x 3 in. (305mm x 76mm) flanged channel	-
Blade Material	Galvaneal	304SS or 316SS
Blade Type	Airfoil	-
Blade Thickness	16 ga. (1.6mm)	-
Axle Material	Plated steel, full length with reinforcing tube	303SS or 316SS
Axle Size	¾ in. (19mm)	-
Axle Bearings	External Ball	-
Blade Seals	EPDM	Silicone
Jamb Seals	EPDM	Silicone
Linkage Material	Plated Steel	304SS or 316SS
Painted Finishes	Hi Pro Polyester on damper frame; Mill galvanized on blades	Industrial Epoxy; Mill (304SS or 316SS)
Air Flow	Horizontal	-
Mounting Holes	None	Standard; Standard w/corner holes

Size Limitations

W x H	Minimum Size	Maximum Size
		Single Section
Inches	12 x 12	48 x 60
mm	305 x 305	1219 x 1524

Performance Data

Pressure Drop Data (not valid for counter flow operation)

This pressure drop data was conducted in accordance with AMCA Standard 500-D using the three configurations shown. All data has been corrected to represent standard air at a density of .075 lb/ft³ (1.2 kg/m³).

Actual pressure drop found in any HVAC system is a combination of many factors. This pressure drop information along with an analysis of other system influences should be used to estimate actual pressure losses for a damper installed in a given HVAC system.

AMCA Test Figures

Figure 5.3 illustrates a fully ducted damper. This configuration has the lowest pressure drop of the three test configurations because the entrance and exit losses are minimized by straight duct runs upstream and downstream of the damper.

Figure 5.2 illustrates a ducted damper exhausting air into an open area. This configuration has a lower pressure drop than Figure 5.5 because the entrance losses are minimized by a straight duct run upstream of the damper.

Figure 5.5 illustrates a plenum mounted damper. This configuration has the highest pressure drop because of the high entrance and exit losses due to the sudden changes of area in the system.

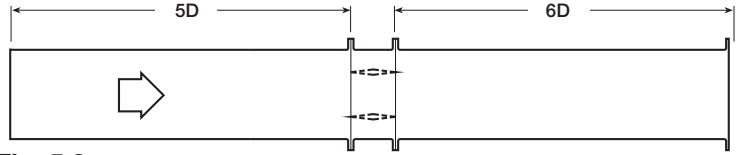

Fig. 5.3

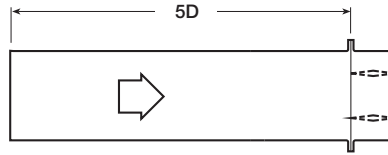

Fig. 5.2

$$D = \sqrt{\frac{4(W)(H)}{3.14}}$$

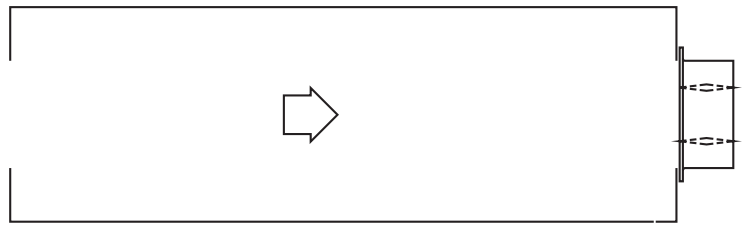
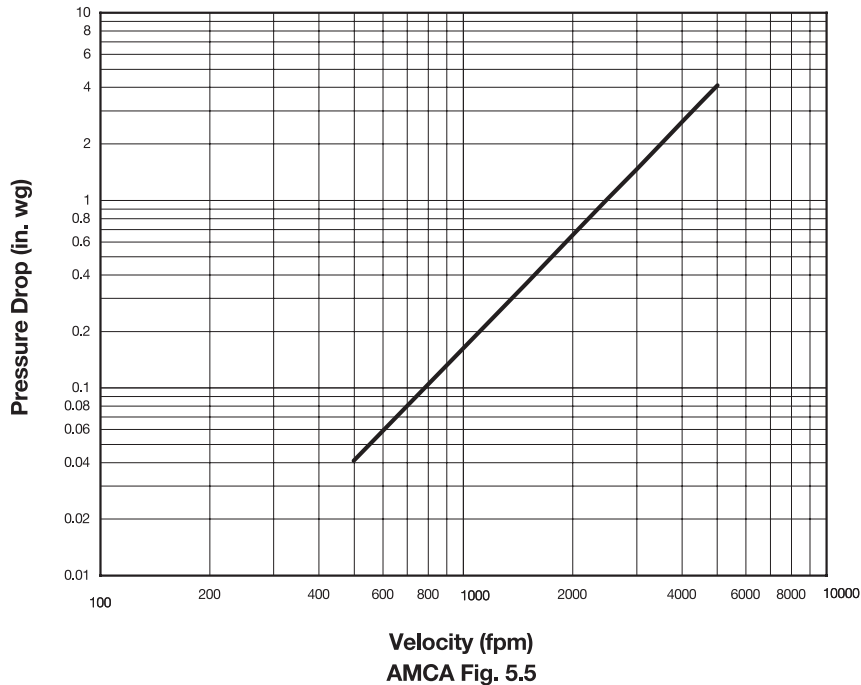

Fig. 5.5

Pressure Drop

36 in. x 36 in. (914mm x 914mm) Damper



Model HTOD-330 and HTOD-331 Difference

HTOD-330

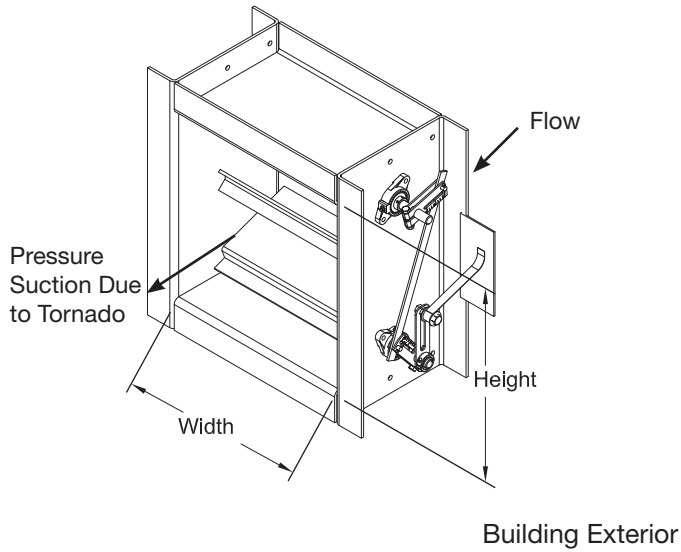

HTOD-331

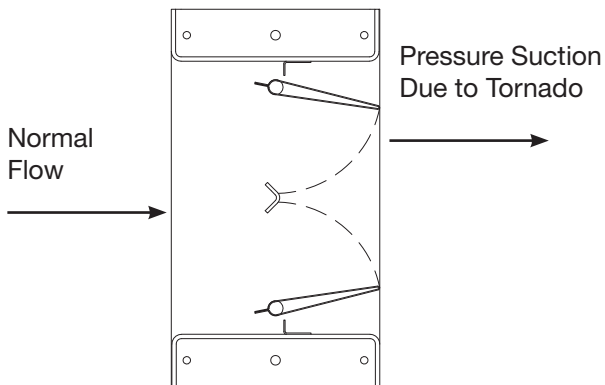
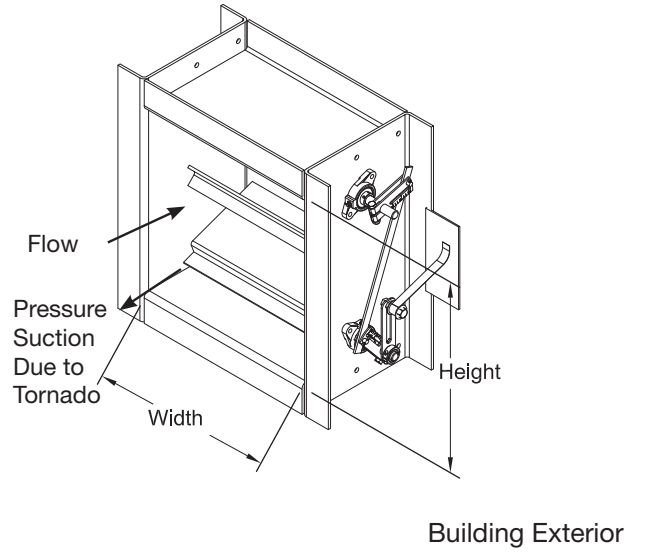

Model HTOD-330

This model closes in the same direction as normal flow.

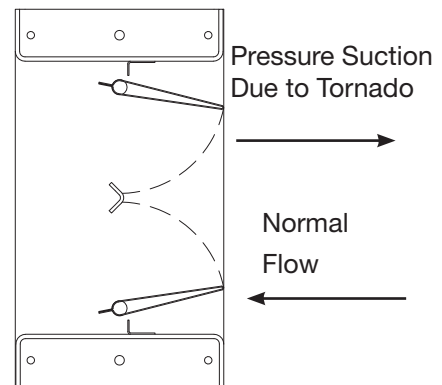

Model HTOD-331

This model closes in the opposite direction as normal flow.

Mounting Holes

Bolt holes are available as an option. The standard pattern is 7/16 in. (11mm) diameter holes (M dimension) spaced 6 in. (152mm) on center (L dimension). Custom bolt hole patterns are available. Contact factory for the limitations.

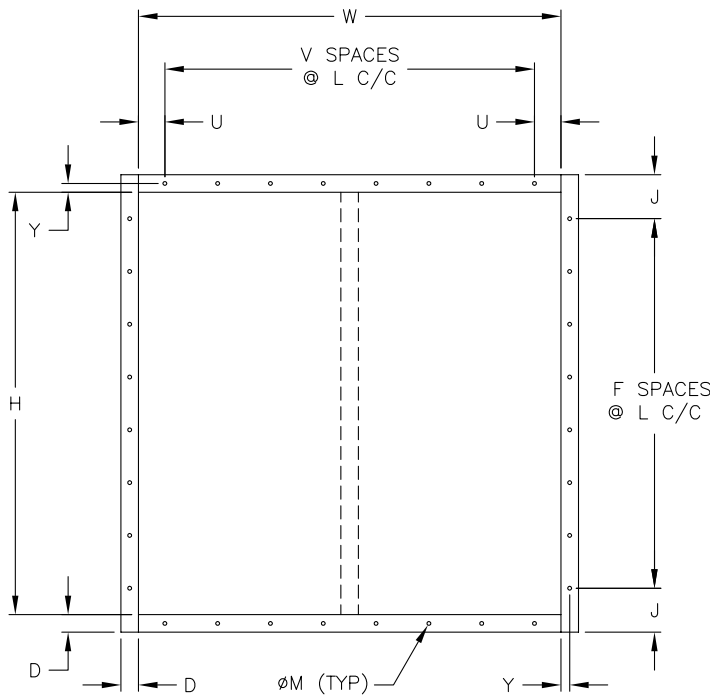

Standard Mounting Hole Pattern
Typical for single or double wide panel

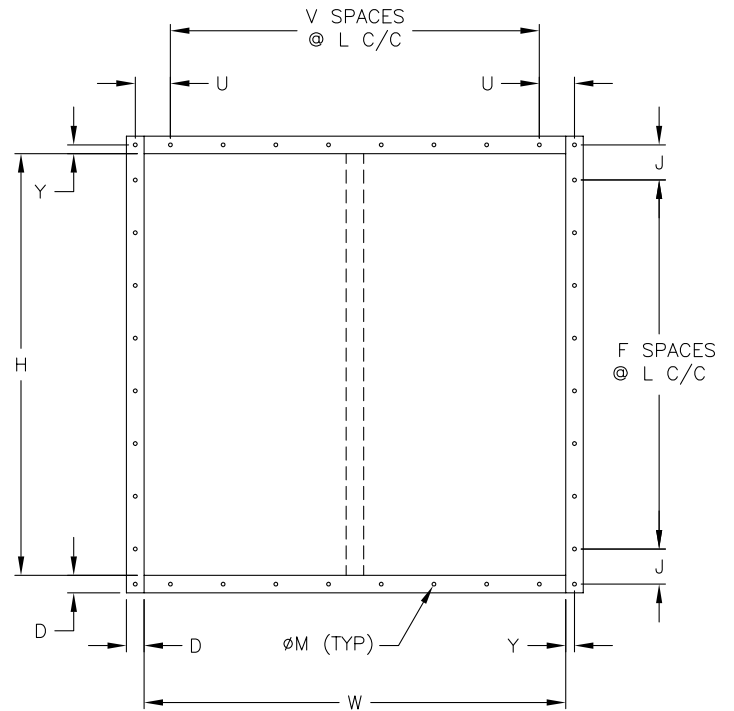

Standard Mounting Hole Pattern with Corner Holes
Typical for single or double wide panel

Links



[INSTALLATION](#)



[CATALOG](#)



[HEAVY DUTY
SELECTION GUIDE](#)



[SELECTION GUIDE](#)



[WARRANTY](#)