

Application

The ICD-45 is a low leakage thermally insulated damper with extruded airfoil blades. ICD-45 features thermally broken frame and blade will minimize the transfer of thermal energy and reduces condensation. It's also IECC (International Energy Conservation Code) compliant with a leakage rating of 3 cfm/ft² @ 1 in. wg (55 cmh/m² @ .25 kPa) or less.

The new quick connect frame allows easy connection to ductwork.

Note regarding UV lights:

The dampers should not be mounted or stored in direct line of sight to UV lights.

Ratings

Pressure

Up to 8 in. wg (2 kPa) pressure differential

Velocity

Up to 4,000 fpm (20.3 m/s)

Leakage

Class 1A @ 1 in. wg at -40°F (Class 1A @ .25 kPa at -40°C)
Class 1 @ 4 in. wg at -40°F (Class 1 @ 4 in. wg at -40°C)

Temperature

-70°F to 200°F (-56°C to 93°C)



*W&H dimension furnished approximately 1/4 in. (6 mm) undersize.

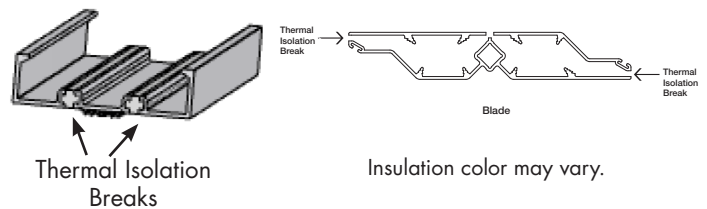

Construction

	Standard	Optional
Frame Material	Aluminium, thermally broken (6063T5)	
Frame Thickness	.125 in. (3.2 mm)	
Frame Type	5 in. x 1 in. (127 mm x 25mm) Quick Connect	Single flange, Reverse flange, Channel
Blade Action	Opposed	Parallel
Blade Material	Extruded aluminium (6063T5)	
Blade Type	Insulated thermally broken airfoil	
Linkage	Plated steel out of airstream	316SS
Axle Bearings	Dual bearing with acetal inner sleeve, flanged outer bearing	
Axle Material	1/2 Inch (13 mm) Plated Steel	316SS
Blade Seals	EPDM	Silicone
Jamb Seals	Silicone	

Size Limitations

in. (mm) W x H		Frame Type			
		Channel, Single or Reverse Flange		Quick Connect	
Blade Action		Parallel	Opposed	Parallel	Opposed
Min. Size	Internal Mount	8 x 8 (203 x 203)	8 x 8 (203 x 203)	-	
	External Mount	8 x 7 (203 x 178)	8 x 7 (203 x 178)	8 x 6 (203 x 152)	8 x 6 (203 x 152)
Max. Size	Single Section	60 in. W x 78 in. H (1524 x 1981)		60 in. W x 76 in. H (1524 x 1930)	
	Multi-Section	180 in. W x 156 in. H (4572 x 3962)		96 in. W x 152 in. H (2438 x 3861)	

Actuator Sizing:

- Factory supplied actuator are sized for a full-open velocity of 1500 fpm (7 m/s) and fully-closed differential pressure of 2 in. wg (.5 kPa)
- Actuators supplied in the field for applications at velocities of 1500 fpm (7 m/s) or less and 2 in. wg of pressure or less shall use the following guidelines:
 - Opposed blade dampers: 7 in-lb per square foot of damper area with a minimum of 60 in-lb
 - Parallel blade dampers: 9 in-lb per square foot of damper area with a minimum of 60 in-lb
- Contact factory for actuator sizing on applications exceeding those limits

Options and Accessories

- Actuator: bracket only, manual quadrant, variety of 24V, 120V, actuators
- Actuator mounting; external and external kit
- Clean wrap
- NEMA enclosures
- 120V to 24V Transformer
- Multi-Voltage Transformer

Frame/Flange Options

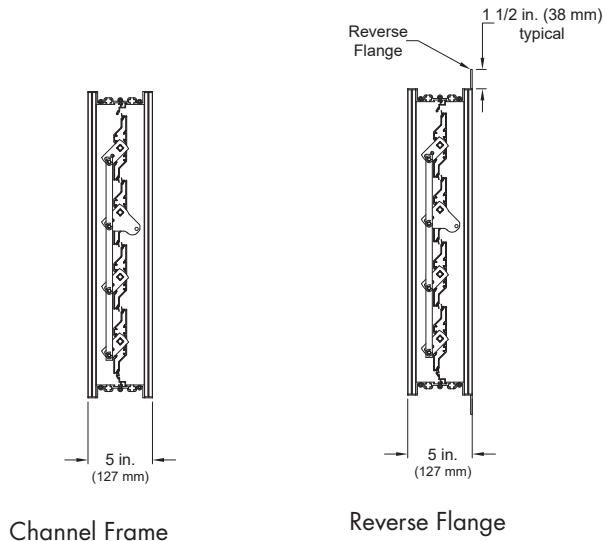

Quick Connect

Note: When ordering the Quick Connect Frame, size is based on duct size (or inside dimension of the damper frame). Quick Connect frame is actual size.

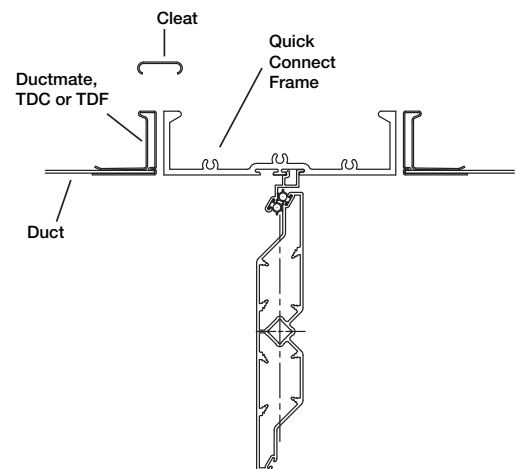
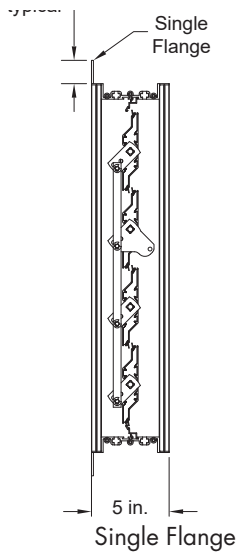
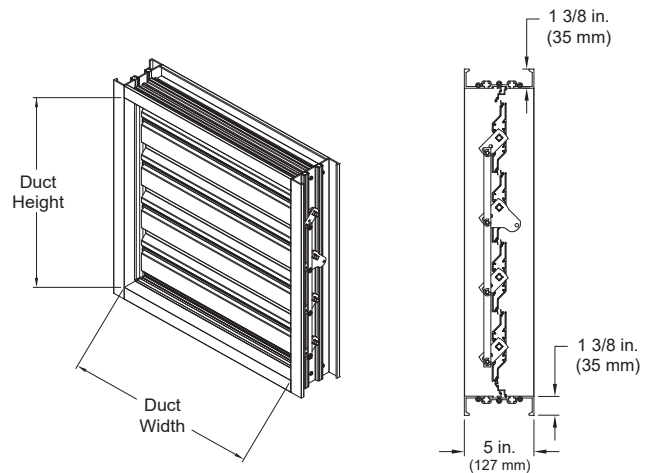

* Width and height is based on outside dimension. W & H dimensions furnished approximately 1/4 in. (6 mm) undersize.

AMCA Pressure Drop

AMCA 5.2

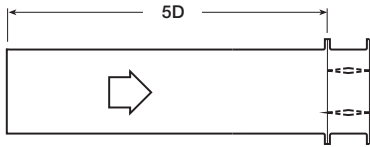

12 x 12 (305 mm x 305 mm)	
Velocity (fpm)	Pressure Drop (in. wg)
500	.03
1000	.11
1500	.25
2000	.45
2500	.71
3000	1.03
3500	1.40
4000	1.83

24 x 24 (610 mm x 610 mm)	
Velocity (fpm)	Pressure Drop (in. wg)
500	.02
1000	.08
1500	.19
2000	.34
2500	.53
3000	.77
3500	1.05
4000	1.37

36 x 36 (914 mm x 914 mm)	
Velocity (fpm)	Pressure Drop (in. wg)
500	.01
1000	.05
1500	.11
2000	.21
2500	.33
3000	.47
3500	.64
4000	.84

12 x 48 (305 mm x 1219 mm)	
Velocity (fpm)	Pressure Drop (in. wg)
500	.01
1000	.06
1500	.14
2000	.25
2500	.40
3000	.57
3500	.78
4000	1.02

48 x 12 (1219 mm x 305 mm)	
Velocity (fpm)	Pressure Drop (in. wg)
500	.03
1000	.14
1500	.32
2000	.57
2500	.89
3000	1.29
3500	1.76
4000	2.30

AMCA 5.3

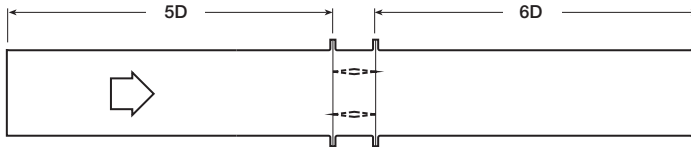

12 x 12 (305 mm x 305 mm)	
Velocity (fpm)	Pressure Drop (in. wg)
500	.01
1000	.04
1500	.09
2000	.17
2500	.26
3000	.38
3500	.52
4000	.67

24 x 24 (610 mm x 610 mm)	
Velocity (fpm)	Pressure Drop (in. wg)
500	.01
1000	.03
1500	.08
2000	.14
2500	.22
3000	.32
3500	.43
4000	.57

36 x 36 (914 mm x 914 mm)	
Velocity (fpm)	Pressure Drop (in. wg)
500	.01
1000	.02
1500	.04
2000	.08
2500	.12
3000	.18
3500	.24
4000	.32

12 x 48 (305 mm x 1219 mm)	
Velocity (fpm)	Pressure Drop (in. wg)
500	.01
1000	.02
1500	.06
2000	.10
2500	.17
3000	.24
3500	.33
4000	.43

48 x 12 (1219 mm x 305 mm)	
Velocity (fpm)	Pressure Drop (in. wg)
500	.01
1000	.06
1500	.14
2000	.25
2500	.40
3000	.58
3500	.79
4000	1.03

AMCA 5.5

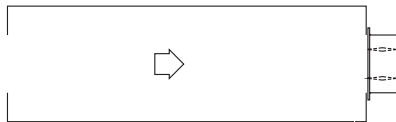

12 x 12 (305 mm x 305 mm)	
Velocity (fpm)	Pressure Drop (in. wg)
500	.05
1000	.23
1500	.52
2000	.93
2500	1.44
3000	2.08
3500	2.83
4000	3.70

24 x 24 (610 mm x 610 mm)	
Velocity (fpm)	Pressure Drop (in. wg)
500	.05
1000	.21
1500	.47
2000	.84
2500	1.32
3000	1.90
3500	2.59
4000	3.39

36 x 36 (914 mm x 914 mm)	
Velocity (fpm)	Pressure Drop (in. wg)
500	.04
1000	.14
1500	.33
2000	.58
2500	.91
3000	1.31
3500	1.79
4000	2.34

12 x 48 (305 mm x 1219 mm)	
Velocity (fpm)	Pressure Drop (in. wg)
500	.04
1000	.18
1500	.42
2000	.74
2500	1.16
3000	1.68
3500	2.28
4000	2.98

48 x 12 (1219 mm x 305 mm)	
Velocity (fpm)	Pressure Drop (in. wg)
500	.05
1000	.22
1500	.51
2000	.90
2500	1.41
3000	2.04
3500	2.78
4000	3.70

Leakage

Leakage Data

Air leakage is based on operation between 32°F (0°C) and 120°F (49°C).

Tested for leakage in accordance with ANSI/AMCA Standard 500-D, Figure 5.5.

Tested for air performance in accordance with ANSI/AMCA Standard 500-D, Figures 5.2, 5.3 and 5.5.

Torque

Data are based on a torque of 7.0 in. lb./ft² (0.79 N·m) with a minimum of 30 in. lb (3.4 N·m) applied to close and seat the damper during the test.

ICD-45	Leakage Class*			
	1 in. wg (0.25 kPa)	4 in. wg (1 kPa)	8 in. wg (2 kPa)	10 in. wg (2.5 kPa)
Maximum Damper Width				
60 in. (1524mm)	1A	1	1	1

*Leakage Class Definitions

The maximum allowable leakage is defined by AMCA as the following:

- Leakage Class 1A - 3 cfm/ft² @ 1 in. wg (class 1A is only defined at 1 in. wg).
- Leakage Class 1
 - 4 cfm/ft² @ 1 in. wg
 - 8 cfm/ft² @ 4 in. wg
 - 11 cfm/ft² @ 8 in. wg
 - 12.6 cfm/ft² @ 10 in. wg

Energy Efficiency Performance

Greenheck Model ICD-45 has a Thermal Efficiency Ratio of 941%.

A damper's Thermal Efficiency Ratio (E) is a comparison of the thermal performance of the tested damper with that of a standard reference damper, which is a 3V blade damper with blade and jamb seals. A damper with the same thermal efficiency as the reference damper would have an E of 0%. A damper that is twice as efficient as the reference damper would have an E of 100%.

Test Information

Testing was conducted on a 36"x36" sample in AMCA 500-D figure 5.10 per AMCA standard 500-D's Thermal Efficiency test.

Torque

Data are based on a torque of 7.0 in. lb./ft² (0.79 N·m) with a minimum of 30 in. lb (3.4 N·m) applied to close and seat the damper during the test.

Plenum Wall Installation

There are applications that require mounting an ICD-45 into a plenum wall. This illustration depicts how to mount an ICD-45 into a plenum wall.

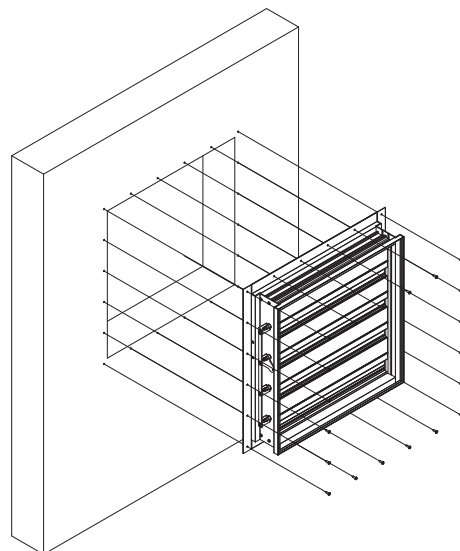

Multi-Section Dampers

Dampers larger than the maximum single section size, will be made up of a multiple of equal size sections. Multiple section dampers can be jackshafed together so that all sections operate together as shown below.

NOTE: Dampers larger than 60 in. x78 in. (1524mm x 1981mm) are not intended to be structurally self supporting. Additional horizontal bracing is recommended to support the weight of the damper and vertical bracing should be installed as required to hold against system pressure.

Refer to IOM document #483516 for structural support requirements on multi-section assemblies.

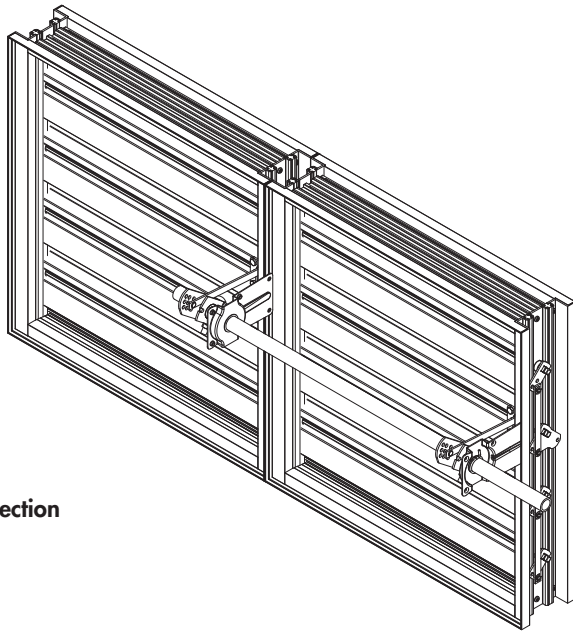

Two section

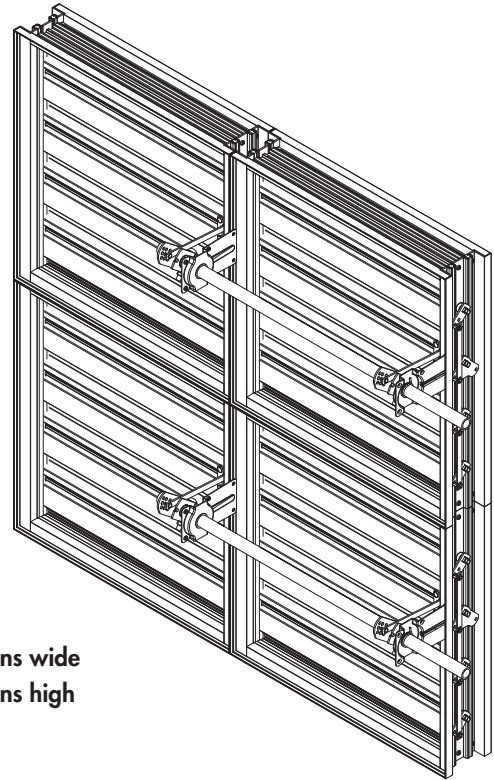

Two sections wide
Two sections high

Document Links



[INSTALLATION](#)



[CATALOG](#)



[SELECTION GUIDE](#)



[WARRANTY](#)