

Stationary Louver Drainable Blade

Application and Design

VASD-2 is a weather louver designed to protect air intake and exhaust openings in building exterior walls. Design incorporates a drainable head member and stationary horizontal blades to channel water to the jambs which guides the water through vertical downspouts for escape at the sill. The VASD-2 is an extremely efficient louver tested in accordance with AMCA 500-L air performance and water penetration enabling designers to select and apply with confidence.

Standard Construction

- Frame** Heavy gauge extruded 6063-T5 aluminum, 2 in. x 0.063 in. nominal wall thickness
- Blades** Drainable design, heavy gauge extruded 6063-T5 aluminum, 0.063 in. nominal wall thickness, positioned at 45° angles on approximately 3 in. centers
- Construction** . . . Mechanically fastened
- Birdscreen** 3/4 in. x 0.051 in. flattened expanded aluminum in removable frame, inside mount (rear)
- Finish** Mill
- Minimum Size** . . 6 in. W x 6 in. H
- Maximum Single Section Size** . . . 120 in. W or 120 in. H (limited to 70 ft. sq.)

Options (at additional cost)

- A variety of bird and insect screens
- Blank off panel
- Clip angles
- Extended sill
- Filter rack
- Flanged frame
- Glazing adaptor
- Hinged frame
- Security bars
- Welded construction
- A variety of architectural finishes including:
 - Clear anodize
 - Integral color anodize
 - Baked enamel paint
 - Kynar paint

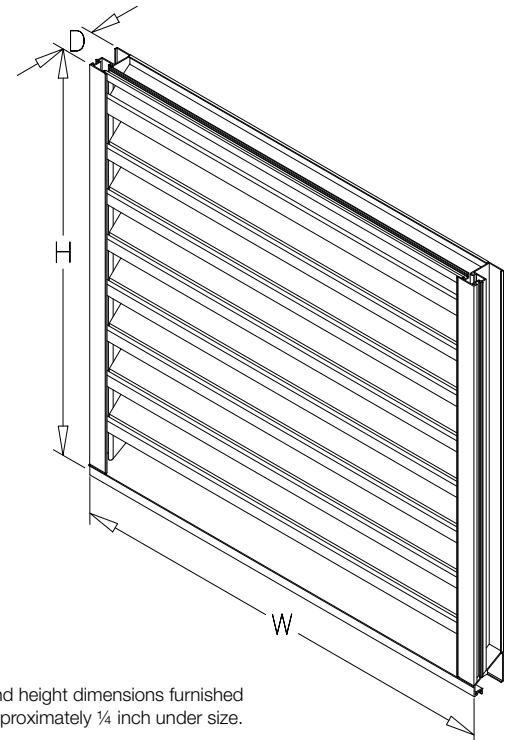
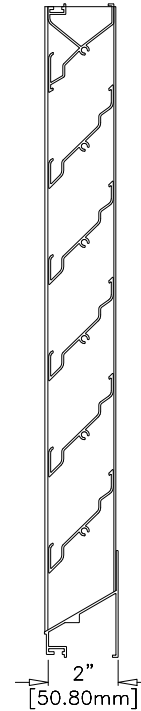

*Width and height dimensions furnished approximately 1/4 inch under size.

PERFORMANCE DATA

VASD-2

Aluminum Stationary
Drainable Blade

Free Area Chart (Sq. ft.)

Height in Inches	Width in Inches																			
	6	12	18	24	30	36	42	48	54	60	66	72	78	84	90	96	102	108	114	120
6	0.02	0.05	0.09	0.12	0.16	0.19	0.23	0.26	0.29	0.32	0.36	0.39	0.43	0.46	0.50	0.53	0.56	0.59	0.63	0.66
12	0.08	0.22	0.37	0.51	0.66	0.80	0.95	1.09	1.02	1.35	1.49	1.64	1.78	1.93	2.07	2.22	2.33	2.47	2.62	2.76
18	0.14	0.41	0.67	0.94	1.20	1.47	1.74	2.00	2.20	2.47	2.73	3.00	3.26	3.53	3.79	4.06	4.26	4.52	4.79	5.05
24	0.20	0.58	0.95	1.33	1.70	2.07	2.45	2.82	3.10	3.48	3.85	4.22	4.60	4.97	5.35	5.72	6.00	6.38	6.75	7.12
30	0.26	0.74	1.22	1.70	2.18	2.66	3.14	3.62	3.98	4.46	4.94	5.42	5.90	6.38	6.86	7.35	7.71	8.19	8.67	9.15
36	0.31	0.88	1.45	2.02	2.59	3.16	3.73	4.30	4.72	5.29	5.86	6.43	7.00	18.27	8.14	8.71	9.14	9.71	10.28	10.85
42	0.37	1.04	1.72	2.39	3.07	3.75	4.42	5.10	5.60	6.28	6.96	7.63	8.31	8.98	9.66	10.34	10.84	11.52	12.20	12.87
48	0.43	1.23	2.02	2.82	3.62	4.42	5.21	6.01	6.61	7.40	8.20	9.00	9.79	10.59	11.39	12.18	12.78	13.58	14.37	15.17
54	0.49	1.40	2.30	3.21	4.12	5.02	5.93	6.84	7.52	8.42	9.33	10.24	11.14	12.05	12.96	13.86	14.54	15.45	16.36	17.26
60	0.55	1.56	2.57	3.59	4.60	5.61	6.63	7.64	8.40	9.41	10.42	11.44	12.45	13.46	14.48	15.49	16.25	17.26	18.27	19.29
66	0.61	1.73	2.85	3.89	5.10	6.22	7.35	8.47	9.31	10.44	11.56	12.68	13.81	14.93	16.05	17.18	18.02	19.14	20.27	21.39
72	0.65	1.86	3.07	4.28	5.49	6.70	7.91	9.11	10.02	11.23	12.44	13.65	14.86	16.06	17.27	18.48	19.39	20.60	21.80	23.01
78	0.71	2.03	3.35	4.67	5.99	7.31	8.63	9.95	10.94	12.25	13.57	14.89	16.21	17.53	18.85	20.17	21.16	22.48	23.80	25.11
84	0.78	2.22	3.66	5.10	6.54	7.98	9.41	10.85	11.93	13.37	14.81	16.25	17.69	19.13	20.57	22.01	23.09	24.53	25.96	27.40
90	0.84	2.39	3.93	5.48	7.03	8.58	10.13	11.67	12.84	14.38	15.93	17.48	19.03	20.58	22.12	23.67	24.83	26.38	27.93	29.48
96	0.90	2.55	4.20	5.86	7.51	9.17	10.82	12.48	13.72	15.37	17.02	18.68	20.33	21.99	23.64	25.30	26.54	28.19	29.84	31.50
102	0.94	2.69	4.43	6.18	7.92	9.66	11.41	13.15	14.46	16.20	17.94	19.69	21.43	23.18	24.92	26.66	27.97	29.71	31.64	33.20
108	1.00	2.85	4.70	6.55	8.40	10.25	12.10	13.95	15.34	17.19	19.04	20.89	22.74	24.59	26.44	28.29	29.67	31.52	33.37	35.22
114	1.07	3.04	5.01	6.98	8.95	10.92	12.89	14.69	16.34	18.31	20.28	22.25	24.22	26.19	28.14	30.13	31.61	33.58	35.55	37.52
120	1.13	3.21	5.29	7.37	9.45	11.53	13.61	15.69	17.25	19.33	21.41	23.49	25.57	27.65	29.73	31.81	33.37	35.45	37.53	39.61

Airflow Resistance (Standard Air - .075 lb/ft³)

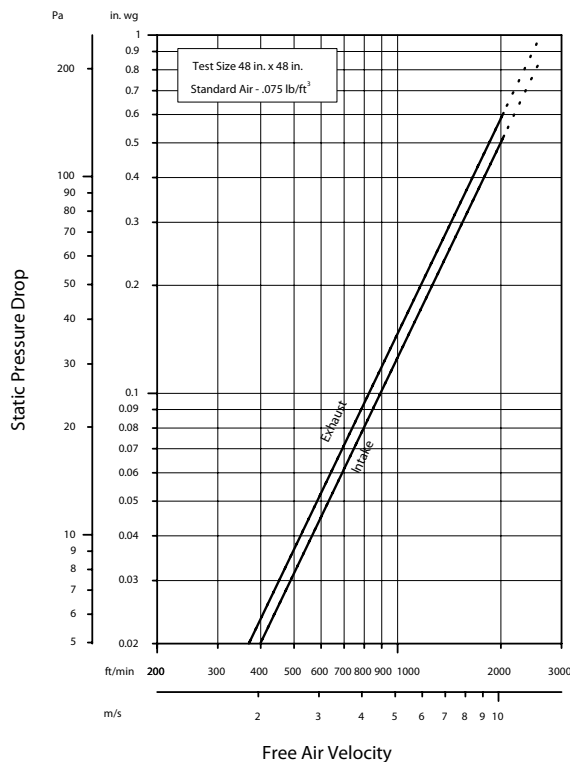

Model VASD-2 resistance to airflow (pressure drop) varies depending on louver application (air intake or air exhaust). Free area velocities (shown) are higher than average velocity through the overall louver size. See louver selection information.

Water Penetration (Standard Air - .075 lb/ft³)

Test size 48 in. x 48 in. Test duration of 15 min.

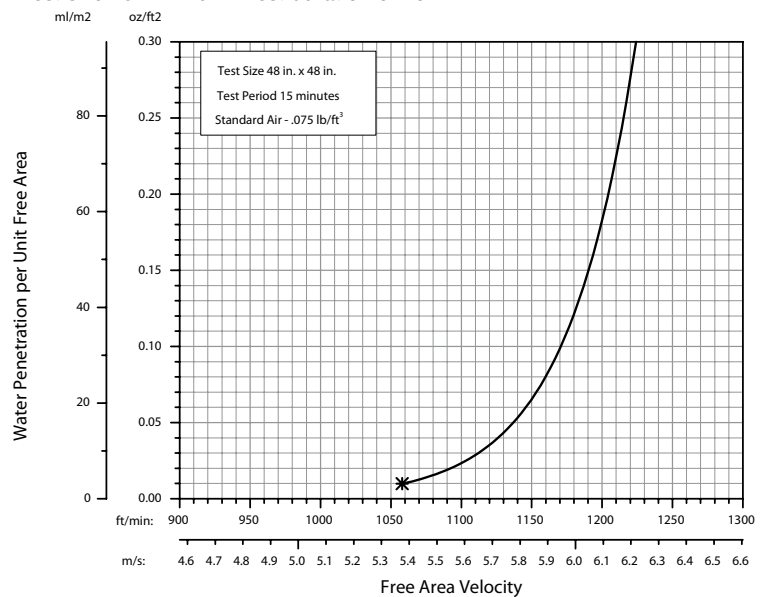

The AMCA Water Penetration Test provides a method for comparing various louver models and designs as to their efficiency in resisting the penetration of rainfall under specific laboratory test conditions. The beginning point of water penetration is defined as that velocity where the water penetration curve projects through .01 oz. of water (penetration) per sq. ft. of louver free area. ***The beginning point of water penetration for Model VASD-2 is 1058 fpm free area velocity.** These performance ratings do not guarantee a louver to be weather-proof or stormproof and should be used in combination with other factors including good engineering judgement in selecting louvers.



PRODUCT DETAILS

VASD-2

Aluminum Stationary
Drainable Blade

Maximum Size and Installation Information

Maximum single section size for model VASD-2 is 120 in. W x 84 in. H or 84 in. W x 120 in. H (70 sq. ft). Larger openings require field assembly of multiple louver sections to make up the overall opening size. Individual louver sections are designed to withstand a 25 PSF wind load (please consult Venco if the louvers must withstand higher wind-loads). Structural reinforcing members may be required to adequately support and install multiple louver sections within a large opening. Structural reinforcing members along with any associated installation hardware is not provided by Venco unless indicated otherwise by Venco. Options and accessories including, but not limited to, screens, filter racks, louver doors, and blank off panels are not subject to structural analysis unless indicated otherwise by Venco.

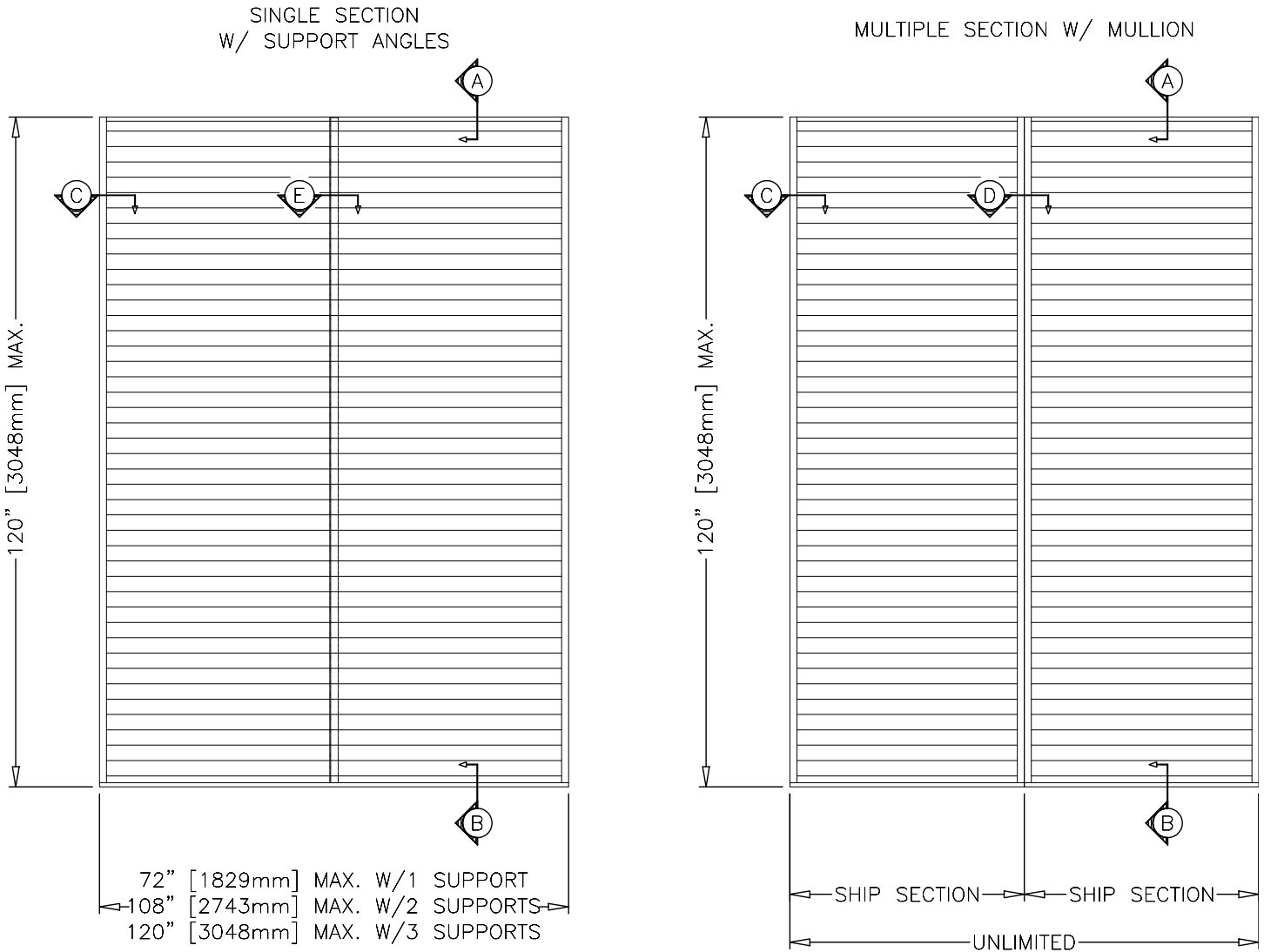

Minimum Single Section Size
6 in. W x 6 in. H

Maximum Single Section Size
70 ft. sq.

PRODUCT DETAILS

VASD-2

Aluminum Stationary
Drainable Blade

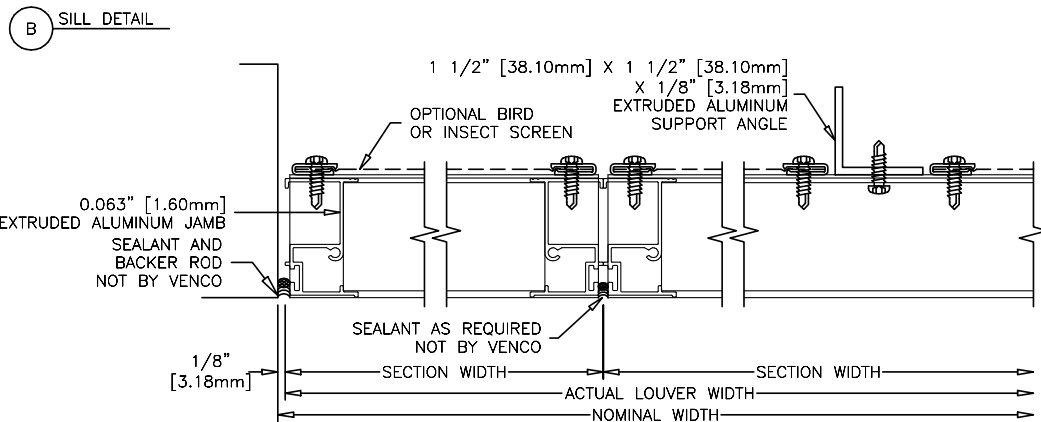
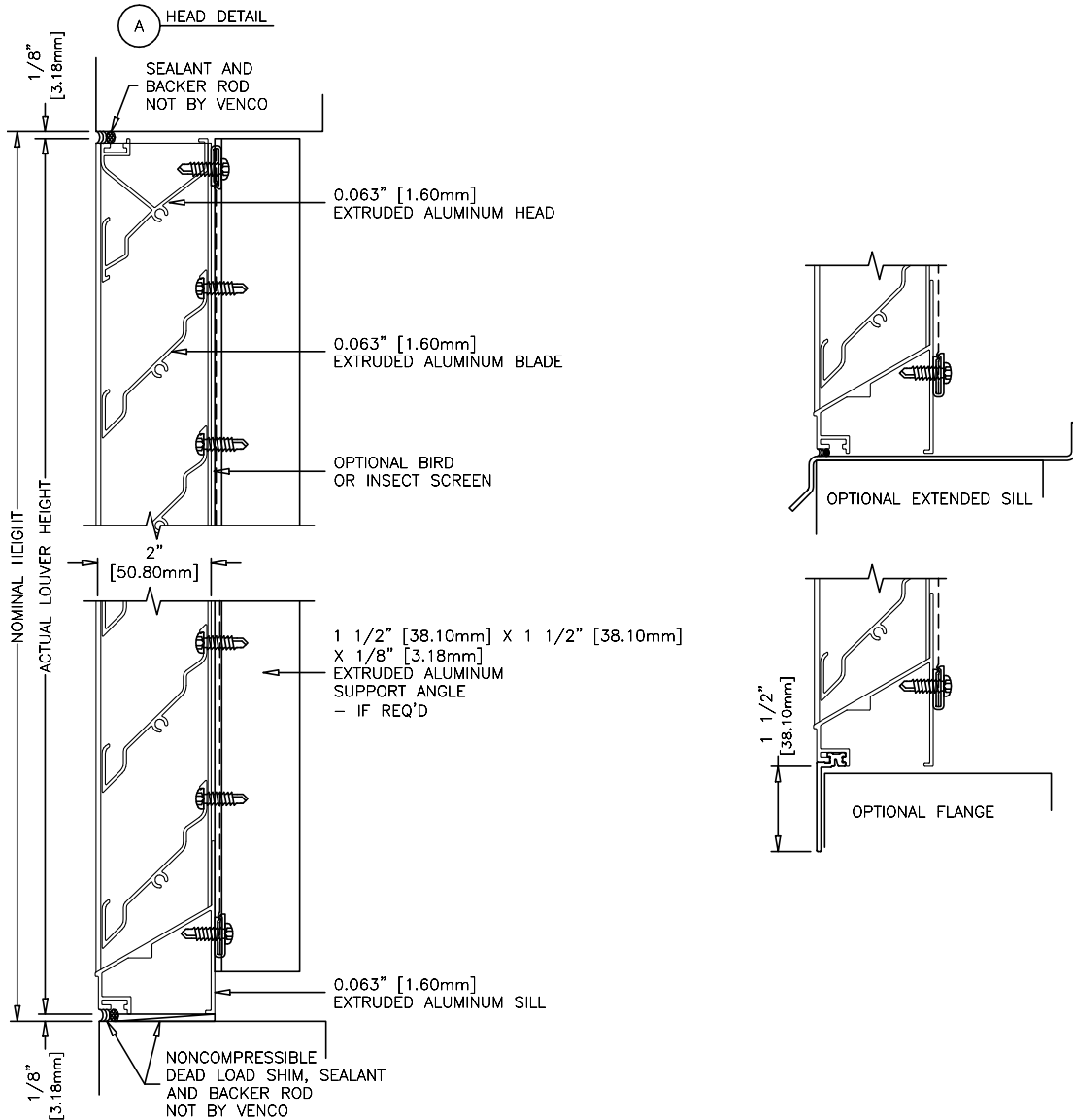

C JAMB DETAIL

D MULLION DETAIL

E SUPPORT DETAIL

OPTION DRAWINGS

VASD-2

Aluminum Stationary Drainable Blade

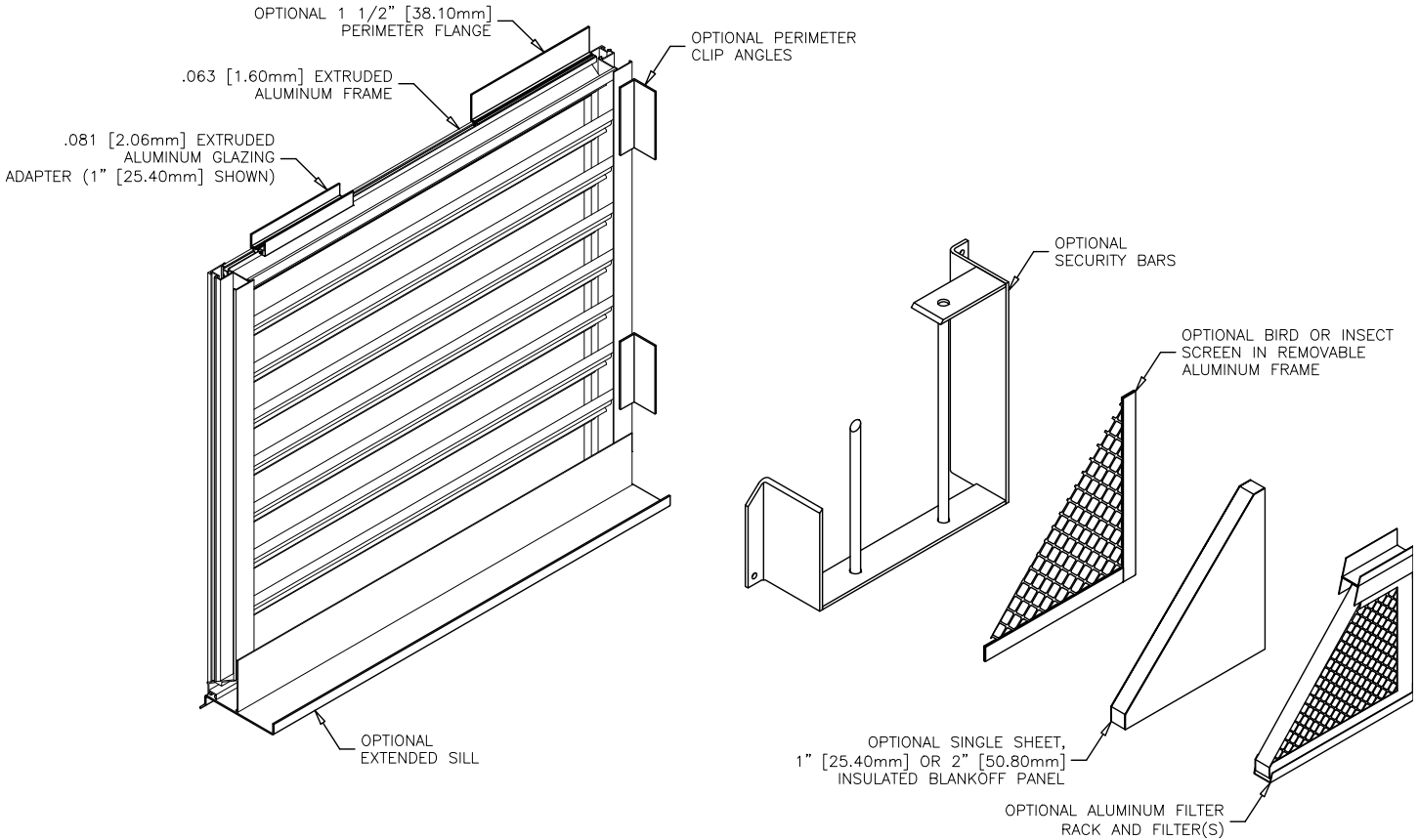

FINISHES

Finish Type	Description/Application	Color Selection	Standard Warranty (Aluminum)
AAMA 2605 100% Fluoropolymer (FEVE) 2-Coat 70% Kynar® (PVDF) 3-Coat 70% Kynar® (PVDF) 4-Coat 70% Kynar® (PVDF)	"Best." The premier finish for extruded aluminum. Tough, long-lasting coating has superior color retention and abrasive properties. Resists chalking, fading, chemical abrasion and weathering.	Standard Colors: Any of the 27 standard colors shown can be furnished in 70% or 50% Kynar®, 100% Fluoropolymer or Baked Enamel.	10 Years (Consult Venco for availability of extended warranty)
AAMA 2604 50% Kynar® / Acroflur®	"Better." Tough, long-lasting coating has excellent color retention and abrasive properties. Resists chalking, fading, chemical abrasion and weathering.	Mica Colors: Venco offers 6 standard Mica colors for 70% Kynar® or 100% Fluoropolymer.	5 Years
AAMA 2603 Baked Enamel	"Good." Provides good adhesion and resistance to weathering, corrosion and chemical stain.	Custom Colors: Custom color matching is available. Consult your Venco representative for cost and/or lead-time implications if a custom color is required.	1 Year
AA-M10C22A42 Integral Color Anodize	"Two-step" anodizing is produced by following the normal anodizing step with a second, colorfast process.	Light, Medium, Dark or Extra Dark Bronze; Champagne; Black	5 years
AA-M10C22A41 Clear Anodize 215 R-1	Clear, colorless and hard oxide aluminum coating that resists weathering and chemical attack.	Clear	5 years
AA-M10C22A31 Clear Anodize 204	Clear, colorless and hard oxide aluminum coating that resists weathering and chemical attack.	Clear	1 Year
Prime Coat	Louvers or architectural products shall be cleaned, pre-treated and receive a prime coat finish suitable for field painting. Venco does not recommend prime coat or field painting of materials.		n/a
Mill	Materials may be supplied in natural aluminum or galvanized steel finish when normal weathering is acceptable and there is no concern for color or color change.		n/a

Finishes meet or exceed AAMA 2605, AAMA 2604, and AAMA 2603 requirements. Please consult Venco for complete information on standard and extended paint warranties. Paint finish warranties are not applicable to steel products.



VASD-2
February 2020
Copyright © 2020 Venco

Venco reserves the right to make product changes without notice.