

Application

The VCD-20 is a control damper used in buildings to regulate the flow air in an HVAC system. They can be used in intake, exhaust, or mixed air application.

Damper Ratings

Velocity

Up to 3000 fpm (15.2 m/s)

Pressure

Up to 5 in. wg (1.2 kPa) - pressure differential

Temperature

-40°F to 250°F (-40°C to 121°C). Consult factory for higher temperatures.

Construction

	Standard	Optional
Frame Material	Galvanized Steel	304SS
Frame Material Thickness	16 ga. (1.5 mm)	12 ga. (2.7 mm)*
Frame Type	5 in. x 1 in. hat channel	Single flange, Reversed flange, Double flange
Blade Material	Galvanized steel	304SS
Blade Thickness	16 ga. (1.5mm)	-
Blade Type	3V	-
Blade Action	Opposed	Parallel
Linkage	Plated steel out of airstream, concealed in jamb	316SS
Axle Bearings	Synthetic	316SS
Axle Material	1/2 in. dia. Plated steel	316SS
Paint Finishes	Mill Finish	Baked Enamel, Hi Pro Polyester, Industrial Epoxy

*When 12 ga. frame is selected and the damper height is less than 17 inches, low profile top and bottom frame members are utilized. These low profile frame members will be made from 16 ga. material.

Size Limitations

W x H	Minimum Size	Maximum Size	
		Single Section	Multiple Section
Inches	6 x 6	48 x 74	Unlimited
mm	152 x 152	1219 x 1880	Unlimited



*W & H dimension furnished approximately 1/4 in. (6mm) undersize.

Blade Operation

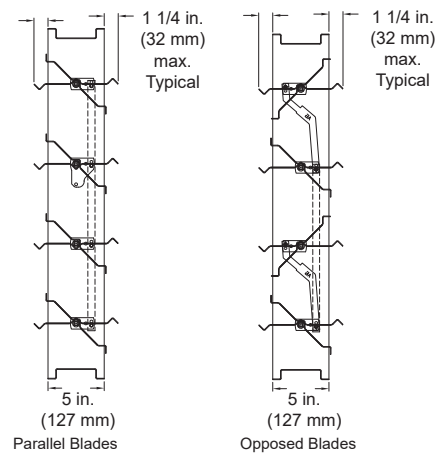

Notes:

- Low profile head and sill are used on sizes less than 17 in. (432mm) high
- Linkage concealed in the frame
- Electric actuator and manual quadrant available. Factory supplied actuators are sized for 1500 fpm (7m/s) and fully closed differential pressure of 2 in. wg (.5 kPa). contact factory for actuator sizing on applications exceeding those limits.
- In applications where airflow could be uneven, such as a discharge fan, it is imperative to verify that at no point the maximum velocity exceeds the damper's cataloged velocity.
- Blades must be horizontal for either horizontal or vertical mount. If you need vertical blades, see VCD-23V model.

Options

- Actuators (24V, 120V, manual, pull chain)
- Actuator mounting (external, external kit (field assembly), internal)
- Flanges
- Multi-section fastening
- NEMA enclosures (3, 4, 4X, 7)
- OCI (open or closed indicator)
- R Transition
- Retaining angles
- Security bars
- Sleeves
- Transformers

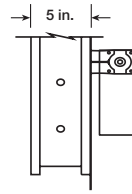

Single Flange

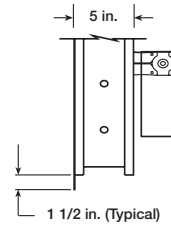

Reversed Flange

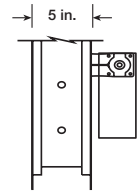

Double Flange

* Shown with optional internally mounted actuator.

Document Links



[INSTALLATION](#)



[CATALOG](#)



[SELECTION GUIDE](#)



[WARRANTY](#)

AMCA Certified Pressure Drop Data

AMCA 5.2

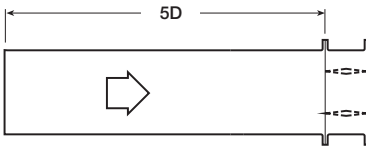

12 in. x 12 in. (305mm x 305mm)

Velocity (fpm)	Pressure Drop (in. wg)
500	0.01
1000	0.05
1500	0.11
2000	0.19
2500	0.29
3000	0.41
3500	0.55
4000	0.72

24 in. x 24 in. (610mm x 610mm)

Velocity (fpm)	Pressure Drop (in. wg)
500	0.01
1000	0.03
1500	0.06
2000	0.10
2500	0.16
3000	0.23
3500	0.30
4000	0.40

36 in. x 36 in. (914mm x 914mm)

Velocity (fpm)	Pressure Drop (in. wg)
500	0.01
1000	0.02
1500	0.05
2000	0.09
2500	0.14
3000	0.19
3500	0.27
4000	0.35

12 in. x 48 in. (305mm x 1219mm)

Velocity (fpm)	Pressure Drop (in. wg)
500	0.01
1000	0.04
1500	0.08
2000	0.15
2500	0.22
3000	0.32
3500	0.43
4000	0.56

48 in. x 12 in. (1219mm x 305mm)

Velocity (fpm)	Pressure Drop (in. wg)
500	0.01
1000	0.03
1500	0.07
2000	0.12
2500	0.18
3000	0.26
3500	0.36
4000	0.47

AMCA 5.3

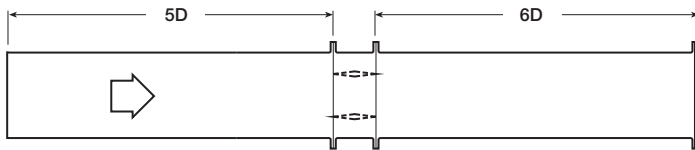

12 in. x 12 in. (305mm x 305mm)

Velocity (fpm)	Pressure Drop (in. wg)
500	0.01
1000	0.03
1500	0.08
2000	0.13
2500	0.20
3000	0.29
3500	0.40
4000	0.51

24 in. x 24 in. (610mm x 610mm)

Velocity (fpm)	Pressure Drop (in. wg)
500	0.01
1000	0.02
1500	0.04
2000	0.07
2500	0.11
3000	0.16
3500	0.21
4000	0.28

36 in. x 36 in. (914mm x 914mm)

Velocity (fpm)	Pressure Drop (in. wg)
500	0.01
1000	0.02
1500	0.03
2000	0.06
2500	0.09
3000	0.13
3500	0.19
4000	0.25

12 in. x 48 in. (305mm x 1219mm)

Velocity (fpm)	Pressure Drop (in. wg)
500	0.01
1000	0.03
1500	0.07
2000	0.12
2500	0.18
3000	0.26
3500	0.36
4000	0.46

48 in. x 12 in. (1219mm x 305mm)

Velocity (fpm)	Pressure Drop (in. wg)
500	0.01
1000	0.03
1500	0.06
2000	0.10
2500	0.16
3000	0.22
3500	0.30
4000	0.39

AMCA 5.5

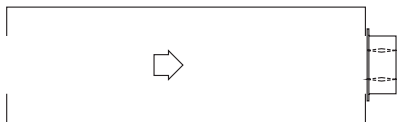

12 in. x 12 in. (305mm x 305mm)

Velocity (fpm)	Pressure Drop (in. wg)
500	0.03
1000	0.13
1500	0.30
2000	0.53
2500	0.82
3000	1.19
3500	1.62
4000	2.10

24 in. x 24 in. (610mm x 610mm)

Velocity (fpm)	Pressure Drop (in. wg)
500	0.03
1000	0.12
1500	0.26
2000	0.47
2500	0.75
3000	1.04
3500	1.41
4000	1.90

36 in. x 36 in. (914mm x 914mm)

Velocity (fpm)	Pressure Drop (in. wg)
500	0.02
1000	0.10
1500	0.22
2000	0.40
2500	0.62
3000	0.90
3500	1.23
4000	1.62

12 in. x 48 in. (305mm x 1219mm)

Velocity (fpm)	Pressure Drop (in. wg)
500	0.03
1000	0.14
1500	0.32
2000	0.57
2500	0.90
3000	1.29
3500	1.76
4000	2.30

48 in. x 12 in. (1219mm x 305mm)

Velocity (fpm)	Pressure Drop (in. wg)
500	0.03
1000	0.12
1500	0.28
2000	0.49
2500	0.77
3000	1.12
3500	1.53
4000	2.01

Leakage Data

Leakage testing was conducted in accordance with AMCA Standard 500-D and is expressed as cfm/ft² of damper face area. All data has been corrected to represent standard air at a density of 0.075 lb/ft³ (1.204 kg/m³).

VCD-20

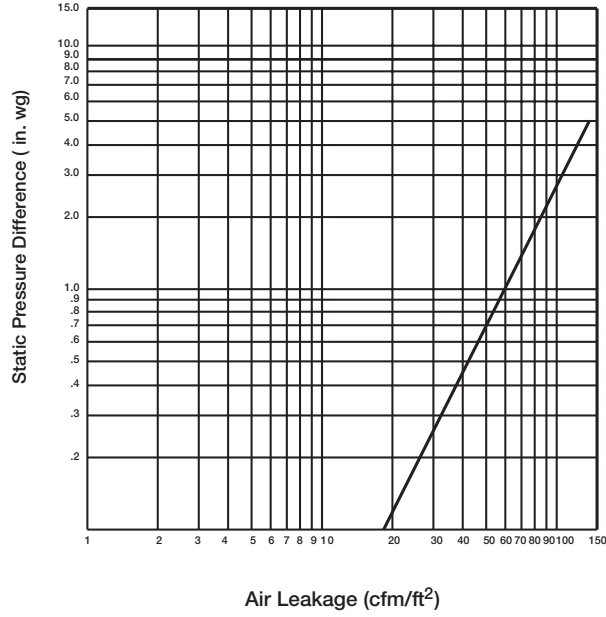

Velocity Limitations

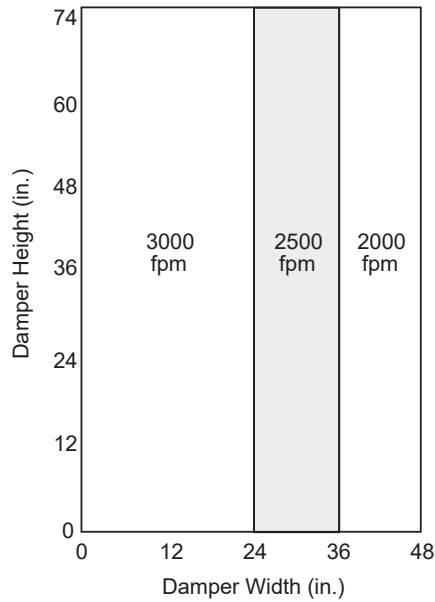

Space Envelopes

On dampers less than 18 in. (457mm) high, actuators may also require clearances above and/or below the damper frame. "B" and "T" dimensions are worst case clearance requirements for some dampers less than 18 in. (457mm) high. All damper sizes under 18 in. (457mm) high do not require these worst case clearances. If space availability above or below the damper is limited, each damper size should be individually evaluated.

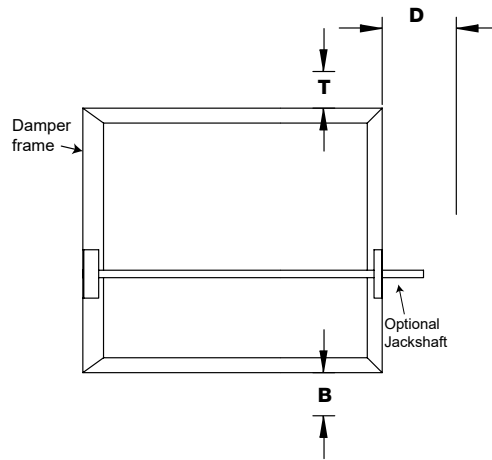

Actuator Type/Model	Height	T	B	D
	Inches	Inches		
AFBUP (-S) and FSNF Series, Belimo MSxx20 Series, Honeywell	≥6 to <10	0	12 ³ / ₄	6 ¹ / ₄
	≥10 to <18	0	2	6 ¹ / ₄
	≥18	0	0	6 ¹ / ₄
FSLF, LF and TFB Series, Belimo	≥6 to <10	0	3 ¹ / ₂	6 ¹ / ₄
	≥10	0	0	6 ¹ / ₄
MSxx04 & MSxx09 Series, Honeywell	≥6 to <9	0	4 ³ / ₄	6 ¹ / ₄
	≥9	0	0	6 ¹ / ₄
MS75xx Series, Honeywell	≥6 to <10	0	12 ³ / ₄	6 ¹ / ₄
	≥10 to <18	0	7	6 ¹ / ₄
	≥18	0	0	6 ¹ / ₄
GRD and GVD Series, Siemens	≥6 to <10	0	12 ³ / ₄	6 ¹ / ₄
	≥10 to <18	0	2	6 ¹ / ₄
	≥18	0	0	6 ¹ / ₄
GJD Series, Siemens	≥6 to <10	0	3 ¹ / ₂	6 ¹ / ₄
	≥10 to <18	0	0	6 ¹ / ₄
	≥18	0	0	6 ¹ / ₄

Actuator Mounting

Actuators may be installed at the factory or shipped loose with the necessary linkage and brackets required for mounting. For more detail information on actuator mounting, click on link below or scan QR code.



[ACTUATOR MOUNTING](#)

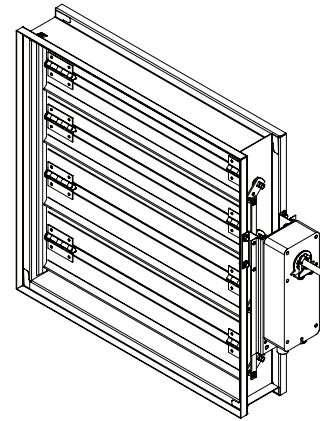

Non-jackshaft external right

Clearance Requirements

This drawing depicts the worst case clearance requirements for an actuator with a jackshaft.

Internal mount only Actuator model	A	B	C
All except - EFB & EFCX Series	7 ¾ in (197 mm)	3 ¾ in (95 mm)	5 ⅜ in (136.5 mm)
EFB & EFCX Series	8 ½ in (216 mm)	6 in (152mm)	8 ½ in (216 mm)

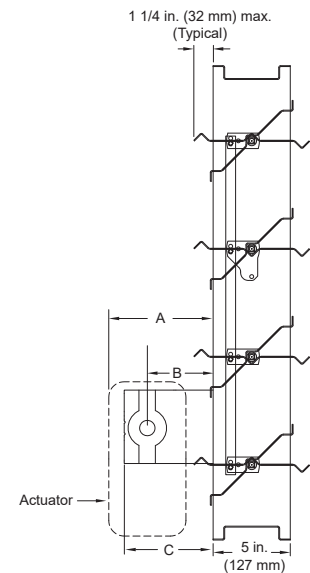

Multi-Section Dampers

Dampers larger than the maximum single section size, will be made up of a multiple of equal size sections. Multiple section dampers can be jackshafed together so that all sections operate together as shown below.

NOTE: Dampers larger than 48 in. x 74 in. (1219mm x 1880mm) are not intended to be structurally self supporting. Refer to IOM document 483509 for structural support requirements on multi-section assemblies.

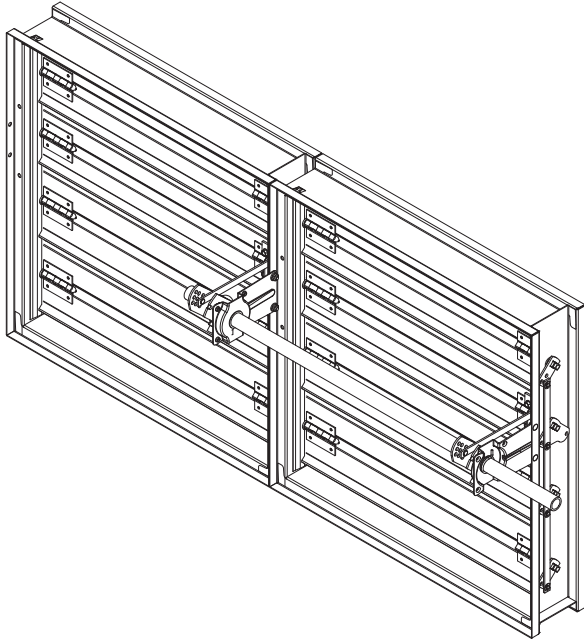

2 section example shows single jackshaft driving multiple sections

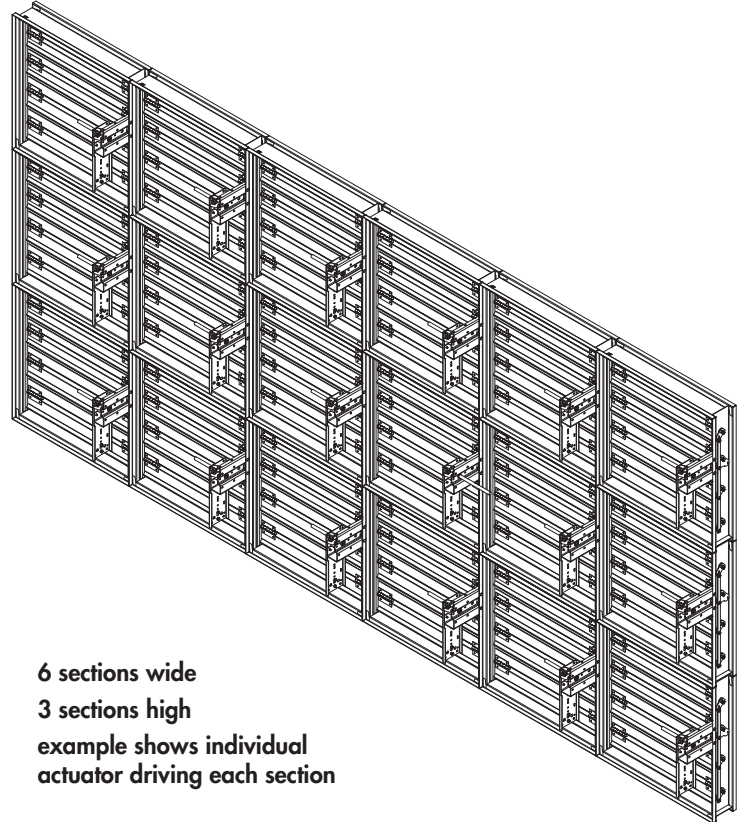

6 sections wide
3 sections high
example shows individual actuator driving each section