

Application

The VCD-23 is a low leakage control damper used in buildings to regulate the flow air in an HVAC system. They can be used in intake, exhaust, or mixed air application.

This model is IECC (International Energy Conservation Code) compliant with a leakage rating of 3 cfm/ft² at 1 in. wg (55 cmh/m² at .25 kPa) or less.

Damper Ratings

Velocity

Up to 3000 fpm (15.2 m/s)

Pressure

Up to 5 in. wg (1.2 kPa) - pressure differential

Leakage

Class 1A at 1 in. wg (0.25 kPa)
Class 1 up to 5 in. wg (1.2 kPa)

Temperature

-40°F to 250°F (-40°C to 121°C). Consult factory for higher temperature



* W&H dimension furnished approximately ¼ in. (6 mm) undersize.

Construction

	Standard	Optional
Frame Material	Galvanized Steel	304SS
Frame Material Thickness	16 ga. (1.5 mm)	12 ga. (2.7 mm)*
Frame Type	5 in. x 1 in. hat channel	Single flange, Reversed flange, Double flange
Blade Material	Galvanized steel	304SS
Blade Thickness	16 ga. (1.5mm)	-
Blade Type	3V	-
Blade Action	Opposed	Parallel
Blade Seals	TPE	Silicone, None**
Linkage	Plated steel out of airstream, concealed in jamb	316SS
Axle Bearings	Synthetic	316SS
Axle Material	½ in. dia. Plated steel	316SS
Jamb Seal	Stainless Steel	-

*When 12 ga. (2.7 mm) frame is selected and the damper height is less than 17 inches (432 mm), low profile top and bottom frame members are utilized. These low profile frame members will be made from 16 ga. (1.5 mm) material.

**AMCA leakage applies when damper is provided with blade seals.

Size Limitations

W x H	Minimum Size	Maximum Size	
		Single Section	Multiple Section
Inches	6 x 6	48 x 74	Unlimited
mm	152 x 152	1219 x 1880	Unlimited

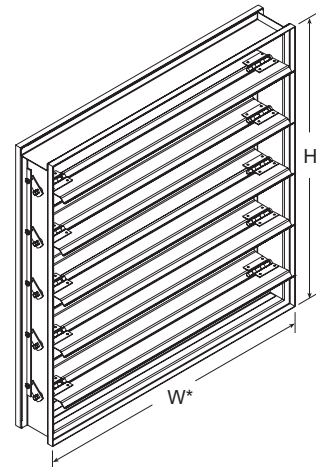

Notes:

- Low profile head and sill are used on sizes less than 17 in. (432mm) high
- Electric actuator and manual quadrant available. Factory supplied actuators are sized for 1500 fpm (7m/s) and fully closed differential pressure of 2 in. wg (.5 kPa). Contact factory for actuator sizing on applications exceeding those limits.
- In applications where airflow could be uneven, such as a discharge fan, it is imperative to verify that at no point the maximum velocity exceeds the damper's cataloged velocity.
- Blades must be horizontal for either horizontal or vertical mount. If you need vertical blades, see VCD-23V model.

Blade Operation

Parallel blade operation - this configuration requires the damper blades to rotate in the same direction, parallel to one another.

Opposed blade operation - adjacent damper blades rotate opposite one another.

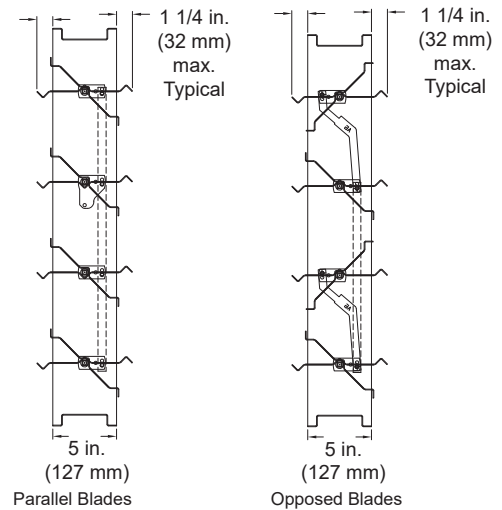

Options

- Actuators (24V, 120V, manual, pull chain)
- Actuator mounting (external, external kit (field assembly), internal)
- Flanges
- Multi-section fastening
- NEMA enclosures (3, 4, 4X, 7)
- OCI (open or closed indicator)
- R Transition
- Retaining angles
- Sleeves
- Transformers

Frame Options

Channel Frame

The channel frame option is designed for in-duct or slip-in installation. Dampers with external actuators can be rotated in the field 180 degrees to change from right hand to left hand drive (not recommended on parallel blade dampers).

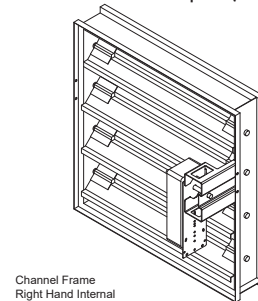

Channel Frame
Right Hand Internal

Reversed Flange

The reversed flange frame option is designed for “flange to wall/ opening” applications. Dampers with external mount actuators must be installed from the interior (cannot be “insert mounted”) to avoid obstructions. Dampers with external actuators can be rotated in the field 180 degrees to change from right hand to left hand drive (not recommended on parallel blade dampers). The flange will be located on the opposite side of the damper frame as the jackshaft/actuator for internal mount actuators.

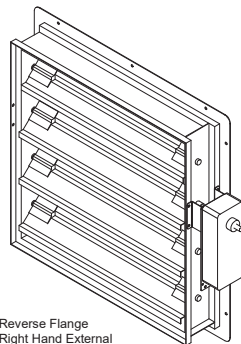

Reverse Flange
Right Hand External

Single Flange

The single flange frame option is designed for “flange to wall/ opening” applications. Dampers with external mount actuators must be installed from the interior (cannot be “insert mounted”) to avoid obstructions. Dampers with external actuators can be rotated in the field 180 degrees to change from right hand to left hand drive (not recommended on parallel blade dampers). The flange will be located on the same side of the damper frame as the jackshaft/actuator for internal mount actuators.

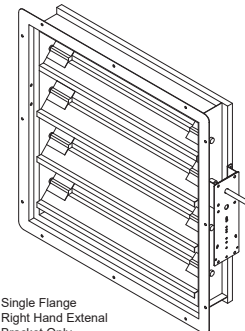

Single Flange
Right Hand External
Bracket Only

Pressure Drop Data

AMCA 5.2

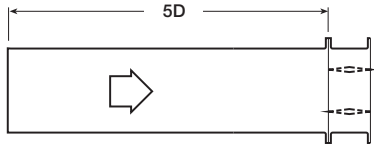

12 in. x 12 in. (305 mm x 305 mm)

Velocity (fpm)	Pressure Drop (in. wg)
500	0.01
1000	0.05
1500	0.11
2000	0.19
2500	0.29
3000	0.41
3500	0.55
4000	0.72

24 in. x 24 in. (610 mm x 610 mm)

Velocity (fpm)	Pressure Drop (in. wg)
500	0.01
1000	0.03
1500	0.06
2000	0.10
2500	0.16
3000	0.23
3500	0.30
4000	0.40

36 in. x 36 in. (914 mm x 914 mm)

Velocity (fpm)	Pressure Drop (in. wg)
500	0.01
1000	0.02
1500	0.05
2000	0.09
2500	0.14
3000	0.19
3500	0.27
4000	0.35

12 in. x 48 in. (305 mm x 1219 mm)

Velocity (fpm)	Pressure Drop (in. wg)
500	0.01
1000	0.04
1500	0.08
2000	0.15
2500	0.22
3000	0.32
3500	0.43
4000	0.56

48 in. x 12 in. (1219 mm x 305 mm)

Velocity (fpm)	Pressure Drop (in. wg)
500	0.01
1000	0.03
1500	0.07
2000	0.12
2500	0.18
3000	0.26
3500	0.36
4000	0.47

AMCA 5.3

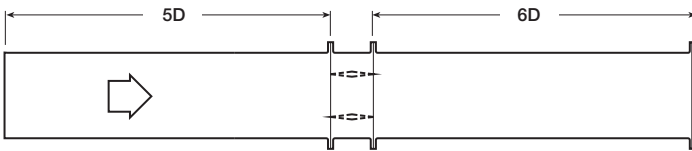

12 in. x 12 in. (305 mm x 305 mm)

Velocity (fpm)	Pressure Drop (in. wg)
500	0.01
1000	0.03
1500	0.08
2000	0.13
2500	0.20
3000	0.29
3500	0.40
4000	0.51

24 in. x 24 in. (610 mm x 610 mm)

Velocity (fpm)	Pressure Drop (in. wg)
500	0.01
1000	0.02
1500	0.04
2000	0.07
2500	0.11
3000	0.16
3500	0.21
4000	0.28

36 in. x 36 in. (914 mm x 914 mm)

Velocity (fpm)	Pressure Drop (in. wg)
500	0.01
1000	0.02
1500	0.03
2000	0.06
2500	0.09
3000	0.13
3500	0.19
4000	0.25

12 in. x 48 in. (305 mm x 1219 mm)

Velocity (fpm)	Pressure Drop (in. wg)
500	0.01
1000	0.03
1500	0.07
2000	0.12
2500	0.18
3000	0.26
3500	0.36
4000	0.46

48 in. x 12 in. (1219 mm x 305 mm)

Velocity (fpm)	Pressure Drop (in. wg)
500	0.01
1000	0.03
1500	0.06
2000	0.10
2500	0.16
3000	0.22
3500	0.30
4000	0.39

AMCA 5.5

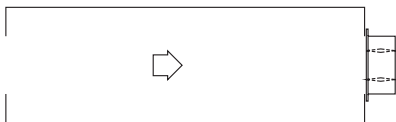

12 in. x 12 in. (305 mm x 305 mm)

Velocity (fpm)	Pressure Drop (in. wg)
500	0.03
1000	0.13
1500	0.30
2000	0.53
2500	0.82
3000	1.19
3500	1.62
4000	2.10

24 in. x 24 in. (610 mm x 610 mm)

Velocity (fpm)	Pressure Drop (in. wg)
500	0.03
1000	0.12
1500	0.26
2000	0.47
2500	0.75
3000	1.04
3500	1.41
4000	1.90

36 in. x 36 in. (914 mm x 914 mm)

Velocity (fpm)	Pressure Drop (in. wg)
500	0.02
1000	0.10
1500	0.22
2000	0.40
2500	0.62
3000	0.90
3500	1.23
4000	1.62

12 in. x 48 in. (305 mm x 1219 mm)

Velocity (fpm)	Pressure Drop (in. wg)
500	0.03
1000	0.14
1500	0.32
2000	0.57
2500	0.90
3000	1.29
3500	1.76
4000	2.30

48 in. x 12 in. (1219 mm x 305 mm)

Velocity (fpm)	Pressure Drop (in. wg)
500	0.03
1000	0.12
1500	0.28
2000	0.49
2500	0.77
3000	1.12
3500	1.53
4000	2.01

Leakage Data

Air leakage is based on operation between 32°F (0°C) and 120°F (49°C).

Tested for leakage in accordance with ANSI/AMCA Standard 500-D, Figure 5.5.

Tested for air performance in accordance with ANSI/AMCA Standard 500-D, Figures 5.2, 5.3 and 5.5.

Torque

Data are based on a torque of 5.0 in. lb./ft² (0.56 N·m) applied to close and seat the damper during the test.

VCD-23	Leakage Class*		
Maximum Damper Width	1 in. wg (0.25 kPa)	4 in. wg (1 kPa)	5 in. wg (1.2 kPa)
48 in. (1219mm)	1A	1	1

*Leakage Class Definitions

The maximum allowable leakage is defined by AMCA as the following:

- Leakage Class 1A - 3 cfm/ft² at 1 in. wg (class 1A is only defined at 1 in. wg).
- Leakage Class 1
 - 4 cfm/ft² at 1 in. wg
 - 8 cfm/ft² at 4 in. wg
 - 11 cfm/ft² at 8 in. wg
 - 12.6 cfm/ft² at 10 in. wg

Velocity and Temperature Limitations

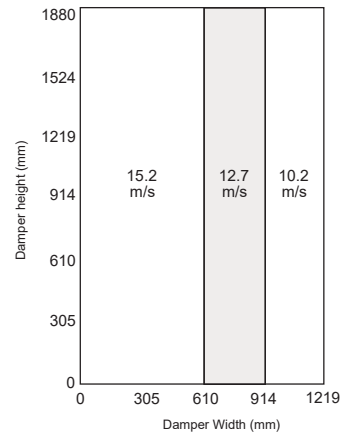
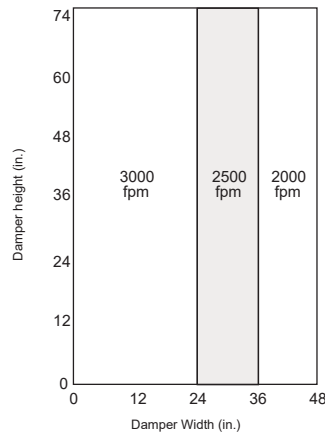

Temperature Limitations

Blade Seal	Temperature Range
TPE	-10°F to 200°F (-23°C to 93°C)
Silicone	-40°F to 250°F (-40°C to 121°C)
No Seal	-40°F to 250°F (-40°C to 121°C)

Space Envelopes

On dampers less than 18 in. (457mm) high, actuators may also require clearances above and/or below the damper frame. “B” and “T” dimensions are worst case clearance requirements for some dampers less than 18 in. (457mm) high. All damper sizes under 18 in. (457mm) high do not require these worst case clearances. If space availability above or below the damper is limited, each damper size should be individually evaluated.

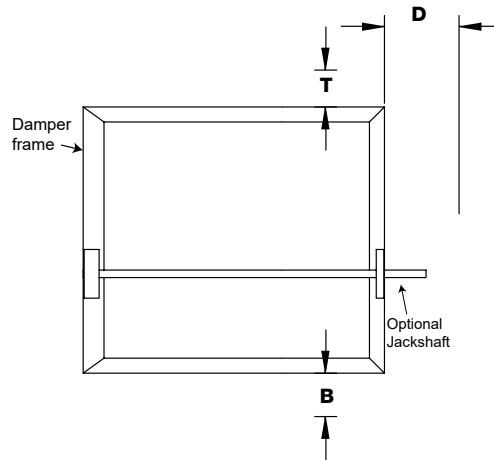

Actuator Type/Model	Height	T	B	D
	Inches		Inches	
AFBUP (-S) and FSNF Series, Belimo MSxx20 Series, Honeywell	≥6 to <10	0	12¾	6¼
	≥10 to <18	0	2	6¼
	≥18	0	0	6¼
FSLF, LF and TFB Series, Belimo	≥6 to <10	0	3½	6¼
	≥10	0	0	6¼
MSxx04 & MSxx09 Series, Honeywell	≥6 to <9	0	4¾	6¼
	≥9	0	0	6¼
MS75xx Series, Honeywell	≥6 to <10	0	12¾	6¼
	≥10 to <18	0	7	6¼
	≥18	0	0	6¼
GRD and GVD Series, Siemens	≥6 to <10	0	12¾	6¼
	≥10 to <18	0	2	6¼
	≥18	0	0	6¼
GJD Series, Siemens	≥6 to <10	0	3½	6¼
	≥10 to <18	0	0	6¼
	≥18	0	0	6¼

Actuator Mounting

Actuators may be installed at the factory or shipped loose with the necessary linkage and brackets required for mounting. For more detail information on actuator mounting, click on link below or scan QR code.



[ACTUATOR MOUNTING](#)

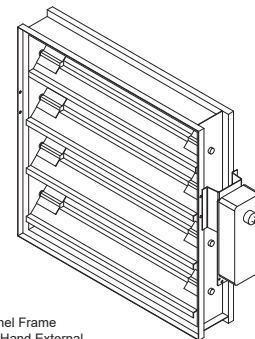

Channel Frame
Right Hand External

Clearance Requirements

This drawing depicts the worst case clearance requirements for an actuator with a jackshaft.

Internal mount only Actuator model	A	B	C
All except - EFB & EFCX Series	7 in (178 mm)	3 ¾ in (95 mm)	6 ¾ in (171 mm)
EFB & EFCX Series	9 in (229 mm)	6 in (152 mm)	9 in (229 mm)

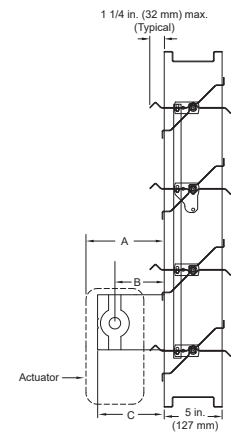

Multi-Section Dampers

Dampers larger than the maximum single section size, will be made up of a multiple of equal size sections. Multiple section dampers can be jackshafted together so that all sections operate together as shown below.

NOTE: Dampers larger than 48 in. x 74 in. (1219mm x 1880mm) are not intended to be structurally self supporting. Refer to IOM document 483509 for structural support requirements on multi-section assemblies.

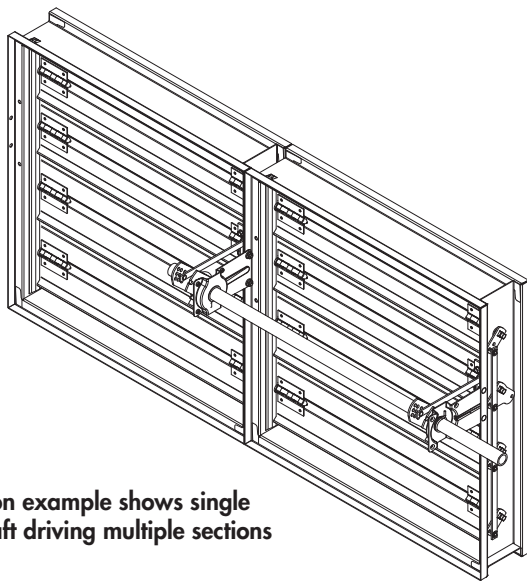

2 section example shows single jackshaft driving multiple sections

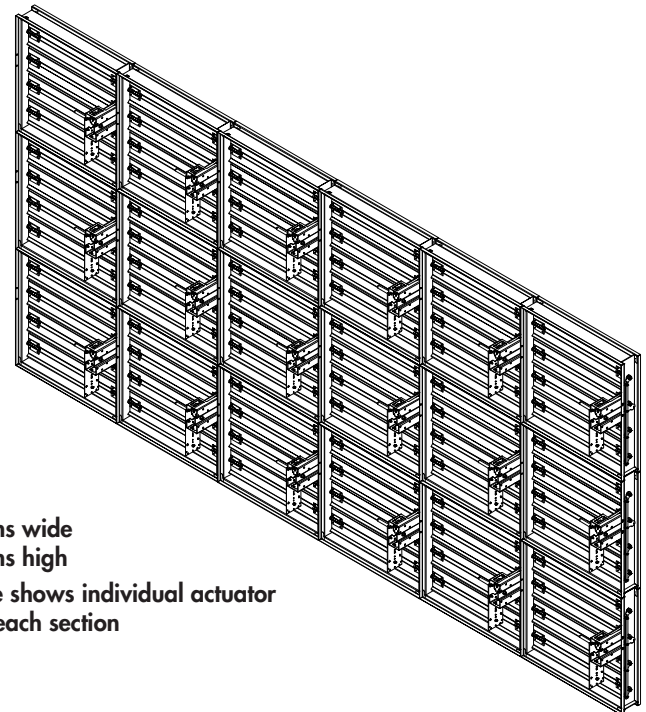

6 sections wide
3 sections high
example shows individual actuator driving each section

Document Links



[INSTALLATION](#)



[SELECTION GUIDE](#)



[CATALOG](#)



[WARRANTY](#)