

Application

The VCD-33 series is a low leakage damper with steel airfoil blades. The airfoil shape reduces pressure drop and turbulence in a HVAC system. The VCD-33 is intended for application in medium to high pressure and velocity systems.

This model is also IECC (International Energy Conservation Code) compliant with a leakage rating of 3 cfm/ft² at 1 in. wg (55 cmh/m² at .25 kPa) or less.

Damper Ratings

Velocity

Up to 4000 fpm (20.3 m/s)

Leakage

Class 1A at 1 in. wg (.25 kPa)

Class 1 at 4 in. - 8 in. wg (1 kPa - 2 kPa)

Pressure

Up to 8 in. wg (2 kPa) pressure differential
For pressures greater than 8 in wg, consult factory.

Temperature

-40°F to 250°F (-40°C to 121°C). Consult factory for higher temperatures.



* W&H dimension furnished approximately 1/4 in. (6mm) undersize.

Size Limitations

W x H	Minimum Size	Maximum Size	
		Single Section	Multiple Section
Inches	6 x 6	60 x 74	Unlimited
mm	152 x 152	1524 x 1880	Unlimited

Construction

	Standard	Optional
Frame Material	Galvanized Steel	304SS
Frame Thickness	16 ga. (1.5 mm)	12 ga. (2.7 mm)*
Frame Type	5 in. x 1 in. (127mm x 25mm) hat channel	Single flange, Reversed flange, Double flange
Blade Material	Galvanized steel	304SS
Blade Thickness	2 skins of 20 ga. (1mm)	-
Blade Type	Airfoil	-
Blade Action	Opposed	Parallel
Linkage	Plated steel out of airstream	316SS
Axle Bearings	Synthetic (acetal)	316SS
Axle Material	Plated steel	316SS
Blade Seals	TPE	Silicone
Jamb Seals	Stainless Steel	-
Paint Finishes	Mill Finish	Baked Enamel, Hi Pro Polyester, Industrial Epoxy

*When 12 ga. frame is selected and the damper height is less than 17 inches, low profile top and bottom frame members are utilized. These low profile frame members will be made from 16 ga. material.

Blade Operation

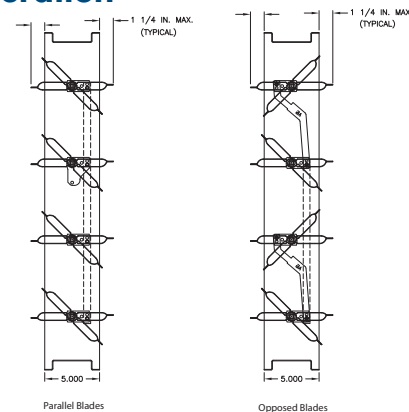

Notes:

- Low profile head and sill are used on sizes less than 17 in. (432mm) high
- Linkage concealed in the frame
- Electric actuator and manual quadrant available. Factory supplied actuators are sized for 1500 fpm (7m/s) and fully closed differential pressure of 2 in. wg (.5 kPa). contact factory for actuator sizing on applications exceeding those limits.
- In applications where airflow could be uneven, such as a discharge fan, it is imperative to verify that at no point the maximum velocity exceeds the damper's cataloged velocity.
- Blades must be horizontal for either horizontal or vertical mount. If you need vertical blades, see VCD-33V model.

Options

- Actuators (24V, 120V, manual, pull chain)
- Actuator mounting (external, external kit (field assembly), internal)
- Flanges
- Multi-section fastening
- NEMA enclosures (3, 4, 4X, 7)
- OCI (open or closed indicator)
- R Transition
- Retaining angles
- Security bars
- Sleeves
- Transformers

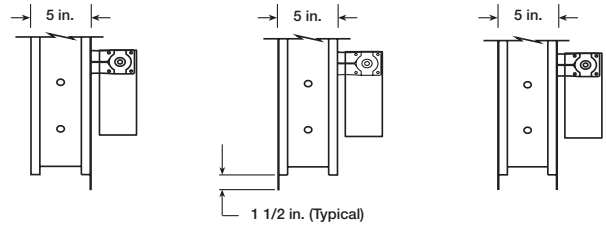

Single Flange

Reversed Flange

Double Flange

* Shown with optional internally mounted actuator.

Document Links

[Installation Instructions](#)



[Product Catalog](#)



[Damper Warranty Statement](#)



AMCA Certified Pressure Drop Data

AMCA 5.2

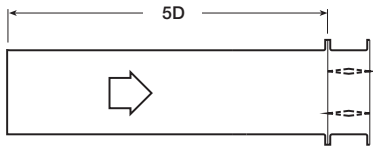

12 in. x 12 in. (305mm x 305mm)

Velocity (fpm)	Pressure Drop (in. wg)
500	0.01
1000	0.03
1500	0.07
2000	0.13
2500	0.19
3000	0.26
3500	0.35
4000	0.45

24 in. x 24 in. (610mm x 610mm)

Velocity (fpm)	Pressure Drop (in. wg)
500	0.01
1000	0.03
1500	0.06
2000	0.10
2500	0.15
3000	0.21
3500	0.28
4000	0.36

36 in. x 36 in. (914mm x 914mm)

Velocity (fpm)	Pressure Drop (in. wg)
500	0.01
1000	0.02
1500	0.04
2000	0.07
2500	0.11
3000	0.15
3500	0.20
4000	0.26

12 in. x 48 in. (305mm x 1219mm)

Velocity (fpm)	Pressure Drop (in. wg)
500	0.01
1000	0.03
1500	0.07
2000	0.11
2500	0.17
3000	0.23
3500	0.31
4000	0.39

48 in. x 12 in. (1219mm x 305mm)

Velocity (fpm)	Pressure Drop (in. wg)
500	0.01
1000	0.02
1500	0.04
2000	0.08
2500	0.12
3000	0.16
3500	0.21
4000	0.27

AMCA 5.3

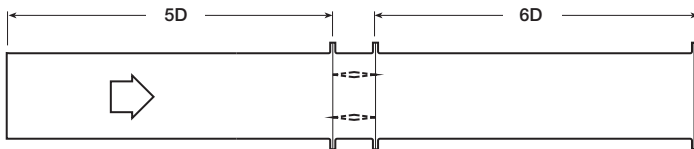

12 in. x 12 in. (305mm x 305mm)

Velocity (fpm)	Pressure Drop (in. wg)
500	0.01
1000	0.02
1500	0.05
2000	0.08
2500	0.12
3000	0.17
3500	0.23
4000	0.30

24 in. x 24 in. (610mm x 610mm)

Velocity (fpm)	Pressure Drop (in. wg)
500	0.01
1000	0.01
1500	0.03
2000	0.05
2500	0.09
3000	0.13
3500	0.17
4000	0.22

36 in. x 36 in. (914mm x 914mm)

Velocity (fpm)	Pressure Drop (in. wg)
500	0.01
1000	0.01
1500	0.02
2000	0.04
2500	0.06
3000	0.08
3500	0.12
4000	0.15

12 in. x 48 in. (305mm x 1219mm)

Velocity (fpm)	Pressure Drop (in. wg)
500	0.01
1000	0.02
1500	0.04
2000	0.08
2500	0.12
3000	0.17
3500	0.22
4000	0.29

48 in. x 12 in. (1219mm x 305mm)

Velocity (fpm)	Pressure Drop (in. wg)
500	0.01
1000	0.02
1500	0.04
2000	0.07
2500	0.11
3000	0.15
3500	0.20
4000	0.25

AMCA 5.5

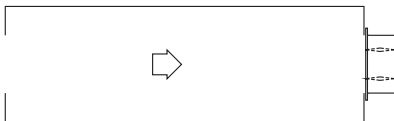

12 in. x 12 in. (305mm x 305mm)

Velocity (fpm)	Pressure Drop (in. wg)
500	0.03
1000	0.12
1500	0.27
2000	0.48
2500	0.74
3000	1.07
3500	1.46
4000	1.91

24 in. x 24 in. (610mm x 610mm)

Velocity (fpm)	Pressure Drop (in. wg)
500	0.03
1000	0.11
1500	0.26
2000	0.45
2500	0.71
3000	1.02
3500	1.40
4000	1.89

36 in. x 36 in. (914mm x 914mm)

Velocity (fpm)	Pressure Drop (in. wg)
500	0.02
1000	0.09
1500	0.21
2000	0.38
2500	0.58
3000	0.85
3500	1.15
4000	1.52

12 in. x 48 in. (305mm x 1219mm)

Velocity (fpm)	Pressure Drop (in. wg)
500	0.03
1000	0.11
1500	0.24
2000	0.43
2500	0.67
3000	0.96
3500	1.31
4000	1.71

48 in. x 12 in. (1219mm x 305mm)

Velocity (fpm)	Pressure Drop (in. wg)
500	0.03
1000	0.11
1500	0.24
2000	0.44
2500	0.68
3000	0.97
3500	1.32
4000	1.73

AMCA Certified Leakage Data

Air leakage is based on operation between 32°F (0°C) and 120°F (49°C).

Tested for leakage in accordance with ANSI/AMCA Standard 500-D, Figure 5.5.

Tested for air performance in accordance with ANSI/AMCA Standard 500-D, Figures 5.2, 5.3 and 5.5.

Torque

Data are based on a torque of 7.0 in.lb./ft² (0.79 N·m) applied to close and seat the damper during the test.

VCD-33	Leakage Class*		
Maximum Damper Width	1 in. wg (0.25 kPa)	4 in. wg (1 kPa)	5 in. wg (1.2 kPa)
60 in. (1524mm)	1A	1	1

*Leakage Class Definitions

The maximum allowable leakage is defined by AMCA as the following:

- Leakage Class 1A - 3 cfm/ft² at 1 in. wg (class 1A is only defined at 1 in. wg).
- Leakage Class 1
 - 4 cfm/ft² at 1 in. wg
 - 8 cfm/ft² at 4 in. wg
 - 11 cfm/ft² at 8 in. wg
 - 12.6 cfm/ft² at 10 in. wg

Velocity Limitations

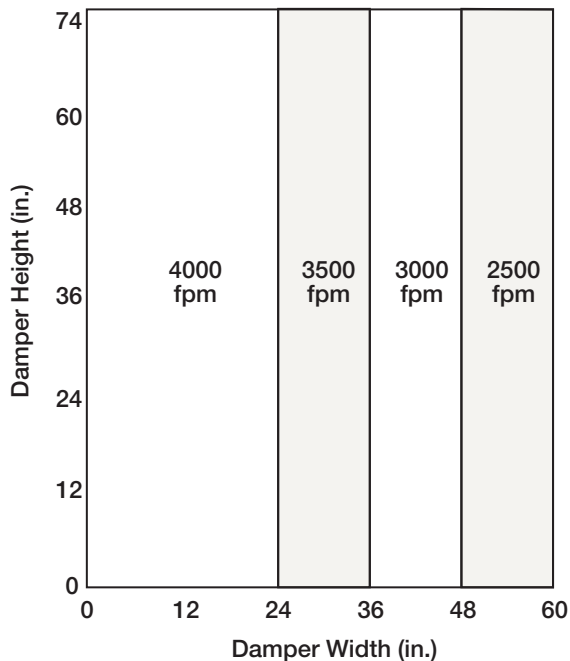

Temperature Limitations

Blade Seal	Temperature Range
TPE	-10°F to 180°F (-23°C to 82°C)
Silicone	-40°F to 250°F (-40°C to 121°C)

Space Envelopes

On dampers less than 18 in. (457mm) high, actuators may also require clearances above and/or below the damper frame. "B" and "T" dimensions are worst case clearance requirements for some dampers less than 18 in. (457mm) high. All damper sizes under 18 in. (457mm) high do not require these worst case clearances. If space availability above or below the damper is limited, each damper size should be individually evaluated.

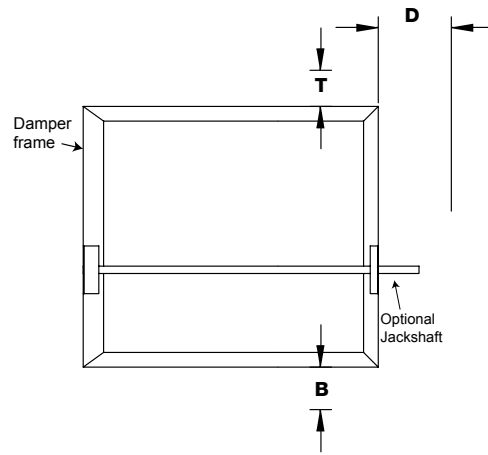

Actuator Type/Model	Height	T	B	D
	Inches			
AFBUP (-S) and FSNF Series, Belimo MSxx20 Series, Honeywell	≥6 to <10	0	12¾	6
	≥10 to <18	0	2	6
	≥18	0	0	10
FSLF, LF and TFB Series, Belimo	≥6 to <10	0	3½	6
	≥10	0	0	6
MSxx04 & MSxx09 Series, Honeywell	≥6 to <9	0	4¾	6
	≥9	0	0	6
MS75xx Series, Honeywell	≥6 to <10	0	12¾	6
	≥10 to <18	0	7	6
	≥18	0	0	6

Mounting

- External - includes extension pin (standoff bracket optional)
- External kit - actuator and all mounting hardware
- Internal - blade lever

Internal mount only Actuator model	A	B	C
All except - EFB & EFCX Series	7 ¾ in (197 mm)	3 ¾ in (95 mm)	5 ⅜ in (136.5 mm)
EFB & EFCX Series	8 ½ in (216 mm)	6 in (152mm)	8 ½ in (216 mm)

This drawing depicts the worse case clearance requirements for an actuator with a jackshaft.

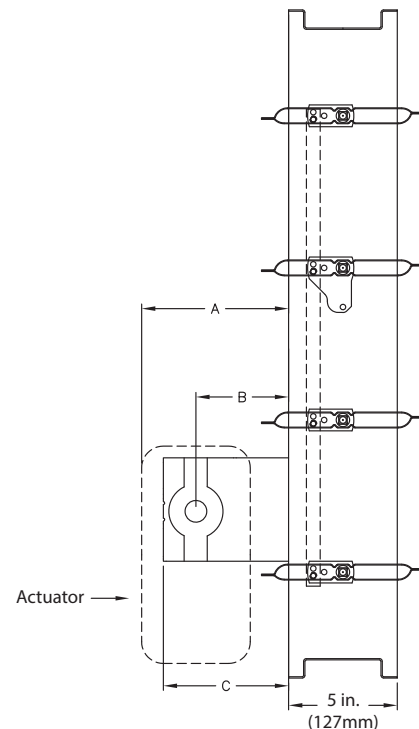

Multi-Section Dampers

Dampers larger than the maximum single section size, will be made up of a multiple of equal size sections. Multiple section dampers can be jackshafted together so that all sections operate together as shown below.

NOTE: Dampers larger than 60 in. x 74 in. (1524mm x 1880mm) are not intended to be structurally self supporting. Additional horizontal bracing is recommended to support the weight of the damper and vertical bracing should be installed as required to hold against system pressure.

Refer to IOM document 483509 for structural support requirements on multi-section assemblies.

