

Application

The VCD-40 is a low leakage control damper with extruded aluminium airfoil blades. Blades are completely contained within the frame allowing the damper to be directly mounted to a louver, filter frame, or similar application with no blade interference.

VCD-40 is IECC (International Energy Conservation Code) compliant with a leakage rating of 3 cfm/ft² at 1 in. wg (55cmh/m² at .25 kPa) or less.

Damper Ratings

Velocity

Up to 6000 fpm (30.5 m/s)

Pressure

Up to 6 in. wg (1.5 kPa) - pressure differential

Leakage

Class 1A at 1 in. wg (0.25 kPa)

Temperature

-40°F to 250°F (-40°C to 121°C). Consult factory for higher temperature

Construction

	Standard	Optional
Frame Material	Aluminum	-
Frame Material Thickness	.125 in. (3.2 mm) minimum wall thickness	-
Frame Type	4 in. x 1 in. (102 mm x 25 mm) hat channel	Single flange, Reversed flange
Blade Material	Extruded Aluminum (6063T5)	-
Blade Type	Airfoil	-
Blade Action	Opposed	Parallel
Blade Seals	TPE	Silicone
Linkage	Plated steel out of airstream, concealed in jamb	316SS
Axle Bearings	Synthetic	316SS
Axle Material	½ in. dia. Plated steel	316SS
Jamb Seal	Stainless Steel	-
Paint Finishes	Mill Finish	Baked Enamel, Hi Pro Polyester, Industrial Epoxy Kynar/Hylar (70% Kynar) Anodize



* W and H dimension furnished approximately ¼ in. (6 mm) undersize. If the height is 6 inches, the damper will be undersized an ⅛ in. (3 mm).

Size Limitations

W x H	Minimum Size	Maximum Size	
		Single Section	Multiple Section
Inches	6 x 6	60 x 74	Unlimited
mm	152 x 152	1524 x 1880	Unlimited

* Note: When damper is more than one section wide, the sections will be 48 in. wide (1219 mm).

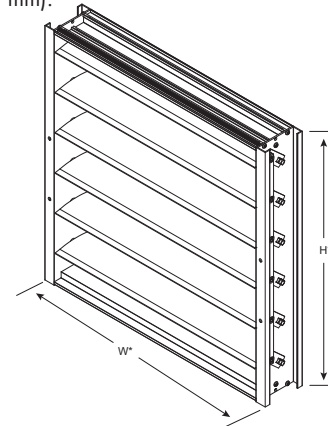

Notes:

- Low profile head and sill are used on sizes less than 17 in. (432mm) high
- Electric actuator and manual quadrant available. Factory supplied actuators are sized for 1500 fpm (7 m/s) and fully closed differential pressure of 2 in. wg (.5 kPa). Contact factory for actuator sizing on applications exceeding those limits.
- In applications where airflow could be uneven, such as a discharge fan, it is imperative to verify that at no point the maximum velocity exceeds the damper's cataloged velocity.
- Blades must be horizontal for either horizontal or vertical mount.

Blade Operation

Parallel blade operation - this configuration requires the damper blades to rotate in the same direction, parallel to one another.

Opposed blade operation - adjacent damper blades rotate opposite one another.

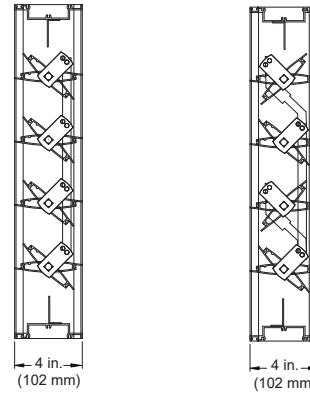

Options

- Actuators (24V, 120V, manual, pull chain)
- Actuator mounting (external, external kit (field assembly), internal)
- Flanges
- NEMA enclosures (3, 4, 4X)
- Retaining angles
- Transformers

Frame Options

Channel Frame

The channel frame option is designed for in-duct or slip-in installation. Dampers with external actuators can be rotated in the field 180 degrees to change from right hand to left hand drive (not recommended on parallel blade dampers).

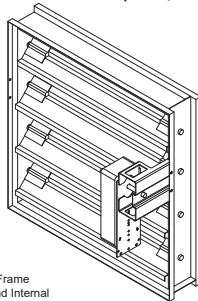

Channel Frame
Right Hand Internal

Reversed Flange

The reversed flange frame option is designed for “flange to wall/ opening” applications. Dampers with external mount actuators must be installed from the interior (cannot be “insert mounted”) to avoid obstructions. Dampers with external actuators can be rotated in the field 180 degrees to change from right hand to left hand drive (not recommended on parallel blade dampers). The flange will be located on the opposite side of the damper frame as the jackshaft/actuator for internal mount actuators.

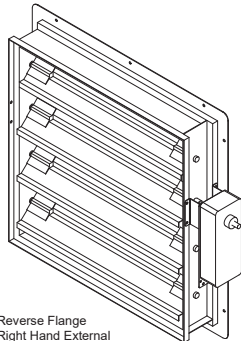

Reverse Flange
Right Hand External

Single Flange

The single flange frame option is designed for “flange to wall/ opening” applications. Dampers with external mount actuators must be installed from the interior (cannot be “insert mounted”) to avoid obstructions. Dampers with external actuators can be rotated in the field 180 degrees to change from right hand to left hand drive (not recommended on parallel blade dampers). The flange will be located on the same side of the damper frame as the jackshaft/actuator for internal mount actuators.

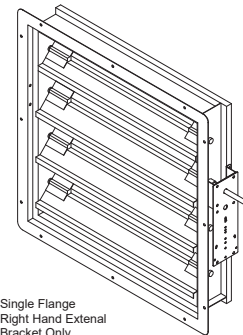

Single Flange
Right Hand External
Bracket Only

Pressure Drop Data

AMCA 5.2

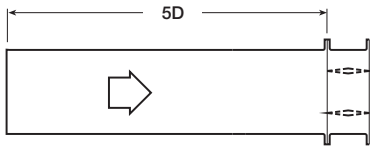

12 in. x 12 in. (305 mm x 305 mm)

Velocity (fpm)	Pressure Drop (in. wg)
500	0.08
1000	0.31
1500	0.69
2000	1.19
2500	1.84
3000	2.67
3500	3.59
4000	4.64

24 in. x 24 in. (610 mm x 610 mm)

Velocity (fpm)	Pressure Drop (in. wg)
500	0.01
1000	0.05
1500	0.11
2000	0.19
2500	0.30
3000	0.43
3500	0.58
4000	0.76

36 in. x 36 in. (914 mm x 914 mm)

Velocity (fpm)	Pressure Drop (in. wg)
500	0.01
1000	0.04
1500	0.09
2000	0.16
2500	0.24
3000	0.35
3500	0.48
4000	0.62

12 in. x 48 in. (305 mm x 1219 mm)

Velocity (fpm)	Pressure Drop (in. wg)
500	0.01
1000	0.05
1500	0.11
2000	0.20
2500	0.30
3000	0.43
3500	0.59
4000	0.77

48 in. x 12 in. (1219 mm x 305 mm)

Velocity (fpm)	Pressure Drop (in. wg)
500	0.06
1000	0.23
1500	0.52
2000	0.91
2500	1.43
3000	2.05
3500	2.82
4000	3.69

AMCA 5.3

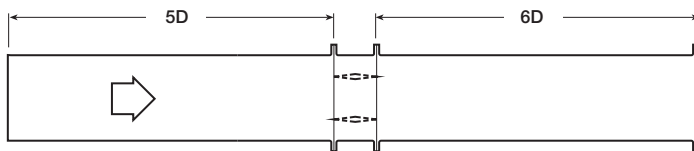

12 in. x 12 in. (305 mm x 305 mm)

Velocity (fpm)	Pressure Drop (in. wg)
500	0.05
1000	0.20
1500	0.45
2000	0.76
2500	1.19
3000	1.70
3500	2.29
4000	2.97

24 in. x 24 in. (610 mm x 610 mm)

Velocity (fpm)	Pressure Drop (in. wg)
500	0.01
1000	0.02
1500	0.05
2000	0.10
2500	0.15
3000	0.22
3500	0.30
4000	0.40

36 in. x 36 in. (914 mm x 914 mm)

Velocity (fpm)	Pressure Drop (in. wg)
500	0.01
1000	0.02
1500	0.04
2000	0.07
2500	0.10
3000	0.15
3500	0.20
4000	0.27

12 in. x 48 in. (305 mm x 1219 mm)

Velocity (fpm)	Pressure Drop (in. wg)
500	0.01
1000	0.03
1500	0.07
2000	0.12
2500	0.19
3000	0.26
3500	0.36
4000	0.46

48 in. x 12 in. (1219 mm x 305 mm)

Velocity (fpm)	Pressure Drop (in. wg)
500	0.03
1000	0.13
1500	0.29
2000	0.51
2500	0.81
3000	1.16
3500	1.59
4000	2.09

AMCA 5.5

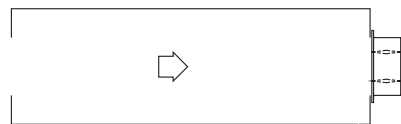

12 in. x 12 in. (305 mm x 305 mm)

Velocity (fpm)	Pressure Drop (in. wg)
500	0.1
1000	0.40
1500	0.88
2000	1.54
2500	2.41
3000	3.45
3500	4.75
4000	6.09

24 in. x 24 in. (610 mm x 610 mm)

Velocity (fpm)	Pressure Drop (in. wg)
500	0.03
1000	0.12
1500	0.29
2000	0.52
2500	0.80
3000	1.14
3500	1.60
4000	2.14

36 in. x 36 in. (914 mm x 914 mm)

Velocity (fpm)	Pressure Drop (in. wg)
500	0.03
1000	0.11
1500	0.26
2000	0.46
2500	0.72
3000	1.04
3500	1.43
4000	1.87

12 in. x 48 in. (305 mm x 1219 mm)

Velocity (fpm)	Pressure Drop (in. wg)
500	0.03
1000	0.12
1500	0.27
2000	0.49
2500	0.76
3000	1.11
3500	1.53
4000	2.00

48 in. x 12 in. (1219 mm x 305 mm)

Velocity (fpm)	Pressure Drop (in. wg)
500	0.08
1000	0.29
1500	0.63
2000	1.12
2500	1.76
3000	2.52
3500	3.40
4000	4.52

Leakage

Air leakage is based on operation between 32°F (0°C) and 120°F (49°C).

Tested for leakage in accordance with ANSI/AMCA Standard 500-D, Figure 5.5.

Tested for air performance in accordance with ANSI/AMCA Standard 500-D, Figures 5.2, 5.3, and 5.5.

Torque

Data are based on torque of 5.0 in. lb./ft² (0.56 N·m) applied to close and seat the damper during the test.

VCD-40 Maximum Damper Width	Leakage Class*					
	1 in. wg (0.25 kPa)	2 in. wg (0.5 kPa)	3 in. wg (0.75 in. wg)	4 in. wg (1 kPa)	5 in. wg (1.25 kPa)	6 in. wg (1.5 kPa)
36 in. (914mm)	1A	1	1	1	1	1
48 in. (1219mm)	1A	1	1	1	2	N/A
60 in. (1524mm)	1A	2	2	N/A	N/A	N/A

*Leakage Class Definitions

The maximum allowable leakage is defined as the following:

- Leakage Class 1A - 3 cfm/ft² at 1 in. wg (class 1A is only defined at 1 in. wg).
- Leakage Class 1
 - 4 cfm/ft² at 1 in. wg
 - 8 cfm/ft² at 4 in. wg
 - 11 cfm/ft² at 8 in. wg
 - 12.6 cfm/ft² at 10 in. wg

Temperature Limitations

Blade Seal	Temperature Range
TPE	-10°F to 200°F (-23°C to 93°C)
Silicone	-40°F to 250°F (-40°C to 121°C)

Space Envelopes

On dampers less than 18 in. (457mm) high, actuators may also require clearances above and/or below the damper frame. "B" and "T" dimensions are worst case clearance requirements for some dampers less than 18 in. (457mm) high. All damper sizes under 18 in. (457mm) high do not require these worst case clearances. If space availability above or below the damper is limited, each damper size should be individually evaluated.

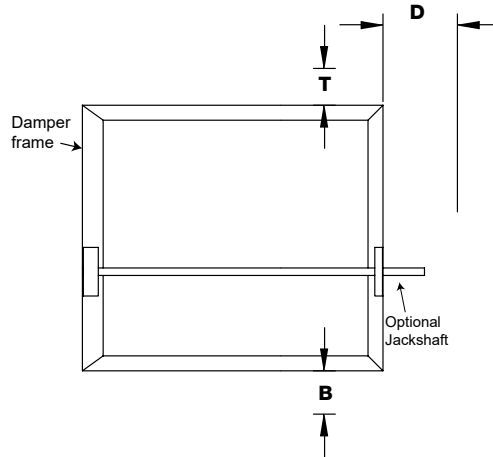

Actuator Type/Model	Height	T	B	D
	Inches	Inches		
AFBUP (-S) and FSNF Series, Belimo MSxx20 Series, Honeywell	≥6 to <10	0	12¾	6¼
	≥10 to <18	0	2	6¼
	≥18	0	0	6¼
FSLF, LF and TFB Series, Belimo	≥6 to <10	0	3½	6¼
	≥10	0	0	6¼
MSxx04 & MSxx09 Series, Honeywell	≥6 to <9	0	4¾	6¼
	≥9	0	0	6¼
MS75xx Series, Honeywell	≥6 to <10	0	12¾	6¼
	≥10 to <18	0	7	6¼
	≥18	0	0	6¼
GRD and GVD Series, Siemens	≥6 to <10	0	12¾	6¼
	≥10 to <18	0	2	6¼
	≥18	0	0	6¼
GJD Series, Siemens	≥6 to <10	0	3½	6¼
	≥10 to <18	0	0	6¼
	≥18	0	0	6¼

Actuator Mounting

Actuators may be installed at the factory or shipped loose with the necessary linkage and brackets required for mounting. For more detail information on actuator mounting, click on link below or scan QR code.



[ACTUATOR MOUNTING](#)

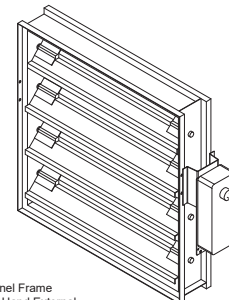

Channel Frame
Right Hand External

Clearance Requirements

This drawing depicts the worst case clearance requirements for an actuator with a jackshaft.

Internal mount only Actuator model	A	B	C
All except - EFB & EFCX Series	7 ¾ in (197 mm)	3 ¾ in (95 mm)	5 ⅜ in (137 mm)
EFB & EFCX Series	8 ½ in (216 mm)	6 in (152mm)	8 ½ in (216 mm)

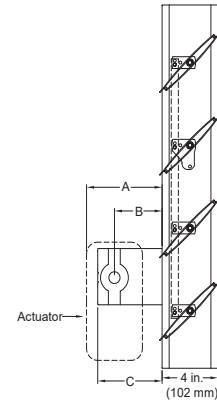

Multi-Section Dampers

Dampers larger than the maximum single section size, will be made up of a multiple of equal size sections. Multiple section dampers can be jackshafted together so that all sections operate together as shown below.

Note: Dampers larger than 60 in. x 74 in. (1524mm x 1880mm) are not intended to be structurally self supporting. Refer to IOM document 483509 for structural support requirements on multi-section assemblies.

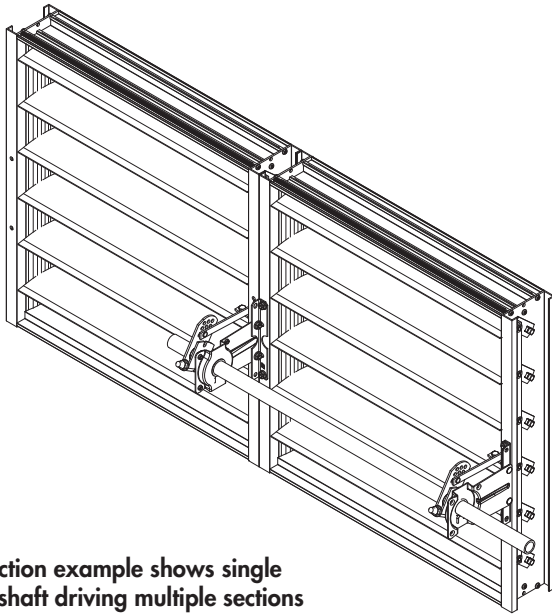

2 section example shows single jackshaft driving multiple sections

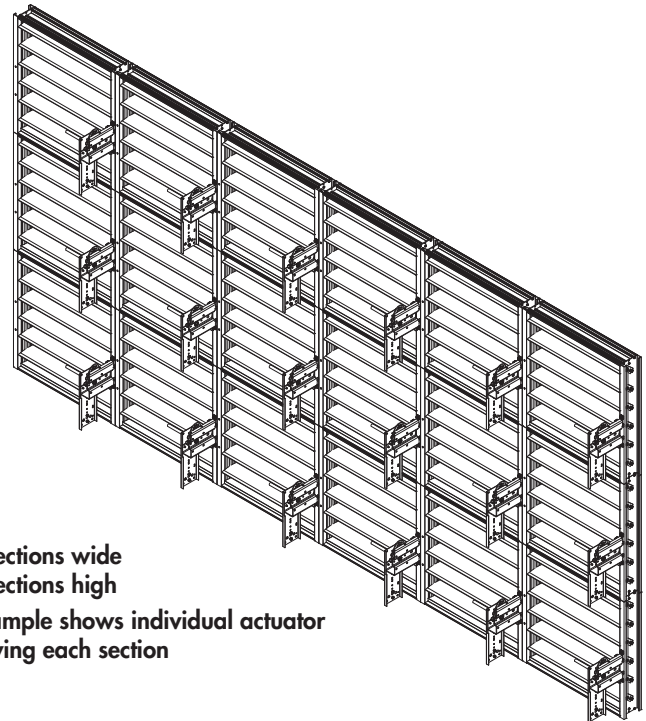

6 sections wide
3 sections high
example shows individual actuator driving each section

Document Links



[INSTALLATION](#)



[CATALOG](#)



[SELECTION GUIDE](#)



[WARRANTY](#)