

Application

The VCD-42 is a low leakage damper with extruded aluminum airfoil blades and galvanized steel frame. Smooth profile extruded aluminum airfoil blades insure the lowest resistance to airflow in HVAC systems. The VCD-42 is intended for application in medium to high pressure and velocity systems.

VCD-42 is IECC (International Energy Conservation Code) compliant with a leakage rating of 3 cfm/ft² at 1 in. wg (55 cmh/m² at .25 kPa) or less.

Damper Ratings

Velocity

Up to 6000 fpm (30.5 m/s)

Leakage

6 cfm/ft² at 4 in. wg (110 cmh/m² at 1 kPa)
3 cfm/ft² at 1 in. wg (55 cmh/m² at .25 kPa)

Pressure

Up to 6 in. wg (1.5 kPa) pressure differential

Temperature

-40°F to 250°F (-40°C to 121°C).

Construction

	Standard	Optional
Frame Material	Galvanized Steel	-
Frame Thickness	16 ga. (1.5 mm)	12 ga. (2.7 mm)*
Frame Type	5 in. x 1 in. (127mm x 25mm) hat channel	Single flange, Reversed flange, Double flange
Blade Material	Extruded Aluminum (6063T5)	-
Blade Type	Airfoil	-
Blade Action	Opposed	Parallel
Linkage	Plated steel out of airstream, concealed in jamb	316SS
Axle Bearings	Synthetic (acetal) sleeve	316SS
Axle Material	Plated steel	316SS
Blade Seals	TPE	Silicone
Jamb Seals	Stainless Steel	-
Finish	Mill finish	Baked Enamel, Hi Pro Polyester, Industrial Epoxy

*When 12 ga. frame is selected and the damper height is less than 17 inches, low profile top and bottom frame members are utilized. These low profile frame members will be made from 16 ga. material.



*W&H dimension furnished approximately 1/4 in. (6mm) undersize.

Size Limitations

W x H	Minimum Size	Maximum Size	
		Single Section	Multiple Section
Inches	6 x 6	60 x 74	Unlimited
mm	152 x 152	1524 x 1880	Unlimited

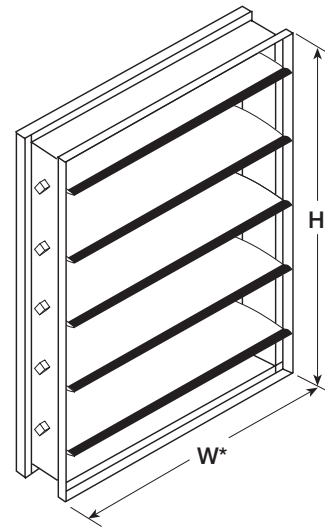

Notes:

- Low profile head and sill are used on sizes less than 17 in. (432mm) high
- Electric actuator and manual quadrant available. Factory supplied actuators are sized for 1500 fpm (7m/s) and fully closed differential pressure of 2 in. wg (.5 kPa). Contact factory for actuator sizing on applications exceeding those limits.
- In applications where airflow could be uneven, such as a discharge fan, it is imperative to verify that at no point the maximum velocity exceeds the damper's cataloged velocity.
- Blades must be horizontal for either horizontal or vertical mount.

Blade Operation

Parallel blade operation - this configuration requires the damper blades to rotate in the same direction, parallel to one another.

Opposed blade operation - adjacent damper blades rotate opposite one another.

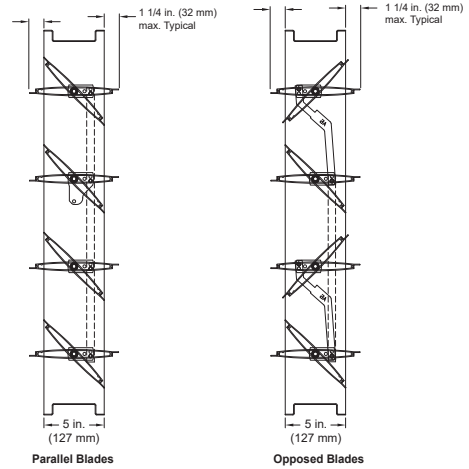

Options

- Actuators (24V, 120V, manual, pull chain)
- Actuator mounting (external, external kit (field assembly), internal)
- Flanges
- NEMA enclosures (3, 4, 4X, 7)
- Retaining angles
- Transformers

Flange options

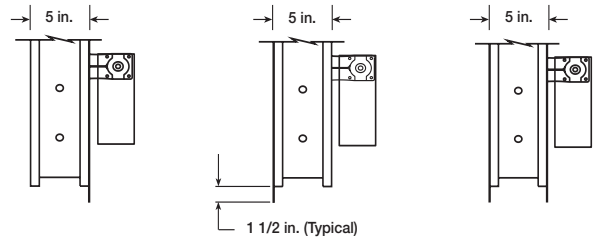

Single Flange

Reversed Flange

Double Flange

Shown with optional internally mounted actuator.

Pressure Drop Data

This pressure drop testing was conducted in accordance with AMCA Standard 500-D using the three configurations shown. All data has been corrected to represent standard air at a density of 0.075 lb/ft³ (1.201 kg/m³).

Actual pressure drop found in any HVAC system is a combination of many factors. This pressure drop information along with an analysis of other system influences should be used to estimate actual pressure losses for a damper installed in a given HVAC system.

AMCA Test Figures

Figure 5.3 Illustrates a fully ducted damper. This configuration has the lowest pressure drop of the three test configurations because entrance and exit losses are minimized by straight duct runs upstream and downstream of the damper.

Figure 5.2 Illustrates a ducted damper exhausting air into an open area. This configuration has a lower pressure drop than Figure 5.5 because entrance losses are minimized by a straight duct run upstream of the damper.

Figure 5.5 Illustrates a plenum mounted damper. This configuration has the highest pressure drop because of extremely high entrance and exit losses due to the sudden changes of area in the system.

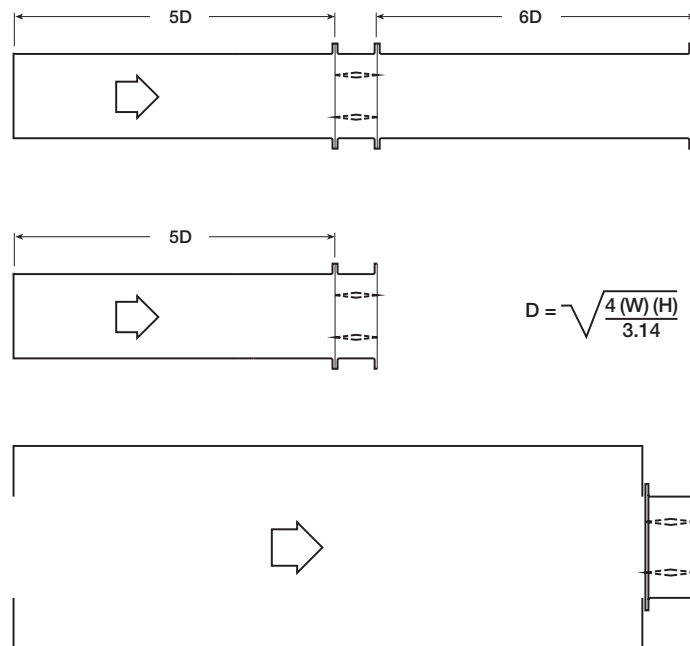

Dimension inches	12x12			24x24			36x36			12x48			48x12		
	5.2	5.3	5.5	5.2	5.3	5.5	5.2	5.3	5.5	5.2	5.3	5.5	5.2	5.3	5.5
AMCA figure	5.2	5.3	5.5	5.2	5.3	5.5	5.2	5.3	5.5	5.2	5.3	5.5	5.2	5.3	5.5
Velocity (ft/min)	Pressure Drop in. wg														
500	.05	.03	.07	.01	.01	.04	.01	.01	.02	.01	.01	.03	.03	.02	.05
1000	.18	.12	.28	.05	.03	.17	.04	.02	.12	.01	.04	.18	.11	.06	.19
1500	.43	.28	.62	.12	.06	.37	.09	.05	.28	.14	.09	.40	.25	.14	.44
2000	.76	.49	1.11	.22	.11	.66	.17	.08	.50	.25	.16	.72	.44	.25	.78
2500	1.19	.77	1.73	.34	.17	1.04	.26	.13	.78	.39	.25	1.12	.69	.39	1.21
3000	1.71	1.11	2.50	.49	.24	1.50	.38	.19	1.13	.57	.36	1.62	1.0	.57	1.75
3500	2.33	1.51	3.41	.66	.33	2.04	.51	.26	1.53	.77	.49	2.21	1.36	.77	2.38
4000	3.04	1.98	4.45	.87	.43	2.66	.67	.34	2.01	1.01	.64	2.88	1.78	1.01	3.11

Leakage

Damper leakage (with blades fully closed) varies based on the type of low leakage seals applied. Model VCD-42 is available with silicone blade seals and stainless steel jamb seals. Leakage testing was conducted in accordance with AMCA Standard 500-D and is expressed as cfm/ft² of damper face area. All data has been corrected to represent standard air at a density of 0.075 lb/ft³ (1.201 kg/m³).

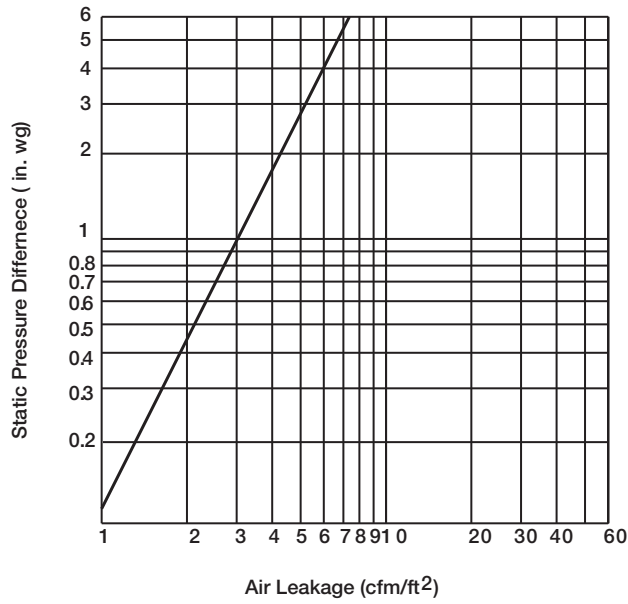

Pressure Limitations

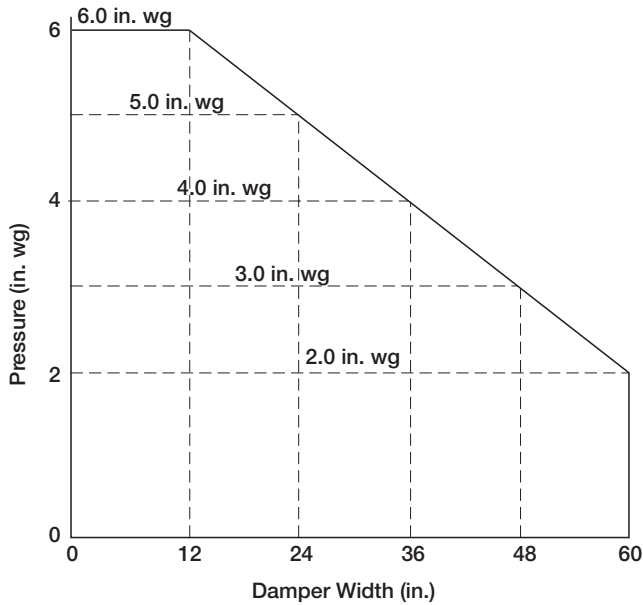

Velocity Limitations

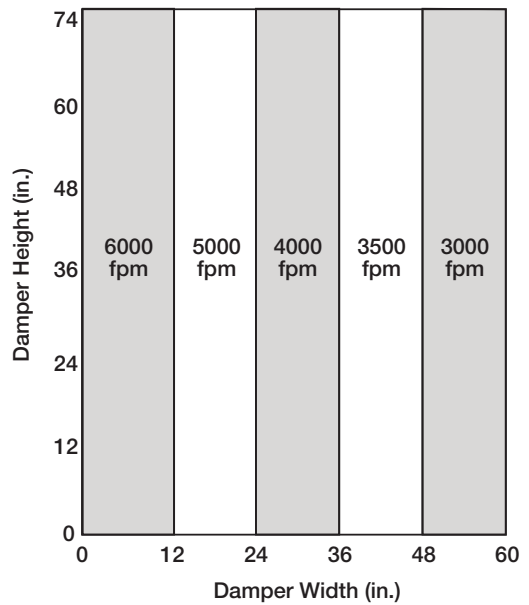

Temperature Limitations

Blade Seal	Temperature Range
TPE	-10°F to 180°F (-23°C to 82°C)
Silicone	-40°F to 250°F (-40°C to 121°C)

NOTE: VCD-42 will withstand higher pressures and velocities. Displayed ratings are conservative to prevent misapplication. Consult factory if you have an application outside these limitations.

Space Envelopes

On dampers less than 18 in. (457mm) high, actuators may also require clearances above and/or below the damper frame. "B" and "T" dimensions are worst case clearance requirements for some dampers less than 18 in. (457mm) high. All damper sizes under 18 in. (457mm) high do not require these worst case clearances. If space availability above or below the damper is limited, each damper size should be individually evaluated.

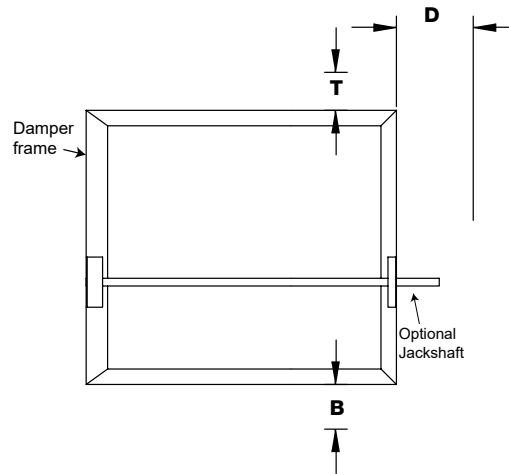

Actuator Type/Model	Height	T	B	D
	Inches	Inches		
AFBUP (-S) and FSNF Series, Belimo MSxx20 Series, Honeywell	≥6 to <10	0	12 ³ / ₄	6 ¹ / ₄
	≥10 to <18	0	2	6 ¹ / ₄
	≥18	0	0	6 ¹ / ₄
FSLF, LF and TFB Series, Belimo	≥6 to <10	0	3 ¹ / ₂	6 ¹ / ₄
	≥10	0	0	6 ¹ / ₄
MSxx04 & MSxx09 Series, Honeywell	≥6 to <9	0	4 ³ / ₄	6 ¹ / ₄
	≥9	0	0	6 ¹ / ₄
MS75xx Series, Honeywell	≥6 to <10	0	12 ³ / ₄	6 ¹ / ₄
	≥10 to <18	0	7	6 ¹ / ₄
	≥18	0	0	6 ¹ / ₄
GRD and GVD Series, Siemens	≥6 to <10	0	12 ³ / ₄	6 ¹ / ₄
	≥10 to <18	0	2	6 ¹ / ₄
	≥18	0	0	6 ¹ / ₄
GJD Series, Siemens	≥6 to <10	0	3 ¹ / ₂	6 ¹ / ₄
	≥10 to <18	0	0	6 ¹ / ₄
	≥18	0	0	6 ¹ / ₄

Actuator Mounting

Actuators may be installed at the factory or shipped loose with the necessary linkage and brackets required for mounting. For more detail information on actuator mounting, click on link below or scan QR code.



[ACTUATOR MOUNTING](#)

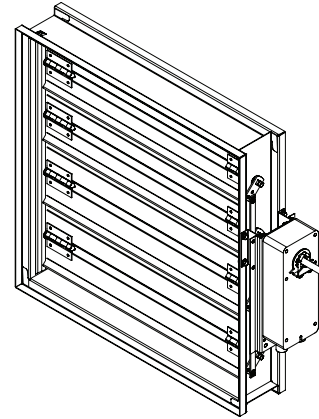

Non-jackshaft external right

Clearance Requirements

This drawing depicts the worst case clearance requirements for an actuator with a jackshaft.

Internal mount only Actuator model	A	B	C
All except - EFB & EFCX Series	7 3/4 in (197 mm)	3 3/4 in (95 mm)	5 3/8 in (136.5 mm)
EFB & EFCX Series	8 1/2 in (216 mm)	6 in (152mm)	8 1/2 in (216 mm)

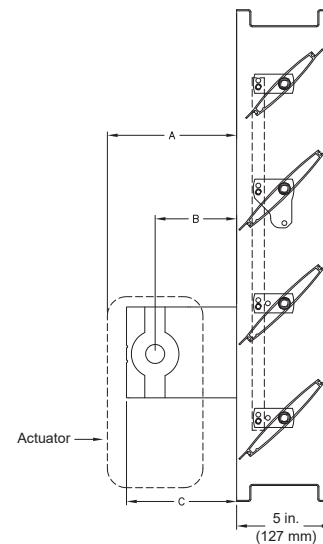

Multi-Section Dampers

Dampers larger than the maximum single section size, will be made up of a multiple of equal size sections. Multiple section dampers can be jackshafted together so that all sections operate together as shown below.

Note: Dampers larger than 60 in. x 74 in. (1524mm x 1880mm) are not intended to be structurally self supporting. Refer to IOM document 483509 for structural support requirements on multi-section assemblies.

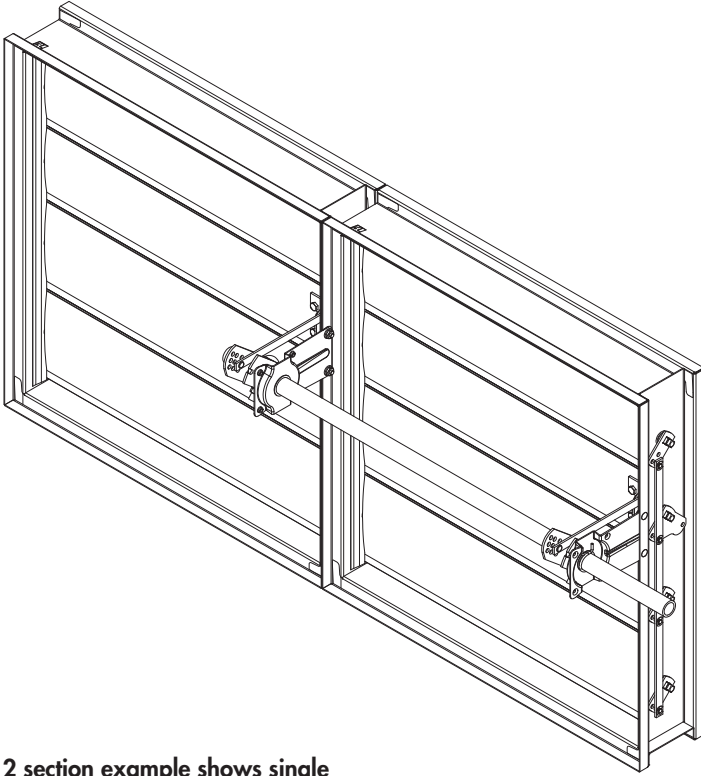

2 section example shows single jackshaft driving multiple sections

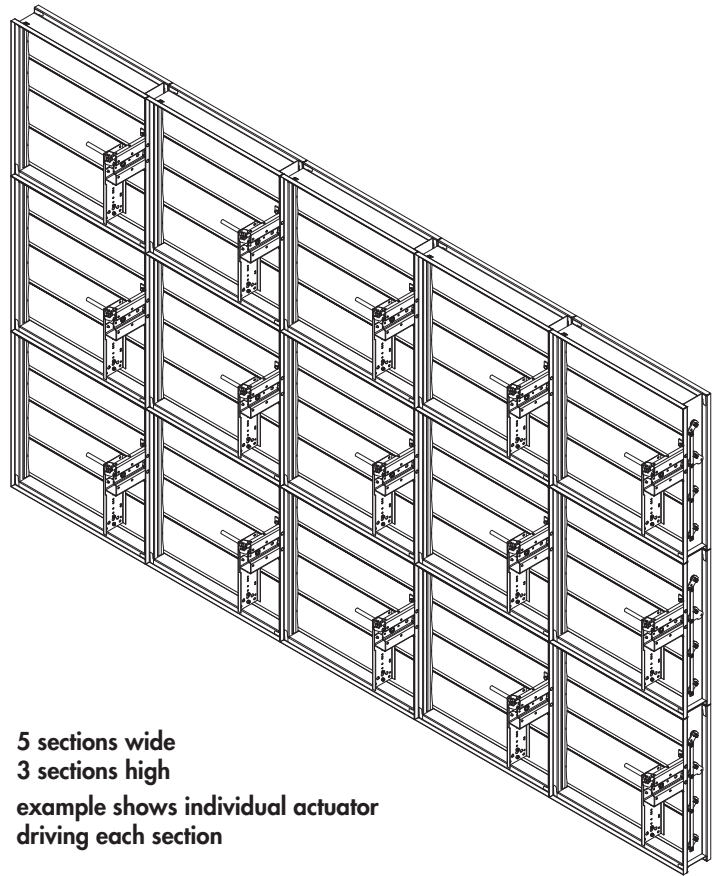

5 sections wide
3 sections high
example shows individual actuator driving each section

Document Links



[INSTALLATION](#)



[CATALOG](#)



[SELECTION GUIDE](#)



[WARRANTY](#)



Copyright © 2025 Venco Products

VCD-42, R9, January 2025

Venco Products reserves the right to make product changes without notice.