

Application

The VCD-43 is a low leakage damper with extruded aluminum airfoil blades and frame. Smooth profile extruded aluminum airfoil blades insure the lowest resistance to airflow in HVAC systems. This model is intended for application in medium to high pressure and velocity systems.

VCD-43 is IECC (International Energy Conservation Code) compliant with a leakage rating of 3 cfm/ft² at 1 in. wg (55 cmh/m² at .25 kPa) or less.

Damper Ratings

Velocity

Up to 6000 fpm (30.5 m/s)

Pressure

Up to 8 in. wg (2 kPa) - pressure differential
For pressures greater than 8 in. wg, consult factory

Leakage

Class 1A at 1 in. wg (0.25 kPa)
Class 1 up to 4-8 in. wg (1-2 kPa)

Temperature

-40°F to 250°F (-40°C to 121°C)

Construction

	Standard	Optional
Frame Material	Aluminum (6063T5)	-
Frame Material Thickness	.125 in. (3.2 mm)	-
Frame Type	5 in. x 1 in. hat channel (127 mm x 25 mm)	Single flange, Reversed flange, Quick connect
Blade Material	Extruded Aluminum (6063T5)	-
Blade Type	Airfoil	-
Blade Action	Opposed	Parallel
Blade Seals	TPE	Silicone
Linkage	Plated steel out of airstream, concealed in jamb	316SS
Axle Bearings	Synthetic (acetal) sleeve	316SS
Axle Material	Plated steel	316SS
Jamb Seal	Stainless Steel	-
Paint Finishes	Mill Finish	Baked Enamel, Hi Pro Polyester, Industrial Epoxy, Kynar/Hylar (70%), Anodize



*W&H dimension furnished approximately 1/4 in. (6mm) undersize.

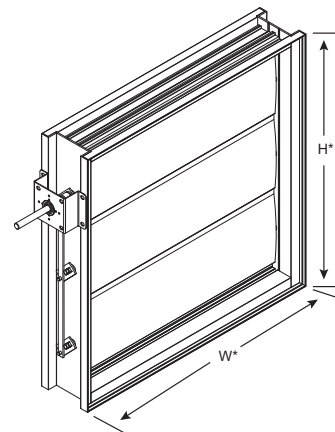

Standard frame shown. See page 3 for more frame options.

Size Limitations

W x H in. (mm)	Frame Type	
	Channel, Single, or Reverse Flange	Quick Connect
Minimum Sizes*	8 x 6 (203 x 178)	8 x 5 (203 x 127)
Maximum Sizes	Single Section	60 x 78 (1524 x 1981)
	Multiple Section	288 x 234 (7315 x 5944)
		60 x 76 (1524 x 1930)
		144 x 152 (3658 x 3861)

* varies by actuator

Note

- Low profile head and sill are used on sizes less than 17 in. high (432mm), excluding quick connect frame.
- Electric actuators and manual operators available. Factory supplied actuators are sized for 1500 fpm (7 m/s) and fully-closed differential pressure of 2 in. wg (.5 kPa). Contact factory for actuator sizing on applications exceeding those limits.
- In applications where airflow could be uneven, such as a discharge fan, it is imperative to verify that at no point the maximum velocity exceeds the damper's cataloged velocity.
- Blades must be horizontal for either horizontal or vertical mount. See VCD-43V model for vertical blade applications.

Blade Operation

Parallel blade operation - this configuration requires the damper blades to rotate in the same direction, parallel to one another.

Opposed blade operation - adjacent damper blades rotate opposite one another.

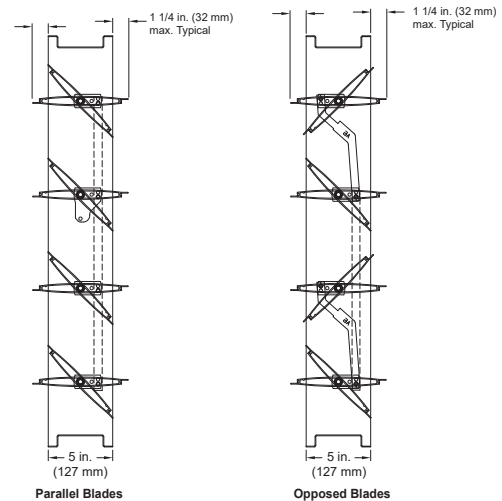

Options

- Actuators (24V, 120V, manual, pull chain, bracket only)
- Actuator mounting (external, external kit (field assembly), internal)
- NEMA enclosures (3, 4, 4X, 7)
- OCI (open or closed indicator)
- Transformers

Frame/Flange Options

Single Flange

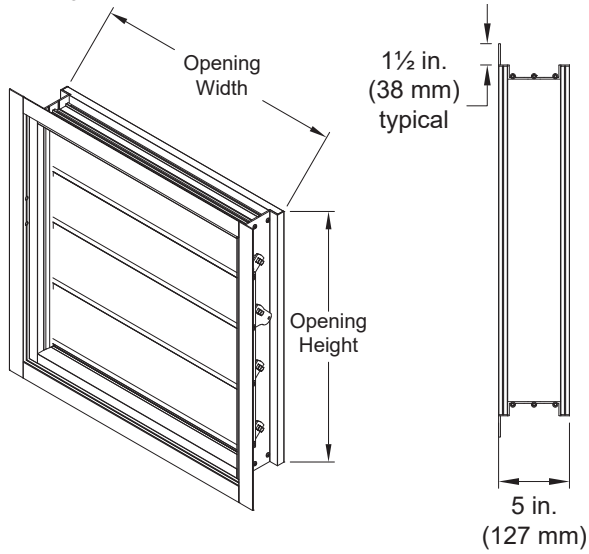

Reverse Flange

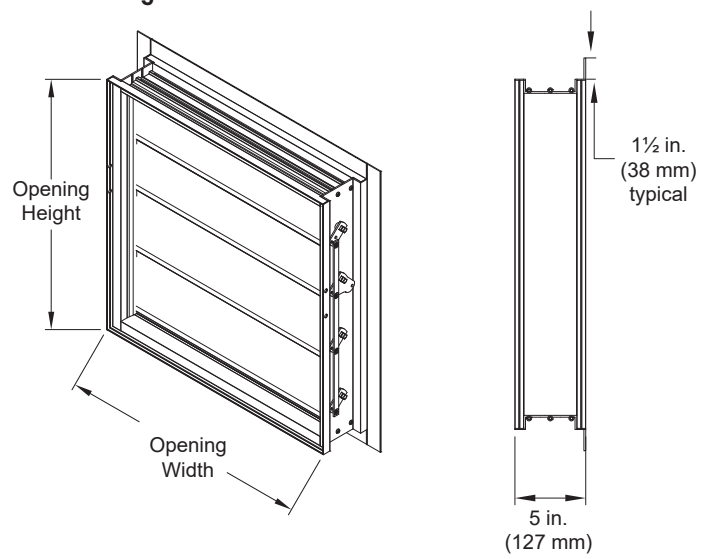

* Width and height is based on outside dimension. W & H dimensions furnished approximately ¼ in. (6mm) undersize.

Quick Connect

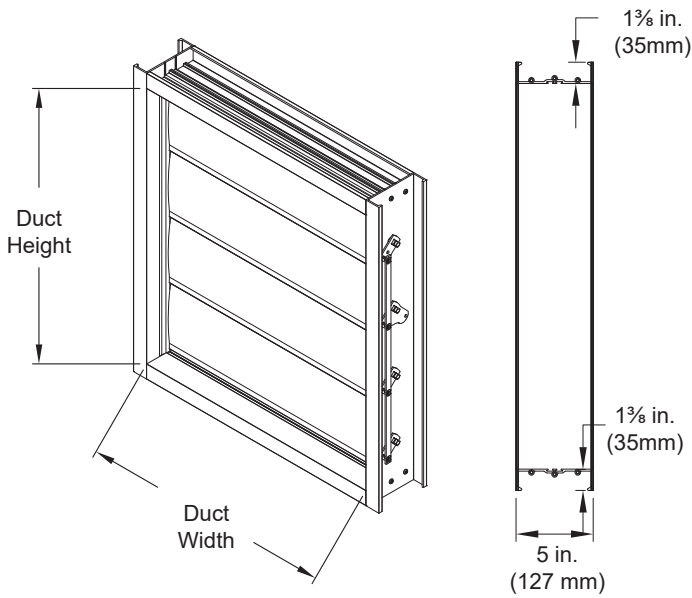

Note: When ordering the Quick Connect Frame, size is based on duct size (or inside dimension of the damper frame). Quick connect frame is actual size.

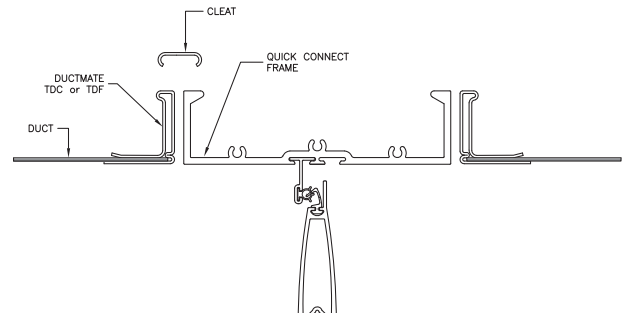

AMCA Certified Pressure Drop Data

AMCA 5.2

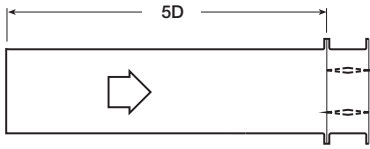

12 in. x 12 in. (305mm x 305mm)

Velocity (fpm)	Pressure Drop (in. wg)
500	0.01
1000	0.06
1500	0.13
2000	0.23
2500	0.35
3000	0.50
3500	0.68
4000	0.88

24 in. x 24 in. (610mm x 610mm)

Velocity (fpm)	Pressure Drop (in. wg)
500	0.01
1000	0.04
1500	0.10
2000	0.18
2500	0.28
3000	0.40
3500	0.54
4000	0.70

36 in. x 36 in. (914mm x 914mm)

Velocity (fpm)	Pressure Drop (in. wg)
500	0.01
1000	0.03
1500	0.06
2000	0.12
2500	0.18
3000	0.26
3500	0.35
4000	0.46

12 in. x 48 in. (305mm x 1219mm)

Velocity (fpm)	Pressure Drop (in. wg)
500	0.01
1000	0.06
1500	0.13
2000	0.23
2500	0.36
3000	0.51
3500	0.71
4000	0.93

48 in. x 12 in. (1219mm x 305mm)

Velocity (fpm)	Pressure Drop (in. wg)
500	0.01
1000	0.03
1500	0.06
2000	0.10
2500	0.16
3000	0.23
3500	0.30
4000	0.39

AMCA 5.3

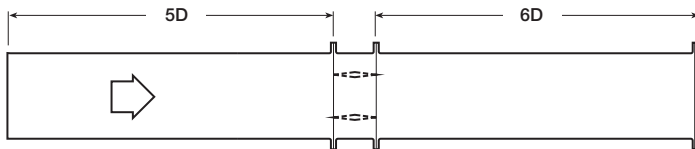

12 in. x 12 in. (305mm x 305mm)

Velocity (fpm)	Pressure Drop (in. wg)
500	0.01
1000	0.03
1500	0.07
2000	0.14
2500	0.21
3000	0.29
3500	0.39
4000	0.51

24 in. x 24 in. (610mm x 610mm)

Velocity (fpm)	Pressure Drop (in. wg)
500	0.01
1000	0.02
1500	0.04
2000	0.08
2500	0.13
3000	0.19
3500	0.26
4000	0.34

36 in. x 36 in. (914mm x 914mm)

Velocity (fpm)	Pressure Drop (in. wg)
500	0.01
1000	0.01
1500	0.02
2000	0.04
2500	0.06
3000	0.09
3500	0.13
4000	0.17

12 in. x 48 in. (305mm x 1219mm)

Velocity (fpm)	Pressure Drop (in. wg)
500	0.01
1000	0.03
1500	0.06
2000	0.11
2500	0.17
3000	0.25
3500	0.34
4000	0.45

48 in. x 12 in. (1219mm x 305mm)

Velocity (fpm)	Pressure Drop (in. wg)
500	0.01
1000	0.02
1500	0.04
2000	0.08
2500	0.12
3000	0.18
3500	0.24
4000	0.31

AMCA 5.5

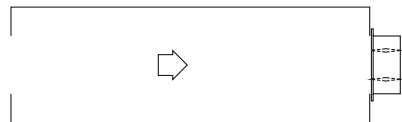

12 in. x 12 in. (305mm x 305mm)

Velocity (fpm)	Pressure Drop (in. wg)
500	0.04
1000	0.14
1500	0.31
2000	0.55
2500	0.86
3000	1.23
3500	1.67
4000	2.19

24 in. x 24 in. (610mm x 610mm)

Velocity (fpm)	Pressure Drop (in. wg)
500	0.03
1000	0.12
1500	0.27
2000	0.48
2500	0.75
3000	1.07
3500	1.47
4000	1.91

36 in. x 36 in. (914mm x 914mm)

Velocity (fpm)	Pressure Drop (in. wg)
500	0.03
1000	0.10
1500	0.22
2000	0.39
2500	0.61
3000	0.87
3500	1.19
4000	1.56

12 in. x 48 in. (305mm x 1219mm)

Velocity (fpm)	Pressure Drop (in. wg)
500	0.03
1000	0.11
1500	0.25
2000	0.46
2500	0.72
3000	1.05
3500	1.43
4000	1.87

48 in. x 12 in. (1219mm x 305mm)

Velocity (fpm)	Pressure Drop (in. wg)
500	0.03
1000	0.11
1500	0.26
2000	0.46
2500	0.72
3000	1.02
3500	1.40
4000	1.83

AMCA Certified Leakage

Air leakage is based on operation between 32°F (0°C) and 120°F (49°C).

Tested for leakage in accordance with ANSI/AMCA Standard 500-D, Figure 5.5.

Tested for air performance in accordance with ANSI/AMCA Standard 500-D, Figures 5.2, 5.3 and 5.5.

Torque

Data are based on a torque of 5.0 in.lb./ft² (0.56 N·m) applied to close and seat the damper during the test.

VCD-43	Leakage Class*		
Maximum Damper Width	1 in. wg (0.25 kPa)	4 in. wg (1 kPa)	8 in. wg (2 kPa)
60 in. (1524mm)	1A	1	1

* applies to opposed blades only

*Leakage Class Definitions

The maximum allowable leakage is defined as the following:

- Leakage Class 1A - 3 cfm/ft² at 1 in. wg (class 1A is only defined at 1 in. wg).
- Leakage Class 1
 - 4 cfm/ft² at 1 in. wg
 - 8 cfm/ft² at 4 in. wg
 - 11 cfm/ft² at 8 in. wg
 - 12.6 cfm/ft² at 10 in. wg

Velocity and Temperature Limitations

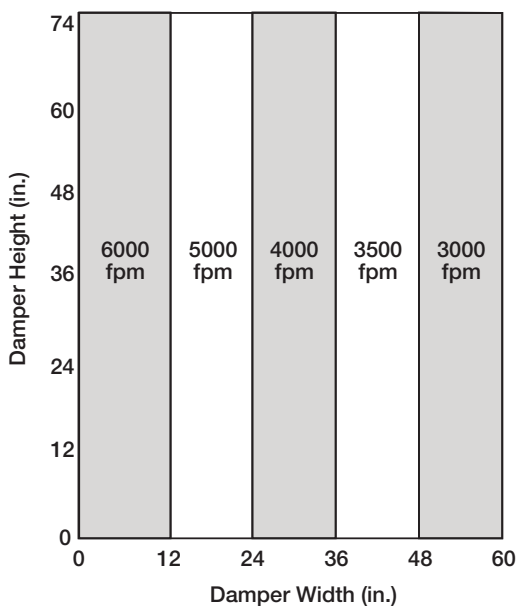

Temperature Limitations

Blade Seal	Temperature Range
TPE	-10°F to 180°F (-23°C to 82°C)
Silicone	-40°F to 250°F (-40°C to 121°C)

Space Envelopes

Externally mounted actuators always require space outside the damper. The "D" dimension illustrates the clearance required for various available actuators. Dampers less than 18 in. (457mm) high may require actuator clearances above and/or below the damper frame. "B" and "T" dimensions are worst case clearance requirements for some dampers less than 18 in. (457mm) high. All damper sizes under 18 in. (457mm) high do not require these worst case clearances. If space availability above or below the damper is limited, each damper size should be individually evaluated.

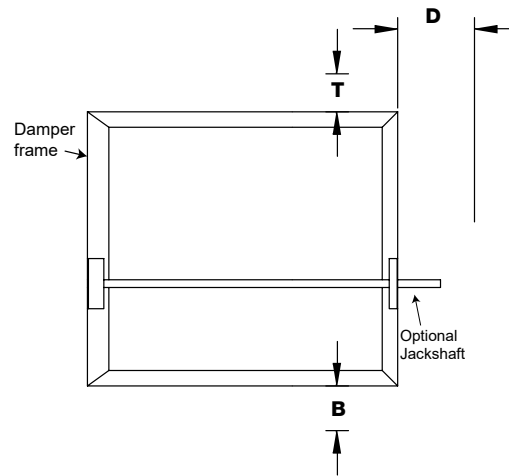

Actuator Type/Model	Height	T	B	D
	Inches	Inches		
AFBUP (-S) and FSNF Series, Belimo MSxx20 Series, Honeywell	≥6 to <10	0	12¾	6¼
	≥10 to <18	0	2	6¼
	≥18	0	0	6¼
FSLF, LF and TFB Series, Belimo	≥6 to <10	0	3½	6¼
	≥10	0	0	6¼
MSxx04 & MSxx09 Series, Honeywell	≥6 to <9	0	4¾	6¼
	≥9	0	0	6¼
MS75xx Series, Honeywell	≥6 to <10	0	12¾	6¼
	≥10 to <18	0	7	6¼
	≥18	0	0	6¼
GRD and GVD Series, Siemens	≥6 to <10	0	12¾	6¼
	≥10 to <18	0	2	6¼
	≥18	0	0	6¼
GJD Series, Siemens	≥6 to <10	0	3½	6¼
	≥10 to <18	0	0	6¼
	≥18	0	0	6¼

Actuator Mounting

Actuators may be installed at the factory, shipped loose with the necessary linkage and brackets for mounting, or field supplied. For more detail information on actuator mounting, click on link below or scan QR code.



[ACTUATOR MOUNTING](#)

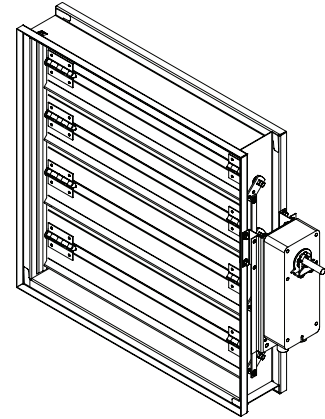

Non-jackshaft external right

Clearance Requirements

This drawing depicts the worst case clearance requirements for an actuator with a jackshaft.

Internal mount only Actuator model	A	B	C
All except - EFB & EFCX Series	7¼ in. (197 mm)	3¾ in. (95 mm)	5⅜ in. (136.5 mm)
EFB & EFCX Series	8½ in. (216 mm)	6 in. (152mm)	8½ in. (216 mm)

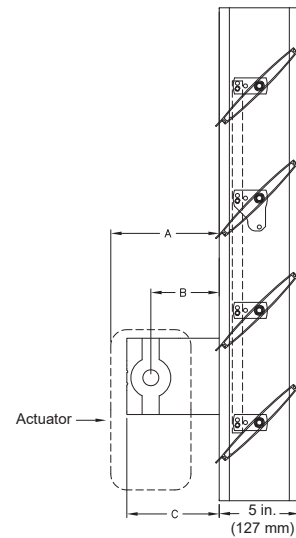

Multi-Section Dampers

Dampers larger than the maximum single section size, will be made up of a multiple of equal size sections.

NOTE: Dampers larger than 60 in. x74 in. (1524mm x 1880mm) are not intended to be structurally self supporting. Refer to IOM document #463384 for structural support requirements on multi-section assemblies.

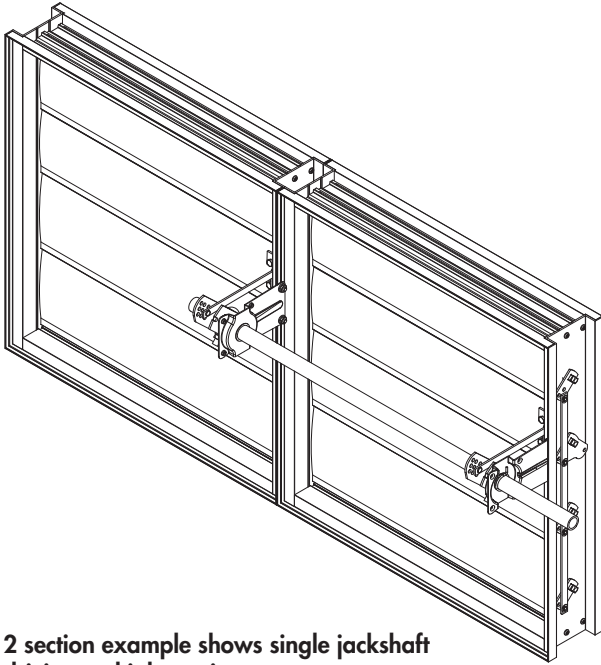

2 section example shows single jackshaft driving multiple sections

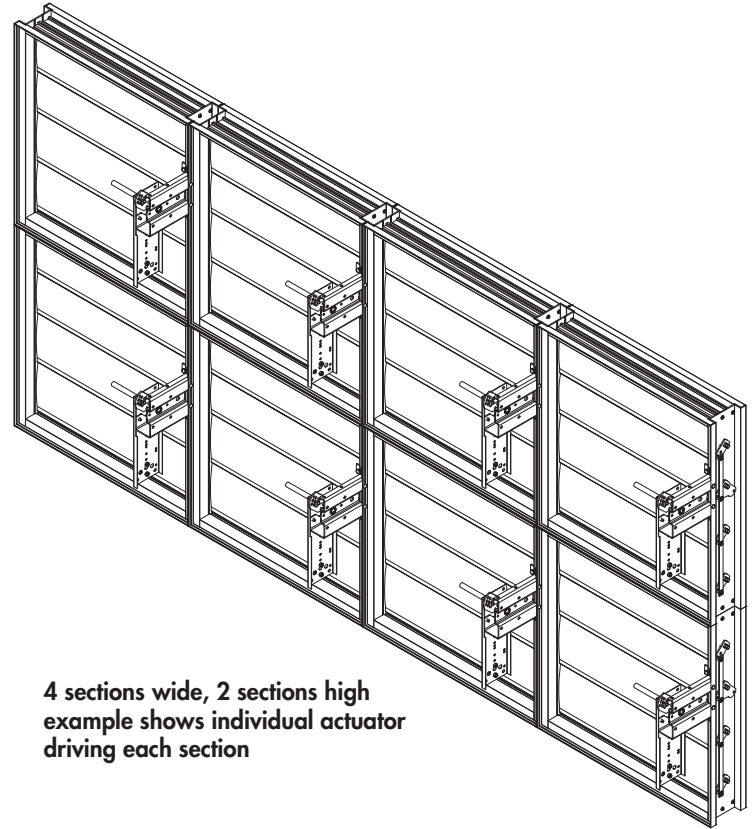

4 sections wide, 2 sections high example shows individual actuator driving each section

Document Links



[INSTALLATION](#)



[CATALOG](#)



[WARRANTY](#)