

### Application

The VCD-43 is a low leakage damper with extruded aluminium airfoil blades and frame. Smooth profile extruded aluminium airfoil blades insure the lowest resistance to airflow in HVAC systems. This model is intended for application in medium to high pressure and velocity systems.

VCD-43 is IECC (International Energy Conservation Code) compliant with a leakage rating of 3 cfm/ft<sup>2</sup> at 1 in. wg (55 cmh/m<sup>2</sup> at .25 kPa) or less.

### Damper Ratings

#### Velocity

Up to 6000 fpm (30.5 m/s)

#### Pressure

Up to 8 in. wg (2 kPa) - pressure differential  
For pressures greater than 8 in. wg, consult factory

#### Leakage

Class 1A at 1 in. wg (0.25 kPa)  
Class 1 up to 4-8 in. wg (1-2 kPa)

#### Temperature

-40°F to 250°F (-40°C to 121°C)

### Construction

	Standard	Optional
<b>Frame Material</b>	Aluminium (6063T5)	-
<b>Frame Material Thickness</b>	.125 in. ( 3.2 mm)	-
<b>Frame Type</b>	5 in. x 1 in. hat channel (127 mm x 25 mm)	Single flange, Reversed flange, Quick connect
<b>Blade Material</b>	Extruded Aluminium (6063T5)	-
<b>Blade Type</b>	Airfoil	-
<b>Blade Action</b>	Opposed	Parallel
<b>Blade Seals</b>	TPE	Silicone
<b>Linkage</b>	Plated steel out of airstream, concealed in jamb	316SS
<b>Axle Bearings</b>	Synthetic (acetal) sleeve	316SS
<b>Axle Material</b>	Plated steel	316SS
<b>Jamb Seal</b>	Stainless Steel	-
<b>Paint Finishes</b>	Mill Finish	Baked Enamel, Hi Pro Polyester, Industrial Epoxy, Kynar/Hylar (70%), Anodize



\*W&H dimension furnished approximately 1/4 in. (6 mm) undersize.

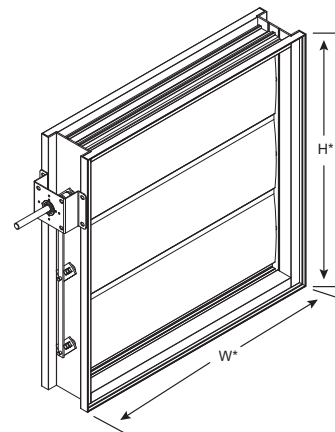

Standard frame shown. See page 3 for more frame options.

### Size Limitations

W x H in. (mm)	Frame Type	
	Channel, Single, or Reverse Flange	Quick Connect
<b>Minimum Sizes*</b>	8 x 6 (203 x 178)	8 x 5 (203 x 127)
<b>Maximum Sizes</b>	<b>Single Section</b>	60 x 78 (1524 x 1981)
	<b>Multiple Section</b>	288 x 234 (7315 x 5944)
		60 x 76 (1524 x 1930)
		144 x 152 (3658 x 3861)

\* varies by actuator

## Note

- Low profile head and sill are used on sizes less than 17 in. high (432mm), excluding quick connect frame.
- Electric actuators and manual operators available. Factory supplied actuators are sized for 1500 fpm (7 m/s) and fully-closed differential pressure of 2 in. wg (.5 kPa). Contact factory for actuator sizing on applications exceeding those limits.
- In applications where airflow could be uneven, such as a discharge fan, it is imperative to verify that at no point the maximum velocity exceeds the damper's cataloged velocity.
- Blades must be horizontal for either horizontal or vertical mount. See VCD-43V model for vertical blade applications.

## Blade Operation

**Parallel blade operation** - this configuration requires the damper blades to rotate in the same direction, parallel to one another.

**Opposed blade operation** - adjacent damper blades rotate opposite one another.

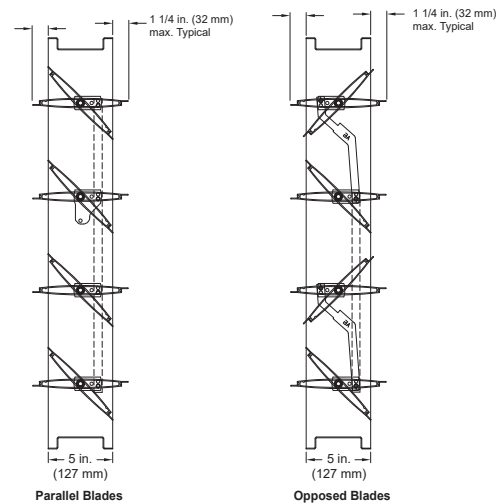

## Options

- Actuators (24V, 120V, manual, pull chain, bracket only)
- Actuator mounting (external, external kit (field assembly), internal)
- NEMA enclosures (3, 4, 4X, 7)
- OCI (open or closed indicator)
- Transformers

# Frame/Flange Options

## Channel Frame

The channel frame option is designed for in-duct or slip-in installation. Dampers with external actuators can be rotated in the field 180 degrees to change from right hand to left hand drive (not recommended on parallel blade dampers).

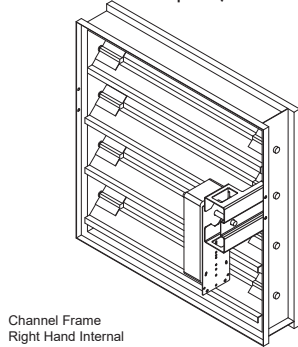

## Reversed Flange

The reversed flange frame option is designed for “flange to wall/ opening” applications. Dampers with external mount actuators must be installed from the interior (cannot be “insert mounted”) to avoid obstructions. Dampers with external actuators can be rotated in the field 180 degrees to change from right hand to left hand drive (not recommended on parallel blade dampers). The flange will be located on the opposite side of the damper frame as the jackshaft/actuator for internal mount actuators.

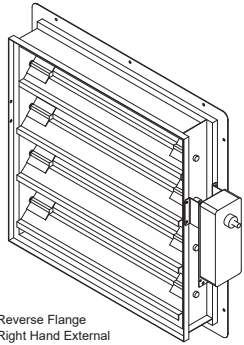

## Single Flange

The single flange frame option is designed for “flange to wall/ opening” applications. Dampers with external mount actuators must be installed from the interior (cannot be “insert mounted”) to avoid obstructions. Dampers with external actuators can be rotated in the field 180 degrees to change from right hand to left hand drive (not recommended on parallel blade dampers). The flange will be located on the same side of the damper frame as the jackshaft/actuator for internal mount actuators.

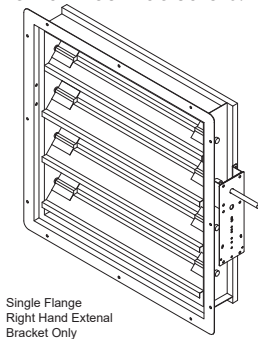

## Quick Connect Frame

The Quick Connect frame type provides flanges on both sides that are compatible with TDC/TDF flange systems commonly used for a “flanged-to-duct” installation. This frame style is available on ICD-44, 45; VCD-43 and VCD-43V.

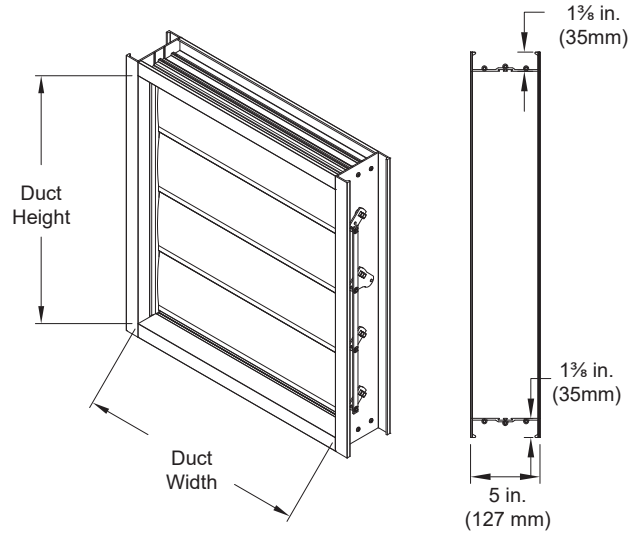

**Note:** When ordering the Quick Connect Frame, size is based on duct size (or inside dimension of the damper frame). Quick connect frame is actual size.

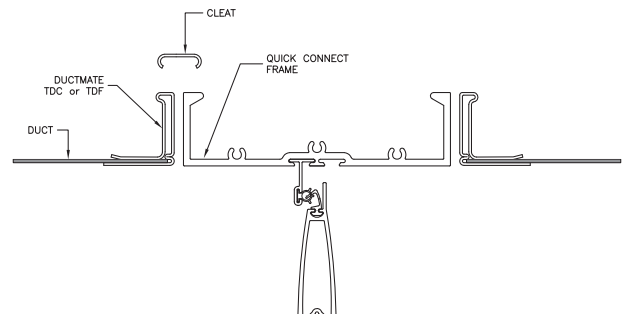

# AMCA Certified Pressure Drop Data

## AMCA 5.2

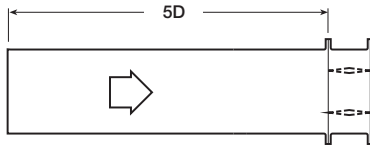

12 in. x 12 in. (305mm x 305mm)

Velocity (fpm)	Pressure Drop (in. wg)
500	0.01
1000	0.06
1500	0.13
2000	0.23
2500	0.35
3000	0.50
3500	0.68
4000	0.88

24 in. x 24 in. (610mm x 610mm)

Velocity (fpm)	Pressure Drop (in. wg)
500	0.01
1000	0.04
1500	0.10
2000	0.18
2500	0.28
3000	0.40
3500	0.54
4000	0.70

36 in. x 36 in. (914mm x 914mm)

Velocity (fpm)	Pressure Drop (in. wg)
500	0.01
1000	0.03
1500	0.06
2000	0.12
2500	0.18
3000	0.26
3500	0.35
4000	0.46

12 in. x 48 in. (305mm x 1219mm)

Velocity (fpm)	Pressure Drop (in. wg)
500	0.01
1000	0.06
1500	0.13
2000	0.23
2500	0.36
3000	0.51
3500	0.71
4000	0.93

48 in. x 12 in. (1219mm x 305mm)

Velocity (fpm)	Pressure Drop (in. wg)
500	0.01
1000	0.03
1500	0.06
2000	0.10
2500	0.16
3000	0.23
3500	0.30
4000	0.39

## AMCA 5.3

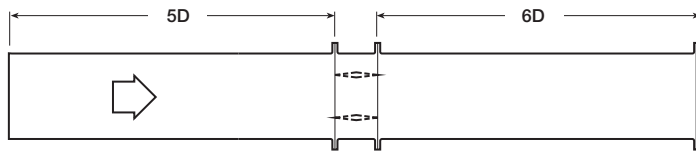

12 in. x 12 in. (305mm x 305mm)

Velocity (fpm)	Pressure Drop (in. wg)
500	0.01
1000	0.03
1500	0.07
2000	0.14
2500	0.21
3000	0.29
3500	0.39
4000	0.51

24 in. x 24 in. (610mm x 610mm)

Velocity (fpm)	Pressure Drop (in. wg)
500	0.01
1000	0.02
1500	0.04
2000	0.08
2500	0.13
3000	0.19
3500	0.26
4000	0.34

36 in. x 36 in. (914mm x 914mm)

Velocity (fpm)	Pressure Drop (in. wg)
500	0.01
1000	0.01
1500	0.02
2000	0.04
2500	0.06
3000	0.09
3500	0.13
4000	0.17

12 in. x 48 in. (305mm x 1219mm)

Velocity (fpm)	Pressure Drop (in. wg)
500	0.01
1000	0.03
1500	0.06
2000	0.11
2500	0.17
3000	0.25
3500	0.34
4000	0.45

48 in. x 12 in. (1219mm x 305mm)

Velocity (fpm)	Pressure Drop (in. wg)
500	0.01
1000	0.02
1500	0.04
2000	0.08
2500	0.12
3000	0.18
3500	0.24
4000	0.31

## AMCA 5.5

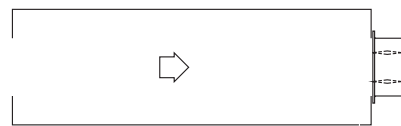

12 in. x 12 in. (305mm x 305mm)

Velocity (fpm)	Pressure Drop (in. wg)
500	0.04
1000	0.14
1500	0.31
2000	0.55
2500	0.86
3000	1.23
3500	1.67
4000	2.19

24 in. x 24 in. (610mm x 610mm)

Velocity (fpm)	Pressure Drop (in. wg)
500	0.03
1000	0.12
1500	0.27
2000	0.48
2500	0.75
3000	1.07
3500	1.47
4000	1.91

36 in. x 36 in. (914mm x 914mm)

Velocity (fpm)	Pressure Drop (in. wg)
500	0.03
1000	0.10
1500	0.22
2000	0.39
2500	0.61
3000	0.87
3500	1.19
4000	1.56

12 in. x 48 in. (305mm x 1219mm)

Velocity (fpm)	Pressure Drop (in. wg)
500	0.03
1000	0.11
1500	0.25
2000	0.46
2500	0.72
3000	1.05
3500	1.43
4000	1.87

48 in. x 12 in. (1219mm x 305mm)

Velocity (fpm)	Pressure Drop (in. wg)
500	0.03
1000	0.11
1500	0.26
2000	0.46
2500	0.72
3000	1.02
3500	1.40
4000	1.83

## Leakage

Air leakage is based on operation between 32°F (0°C) and 120°F (49°C).

Tested for leakage in accordance with ANSI/AMCA Standard 500-D, Figure 5.5.

Tested for air performance in accordance with ANSI/AMCA Standard 500-D, Figures 5.2, 5.3 and 5.5.

### Torque

Data are based on a torque of 5.0 in. lb./ft<sup>2</sup> (0.56 N·m) applied to close and seat the damper during the test.

VCD-43	Leakage Class*		
Maximum Damper Width	1 in. wg (0.25 kPa)	4 in. wg (1 kPa)	8 in. wg (2 kPa)
60 in. (1524mm)	1A	1	1
* applies to opposed blades only			

### \*Leakage Class Definitions

The maximum allowable leakage is defined as the following:

- Leakage Class 1A - 3 cfm/ft<sup>2</sup> at 1 in. wg (class 1A is only defined at 1 in. wg).
- Leakage Class 1
  - 4 cfm/ft<sup>2</sup> at 1 in. wg
  - 8 cfm/ft<sup>2</sup> at 4 in. wg
  - 11 cfm/ft<sup>2</sup> at 8 in. wg
  - 12.6 cfm/ft<sup>2</sup> at 10 in. wg

## Velocity and Temperature Limitations

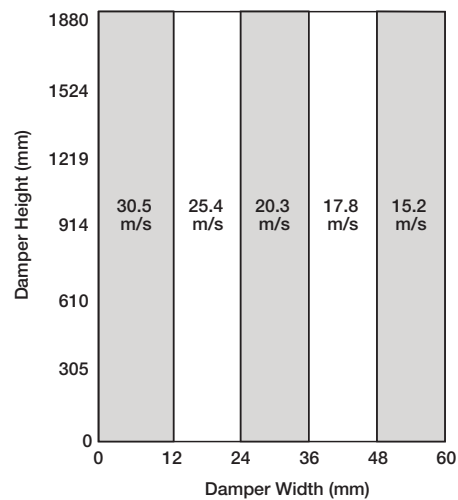
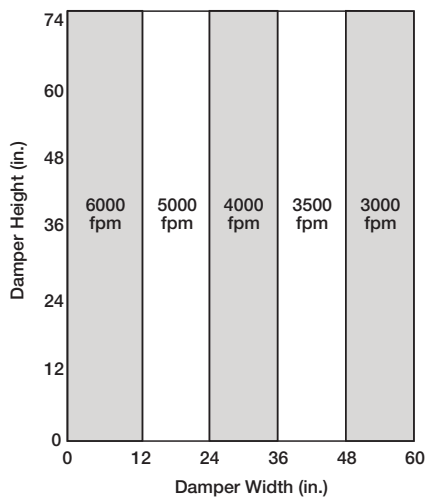

## Temperature Limitations

Blade Seal	Temperature Range
TPE	-10°F to 200°F (-23°C to 93°C)
Silicone	-40°F to 250°F (-40°C to 121°C)

## Space Envelopes

Externally mounted actuators always require space outside the damper. The "D" dimension illustrates the clearance required for various available actuators. Dampers less than 18 in. (457mm) high may require actuator clearances above and/or below the damper frame. "B" and "T" dimensions are worst case clearance requirements for some dampers less than 18 in. (457mm) high. All damper sizes under 18 in. (457mm) high do not require these worst case clearances. If space availability above or below the damper is limited, each damper size should be individually evaluated.

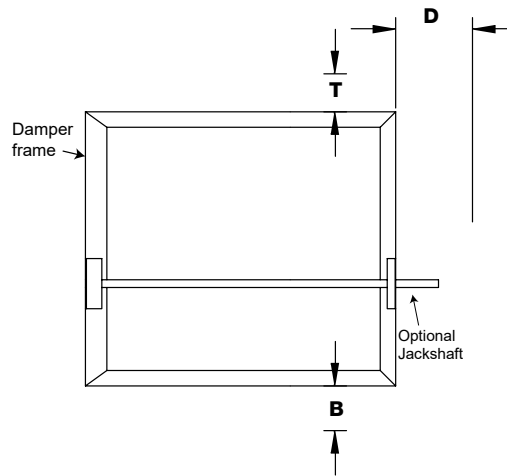

Actuator Type/Model	Height	T	B	D
	Inches		Inches	
AFBUP (-S) and FSNF Series, Belimo MSxx20 Series, Honeywell	≥6 to <10	0	12¾	6¼
	≥10 to <18	0	2	6¼
	≥18	0	0	6¼
FSLF, LF and TFB Series, Belimo	≥6 to <10	0	3½	6¼
	≥10	0	0	6¼
MSxx04 & MSxx09 Series, Honeywell	≥6 to <9	0	4¾	6¼
	≥9	0	0	6¼
MS75xx Series, Honeywell	≥6 to <10	0	12¾	6¼
	≥10 to <18	0	7	6¼
	≥18	0	0	6¼
GRD and GVD Series, Siemens	≥6 to <10	0	12¾	6¼
	≥10 to <18	0	2	6¼
	≥18	0	0	6¼
GJD Series, Siemens	≥6 to <10	0	3½	6¼
	≥10 to <18	0	0	6¼
	≥18	0	0	6¼

## Actuator Mounting

Actuators may be installed at the factory, shipped loose with the necessary linkage and brackets for mounting, or field supplied. For more detail information on actuator mounting, click on link below or scan QR code.



[ACTUATOR MOUNTING](#)

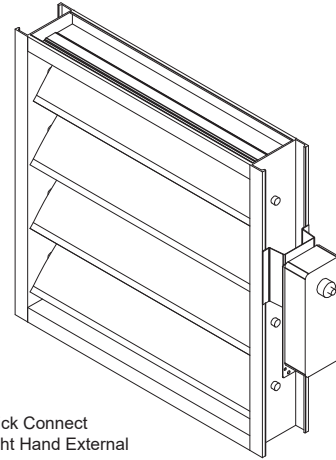

Quick Connect  
Right Hand External

## Clearance Requirements

This drawing depicts the worst case clearance requirements for an actuator with a jackshaft.

Internal mount only Actuator model	A	B	C
All except - EFB & EFCX Series	7 in (178 mm)	3 ¾ in (95 mm)	6 ¾ in (171 mm)
EFB & EFCX Series	9 in (229 mm)	6 in (152 mm)	9 in (229 mm)

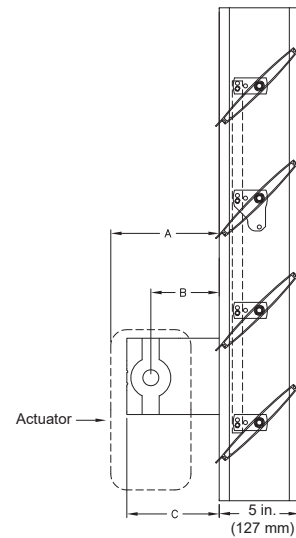

## Multi-Section Dampers

Dampers larger than the maximum single section size, will be made up of a multiple of equal size sections.

**NOTE:** Dampers larger than 60 in. x74 in. (1524mm x 1880mm) are not intended to be structurally self supporting. Refer to IOM document #463384 for structural support requirements on multi-section assemblies.

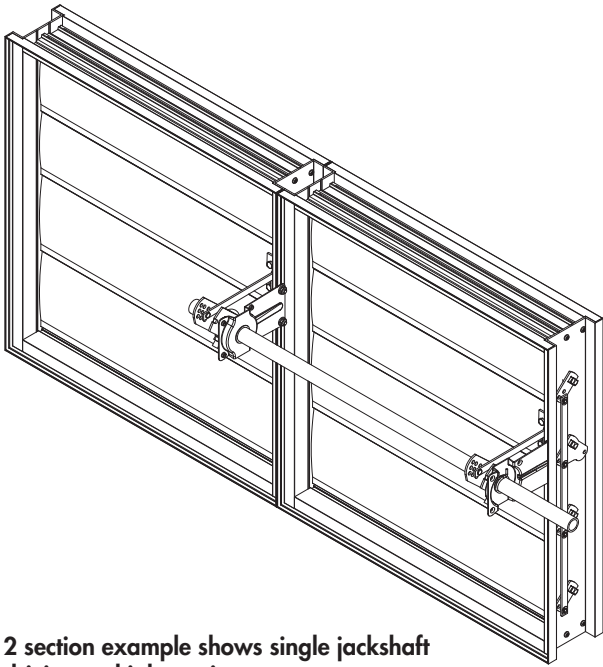

2 section example shows single jackshaft driving multiple sections

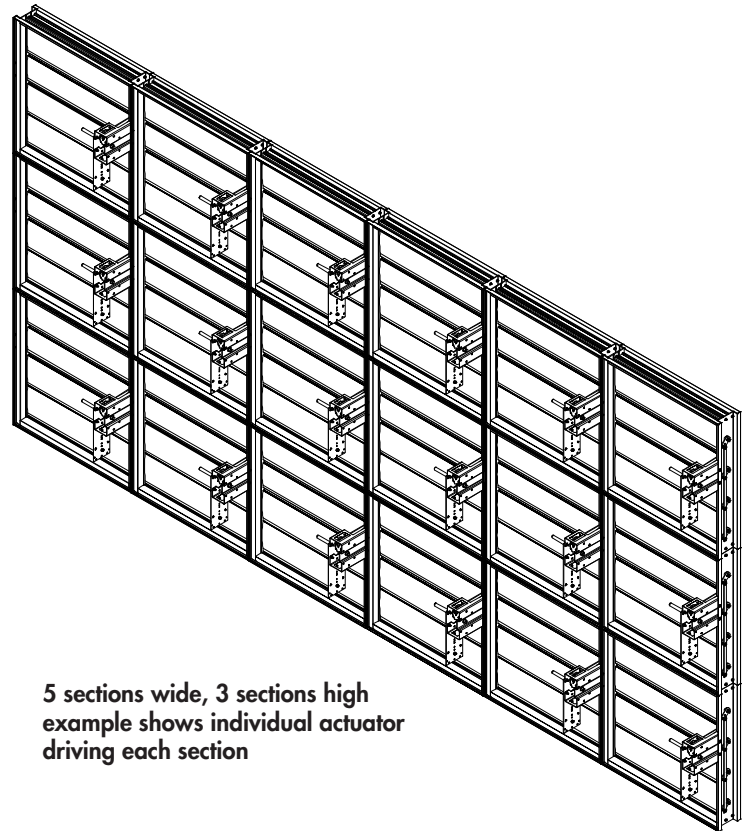

5 sections wide, 3 sections high example shows individual actuator driving each section

## Document Links



[INSTALLATION](#)



[CATALOG](#)



[SELECTION GUIDE](#)



[WARRANTY](#)